

—
OPTIONS FOR ABB DRIVES

FPNO-21 PROFINET fieldbus adapter module

User's manual

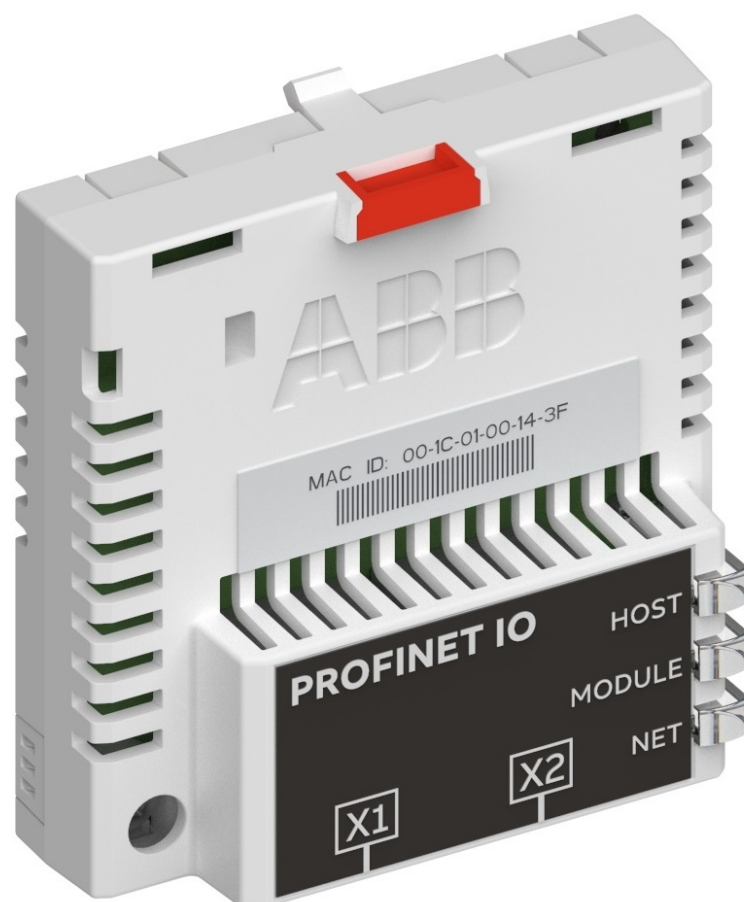

FPNO-21 PROFINET fieldbus adapter module

User's manual

Table of contents



1. Safety instructions



4. Mechanical installation



5. Electrical installation



Table of contents

1 Safety instructions

Contents of this chapter	11
Use of warnings and notes	11
Safety in installation and maintenance	12

2 Introduction to the manual

Contents of this chapter	13
Applicability	13
Compatibility	13
Drives	13
Protocol	14
Target audience	14
Purpose of the manual	14
Cyber security disclaimer	14
Terms and abbreviations	15
Related documents	17

3 Overview of the Ethernet network and the FPNO-21 module

Contents of this chapter	19
Ethernet network	19
Example topology of the Ethernet link	19
FPNO-21 module overview	21
FPNO-21 module layout	22

4 Mechanical installation

Contents of this chapter	23
Necessary tools and instructions	23
Unpacking and examining the delivery	23
Before you start	23
Installing option modules	24

5 Electrical installation

Contents of this chapter	25
Necessary tools and instructions	25
General cabling instructions	25
Connecting the FPNO-21 module to the network	25

6 PROFINET IO – Start-up

Contents of this chapter	27
Warnings	27
Drive configuration	27
PROFINET IO connection configuration	27
FPNO-21 configuration parameters – group A (group 1)	28
FPNO-21 configuration parameters – group B (group 2)	36



FPNO-21 configuration parameters – group C (group 3)	37
Emulation modes	38
Control locations	38
Starting up fieldbus communication for drives	39
Parameter setting examples – ACS380, ACS480, ACH580, ACQ580, and ACS580 ...	40
Frequency control using PROFIdrive communication profile with PPO Type 4 ...	40
Parameter setting examples – ACS880	41
Speed control using PROFIdrive communication profile with PPO Type 4	41
Configuring the master station	43
Downloading the GSD file	43
Configuring an ABB AC500 PLC	43
Configuring a Siemens SIMATIC S7 PLC	47
Resetting PROFINET IO device to factory default via S7	52
Configuring a Siemens PLC with TIA14	56
Media Redundancy Protocol (MRP)	65
Configuring Media Redundancy Protocol (MRP) with Siemens PLC	65
Configuring Media Redundancy Protocol (MRP) with TIA14	71
Shared Device	74
Configuring Shared Device for ABB PLC with Automation Builder	74
Configuring the drive control PLC	74
Configuring the safety PLC	75
Configuring Shared Device for Siemens PLC with TIA portal	77
Configuring the drive control PLC	77
Configuring the safety PLC	77
S2 system redundancy	78

7 PROFINET IO – Communication profiles

Contents of this chapter	79
Communication profiles	79
PROFIdrive communication profile	80
Control word and Status word	80
Control word contents	81
Status word contents	82
State machine for all operating modes	85
State machine for the positioning mode	86
References	87
References in speed control mode	87
Actual values	87
Actual values in speed control mode	87
ABB Drives communication profile	87
Control word and Status word	87
Control word contents	87
Status word contents	89
State machine	91
References	91
Scaling	92
Actual values	93
Scaling	93
PROFIdrive v4.2 communication profile	93
Supported drives	93
Control word and Status word	93
Control word contents	93

Status word contents	95
State machine	96
References	98
References in speed control mode	98
Actual values	98
Actual values in speed control mode	98
8 PROFINET IO – Communication protocol	
Contents of this chapter	99
PROFINET IO	99
PROFINET network settings	100
PROFINET IO in FPNO-21	100
The services provided by the FPNO-21 module	101
Cyclic message types	101
PPO types	101
Standard telegram (ST) types (DP-V1)	102
Behavior of output data	103
Parameter handling using acyclic parameter access mechanism (DP-V1)	103
Header and frame structures	103
ErrorCode1	104
DP-V1 read/write request sequence	104
Read and write blocks	105
Data block	106
Function blocks for sending DP-V1 messages (Siemens S7)	110
Parameter data transfer examples	110
Example 1a: Reading a drive parameter (array element)	111
Example 1b: Reading 3 drive parameters (multi-parameter)	112
Example 2a: Writing a drive parameter (one array element)	114
Example 2b: Writing 2 drive parameters (multi-parameter)	115
Example 3: Reading a PROFIdrive parameter	117
Example 4: Configuring the process data written to the drive	117
Example 5: Determining the source of the process data read from the drive	119
Example 6: Reading one element from the parameter description	120
Diagnostic and alarm mechanism	121
Alarm mechanism	121
Fault code mapping	121
Fault buffer mechanism	122
9 PROFINET IO – Diagnostics	
Contents of this chapter	125
Fault and warning messages	125
LEDs	125
10 NONE – Start-up	
Contents of this chapter	127
Warnings	127
Drive configuration	127
Connection configuration for the NONE protocol	127
FPNO-21 configuration parameters – group A (group 1)	128
Starting up fieldbus communication	134



11 NONE – Diagnostics

Contents of this chapter135
 Fault and warning messages135
 LEDs135

12 Technical data

Contents of this chapter137
 Dimension drawing137
 General data138
 Ethernet link138
 TCP and UDP service ports139

13 Appendix A – PROFIdrive parameters and I&M records of PROFINET IO

Contents of this chapter141
 PROFIdrive parameters141
 PROFIdrive parameter descriptions147
 I&M records148
 Call-REQ-PDU telegram for read/write access to I&M records148
 Response structure for I&M0 (Read-only)149
 Response structure for I&M1 (Read/Write)149
 Response structure for I&M2 (Read/Write)149
 Response structure for I&M3 (Read/Write)149
 Response structure for I&M4 (Read/Write)150
 Drive information150

14 Appendix B – ABB IP configuration tool

Contents of this chapter151
 Installation151
 Finding adapter modules in the network151
 Rewriting the IP configuration of adapter modules152

15 Appendix C - FPNO-21 configuration web pages

Contents of this chapter155
 Browser requirements155
 Compatibility155
 Logging in155
 Menu overview157
 Status page157
 Configuration page157
 Changing the PROFINET IO station name via web page160
 Service configuration page161
 Configuring SNTP162
 Security page163
 Support page164
 Password page165
 Firmware update page166
 Reset FPNO-21 web page password to default167
 Enable web page access if it is disabled167



16 Appendix D - FPNO-21 configuration back-up

Contents of this chapter	169
Compatibility	169
Settings for backup	169
Configuration backup for all protocols in FPNO-21	169
Using the restored backup	170

17 Appendix E - OPC UA server

Contents of this chapter	173
OPC UA	173
Compatibility	174
Supported services and features	174
Enabling OPC UA server on an ABB drive	175
Encrypted Communication	175
OPC UA subscription	176
Accessing drive events and event log with OPC UA	177
Connection example	178
Technical data	182

Further information

1

Safety instructions



Contents of this chapter

The chapter describes the warning symbols used in this manual and refers to the safety instructions which you must obey when you install or connect an option module. If you ignore the safety instructions, injury, death or damage can occur. Read this chapter before you start the installation.

Use of warnings and notes

Warnings tell you about conditions which can cause injury or death, or damage to the equipment. They also tell you how to prevent the danger. Notes show a particular condition or fact, or give information.

The manual uses these warning symbols:

**WARNING!**

Electricity warning tells about hazards from electricity which can cause injury or death, or damage to the equipment.

**WARNING!**

General warning tells about conditions other than those caused by electricity, which can cause injury or death, or damage to the equipment.

**WARNING!**

Electrostatic sensitive devices warning tells you about the risk of electrostatic discharge which can cause damage to the equipment.

Safety in installation and maintenance



WARNING!

Obey the safety instructions of the drive. If you ignore them, injury or death, or damage to the equipment can occur. If you are not a qualified electrical professional, do not do installation, commissioning or maintenance work.





Introduction to the manual

Contents of this chapter

This chapter introduces this manual.

Applicability

This manual applies to the FPNO-21 PROFINET fieldbus adapter module (referred to as FPNO-21 module from here on), adapter revision N or firmware version 2.03 or later.

Compatibility

■ Drives

The FPNO-21 module is compatible with:

- ACS880 primary control program version 2.51.0.0 and later
- ACS580 standard control program version 2.02.0.1 and later
- ACH580 HVAC control program 2.01.0.4 and later
- ACQ580 pump control program 2.03.0.3 and later
- ACS355 drives firmware version 5.090 and later
- ACS380 machinery control program version 2.02.0.1 and later
- ACS480 standard control program 2.02.0.3 and later
- ACS560 standard control program 2.08.0.0 and later

Note: Not all compatible drives are listed here. For information on compatibility, refer to the drive firmware manual. You can see the current firmware version of the drive from parameter 07.05 Firmware version.

■ Protocol

The FPNO-21 module is compatible with Ethernet standards IEEE 802.3 and IEE 802.3u and it supports the PROFINET IO protocol.

All PROFINET IO masters that support:

- GSDML file version 2.4
- PROFINET IO protocol according to IEC standards 61158 and 61784
- PROFINET IO conformance class B

are compatible with the PROFINET IO module.

The FPNO-21 module can run other protocols. You can enable and disable these protocols via web pages:

- ABB IP configuration tool
- Simple Network Time Protocol (SNTP)
- HTTPS for web page
- Open Platform Communications Unified Architecture (OPC UA)
- Drive composer tool via Ethernet tool network.

The FPNO-21 module can also run the NONE protocol which is the no communication protocol. In this setup, the FPNO-21 module is used to run only Ethernet services. When the PROFINET protocol is not required, select the NONE protocol.

Target audience

This manual is intended for people who plan the installation, install, start up, use and service the module. Before you do work on the module, read this manual and the applicable drive manual that contains the hardware and safety information for the product. You are expected to know the fundamentals of electricity, wiring, electrical components, and electrical schematic symbols.

Purpose of the manual

The manual provides information on how to install, commission and use the FPNO-21 module.

Cyber security disclaimer

This product is designed to be connected to and to communicate information and data via a network interface. It is Customer's sole responsibility to provide and continuously ensure a secure connection between the product and Customer network or any other network (as the case may be). Customer shall establish and maintain any appropriate measures (such as but not limited to the installation of firewalls, application of authentication measures, encryption of data, installation of anti-virus programs, etc.) to protect the product, the network, its system and the interface against any kind of security breaches, unauthorized access, interference, intrusion, leakage and/or theft of data or information.

ABB and its affiliates are not liable for damages and/or losses related to such security breaches, any unauthorized access, interference, intrusion, leakage and/or theft of data or information.

Terms and abbreviations

Term	Description
ACT	Actual value <i>Istwert</i>
Acyclic communication	Communication in which messages are sent only once on request
Array	Parameter consisting of data fields of equal data type
Command word	See Control word.
Control word	16-bit or 32-bit word from a controller to the controlled device with bit-coded control signals (sometimes called the Command word).
Cyclic communication	Communication in which messages are sent cyclically at pre-defined intervals
DAP	Device access point
Data object	Special object that contains parameter and process data
DCP	Discovery Control Protocol. A protocol that allows the master controller to find every PROFINET IO device on a subnet.
DHCP	Dynamic Host Control Protocol. A protocol for automating the configuration of IP devices. DHCP can be used to automatically assign IP addresses and related network information.
DP	Decentralized Periphery <i>Dezentrale Peripherie</i>
DP-V0	PROFINET IO extension to the EN 50170 standard, providing the basic functionality of DP, including cyclic data exchange
DP-V1	PROFINET IO extension to the EN 50170 standard, including, eg, acyclic data exchange
Drive	Frequency converter for controlling AC motors
EMC	Electromagnetic compatibility
Fault	Event that leads to tripping of the device
FBA	Fieldbus adapter
Fieldbus adapter module	Device through which the drive is connected to an external communication network, that is, a fieldbus
GSD file	General Station Description file, an ASCII-format device description file in a specified form. Each different slave type on the PROFINET IO network needs to have its own GSD file. GSD files in PROFINET IO are written in GSDML.
GSDML	General Station Description Markup Language
I/O controller	Control system with bus initiative. In PROFINET IO terminology, I/O controllers are also called master stations.
Index	Access reference for objects in PROFINET IO
ISW	See ACT.
LSB	Least significant bit
MAC address	Media Access Control address
MAP	Module access point
Master	Control system with bus initiative. In PROFINET IO terminology, master stations are also called active stations.
MSB	Most significant bit
OPC UA	Open Platform Communications Unified Architecture
PAP	Parameter access point
Parameter	In the drive control program, user-adjustable operation instruction to the drive, or signal measured or calculated by the drive. In some (for example fieldbus) contexts, a value that can be accessed as an object. For example, variable, constant, or signal.
Parameter/Process data object	Special object that contains parameter and process data
PD	Process data <i>Prozessdaten</i>

16 Introduction to the manual

Term	Description
PKE	Parameter identification <i>Parameter-Kennung</i>
PKW	Parameter identification value <i>Parameter-Kennung-Wert</i>
PLC	Programmable logic controller
PNU	Parameter number <i>Parameternummer</i>
PPO	Parameter/Process data object <i>Parameter-/Prozessdaten-Objekt</i>
Process data	Data that contains a Control word and reference value or a Status word and actual value. May also contain other (user-definable) control information.
Profile	Adaptation of a communication protocol for a certain application field (for example, drives)
PROFINET S2	PROFINET S2 system redundancy device has one Network Access Point (NAP) interface which supports two redundant connections from two redundant controllers.
PWE	Parameter value <i>Parameter-Wert</i>
PZD	PD, Process data
PZDO	Process data object <i>Prozessdatenobjekt</i>
SAP	Service access point
Slave	Passive bus participant. In PROFINET IO terminology, slave stations (or slaves) are also called passive stations. Also referred to as a node.
SNTP	Simple Network Time Protocol. A protocol to synchronize drive time with the network time server.
SOW	Reference <i>Sollwert</i>
Status word	16-bit or 32-bit word from a controlled device to the controller with bit-coded status signals
STW	Control word <i>Steuerwort</i>
Warning	Signal caused by an existing alarm which does not lead to tripping of the device
ZSW	Status word <i>Zustandswort</i>

Related documents

Manual	Code
Drive hardware manuals and guides	
ACS380-04 manuals	9AAK10103A6193
ACS480 manuals	9AKK106930A8739
ACS580-01 manuals	9AKK105713A8085
ACH580-01 manuals	9AKK10103A0587
ACQ580-01 manuals	9AKK106713A2709
ACS580-04 manuals	9AKK106930A9060
ACH580-04 manuals	9AKK106930A9059
ACQ580-04 manuals	9AKK106930A9053
ACS580-07 manuals	9AKK106930A5239
ACH580-07 manuals	9AKK106930A5241
ACQ580-07 manuals	9AKK106930A3150
ACS880-01 manuals	9AKK105408A7004
ACS880-04 manuals	9AKK105713A4819
ACS880-07 (45 to 710 kW) manuals	9AKK105408A8149
ACS880-07 (560 to 2800 kW) manuals	9AKK105713A6663
ACS880-07LC manuals	9AKK107680A9275
ACS880-11 manuals	9AKK106930A9565
ACS880-14 manuals	9AKK107045A8023
ACS880-17 (45 to 400 kW) manuals	9AKK106930A3466
ACS880-17 (160 to 3200 kW) manuals	9AKK106354A1499
ACS880-17LC manuals	9AKK107492A4721
ACS880-31 manuals	9AKK106930A9564
ACS880-34 manuals	9AKK107045A8025
ACS880-37 (45 to 400 kW) manuals	9AKK106930A3467
ACS880-37 (160 to 3200 kW) manuals	9AKK106354A1500
ACS880-37LC manuals	9AKK107492A4722
ACS880 multidrive manuals	9AKK106103A9122
ACS880 multidrive module manuals	9AKK105713A3673
Option manuals and guides	
FPNO-21 PROFINET fieldbus adapter module user's manual	3AXD50000158614
FPNO-21 PROFINET adapter module quick guide	3AXD50000158577

The links above contain lists of documents.

You can find manuals on the Internet. See below for the relevant code/link. For more documentation, go to www.abb.com/drives/documents.

For manuals not available in ABB Library, contact your local ABB representative.

18 Introduction to the manual



FPNO-21 PROFINET fieldbus adapter module
User's manual



Fieldbus connectivity web page

3

Overview of the Ethernet network and the FPNO-21 module

Contents of this chapter

This chapter contains a short description of the Ethernet network and the topology supported by the FPNO-21 module.

Ethernet network

Ethernet standards support a variety of physical media (coaxial cable, twisted pair, fiber optics) and topologies (bus and star).

The FPNO-21 module supports:

- twisted pair as the physical media
- star topology, daisy chain topology and ring topology ([Media Redundancy Protocol \(MRP\) \(page 65\)](#))
- PROFINET S2 system redundancy with two redundant controllers.

The maximum length for an Ethernet segment on twisted pair media is 100 m (328 ft). All twisted pair media between the Ethernet node and the switch or router must be shorter than 100 m (328 ft), including media within patch panels.

■ Example topology of the Ethernet link

The figures below show example topologies for an Ethernet network with FPNO-21 module.

20 Overview of the Ethernet network and the FPNO-21 module

Star topology

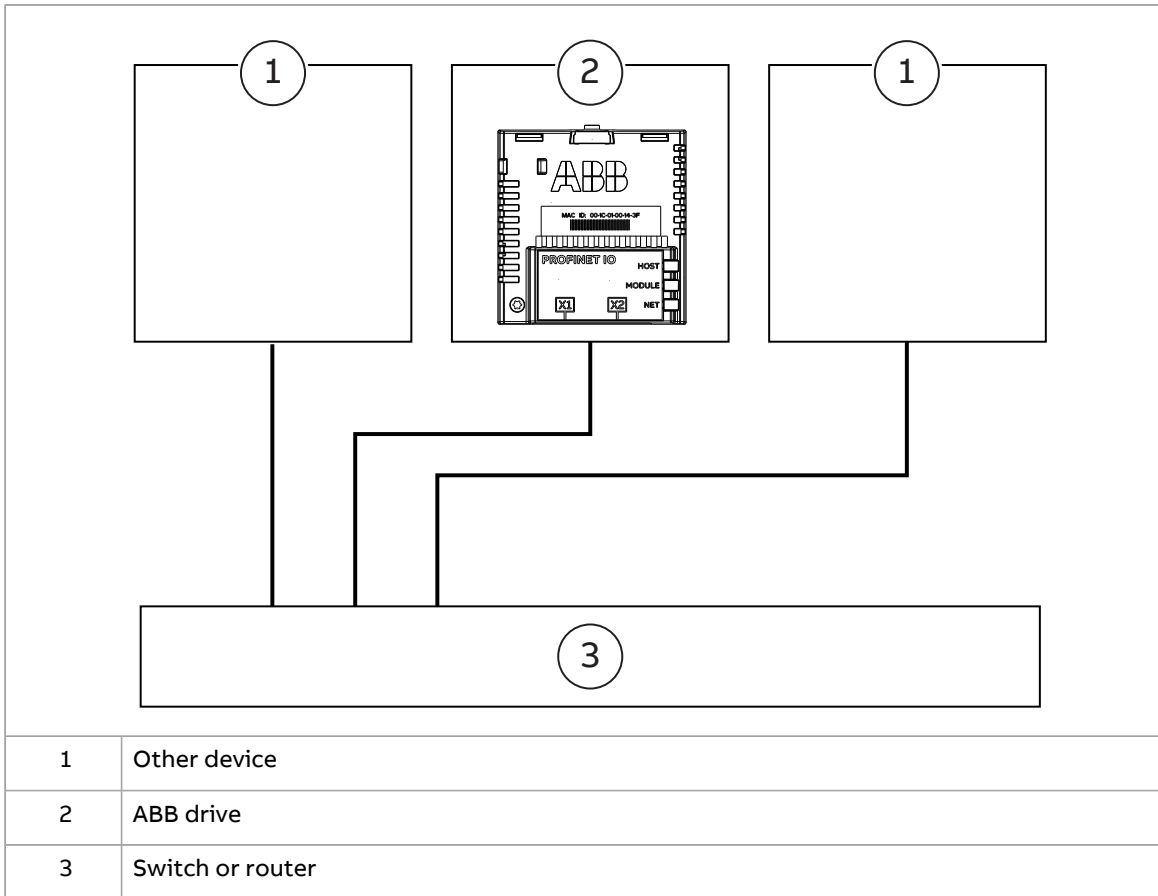

Daisy chain topology

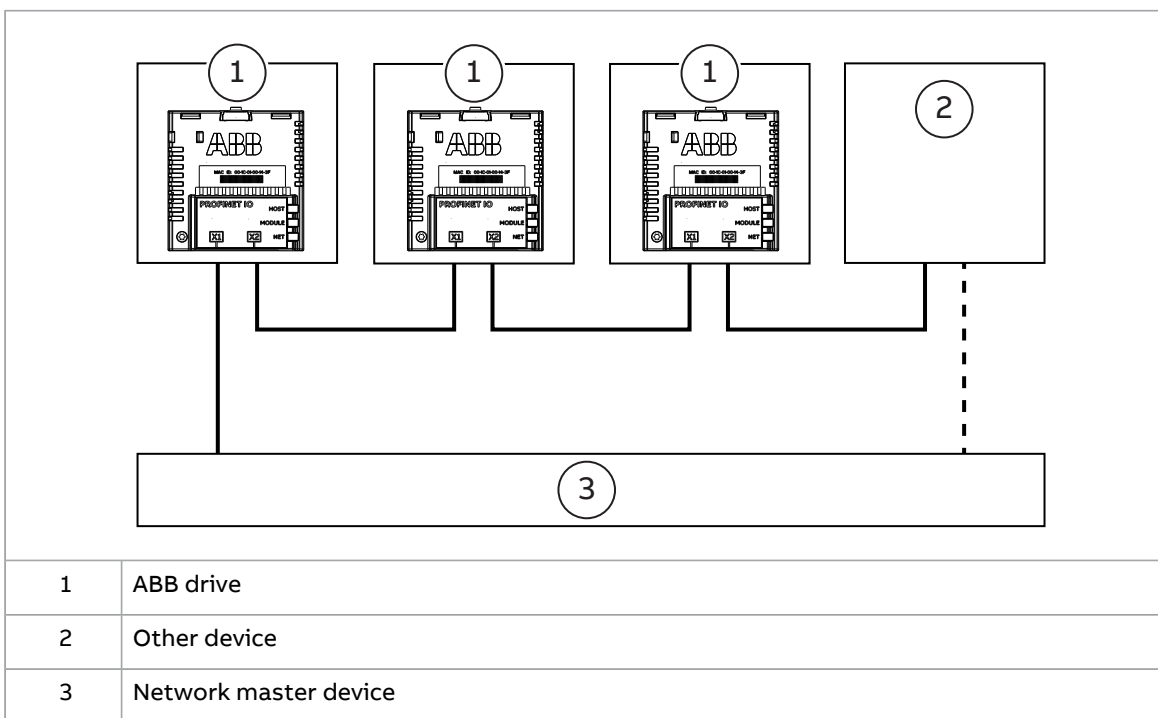

Ring (MRP) topology

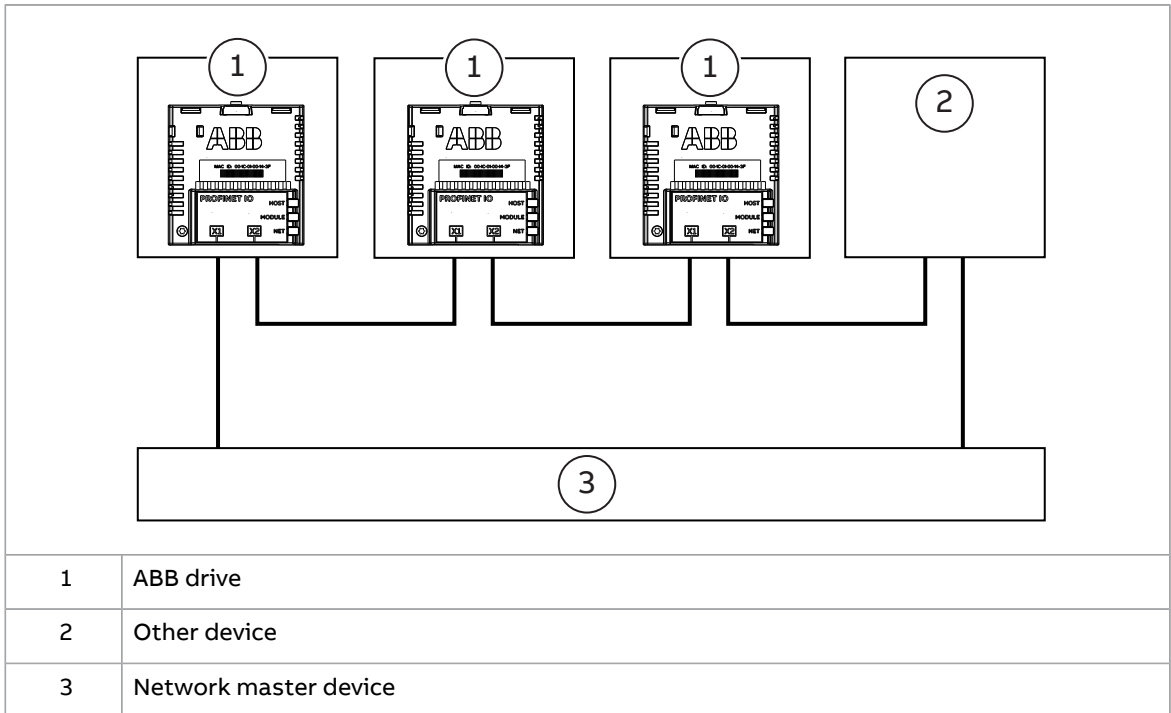

Ring topology with two redundant controllers

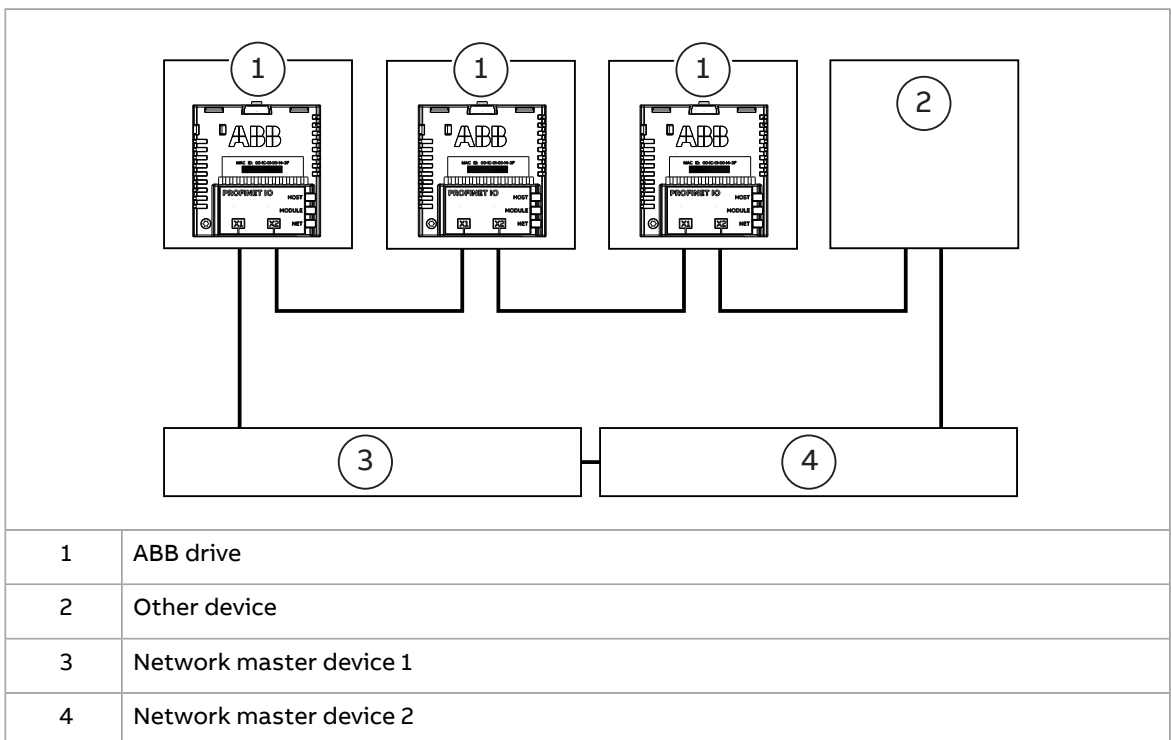

FPNO-21 module overview

The FPNO-21 adapter module is a plug-in device for ABB drives which enables the connection of the drive to a PROFINET IO network.

Through the FPNO-21 module you can:

- give control commands to the drive (for example, Start, Stop, Run enable)
- feed a motor speed or torque reference to the drive
- give a process actual value or a process reference to the PID controller of the drive
- read status information and actual values from the drive
- reset a drive fault
- read/write parameters of the drive
- synchronize the real time clock
- connect to the drive via OPC UA client for monitoring and diagnostics of the drive
- connect a PC with the Drive Composer pro tool.

The adapter module supports 10 Mbit/s and 100 Mbit/s data transfer rates and automatically detects the data transfer rate of the network.

Note: PROFINET IO uses only 100 Mbit/s in the full-duplex mode.

The FPNO-21 module is installed into an option slot on the drive control unit. Refer to the drive manuals for module placement options.

■ FPNO-21 module layout

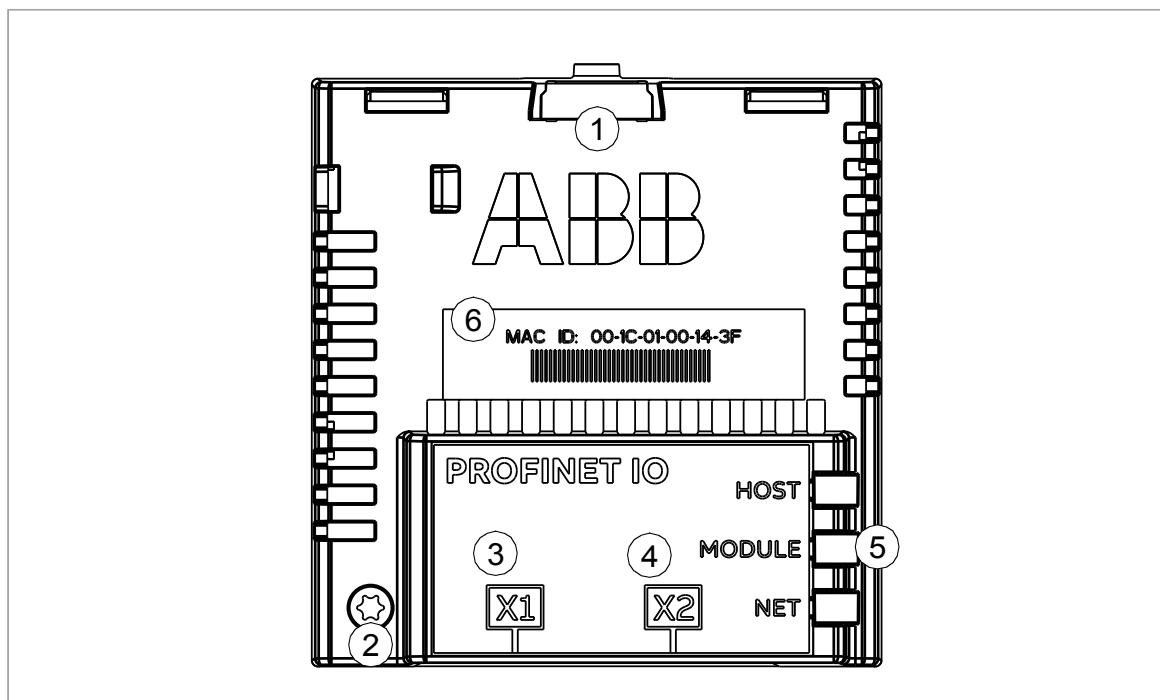

1	Lock
2	Mounting screw (Grounding screw)
3	X1 connector to Ethernet (RJ-45)
4	X2 connector to connect to another module in the chain (RJ-45)
5	Diagnostic LEDs
6	MAC address

4

Mechanical installation

Contents of this chapter

This chapter contains a delivery checklist and instructions on installing the module.

Necessary tools and instructions

Use a Torx TX10 screwdriver to attach the FPNO-21 module to the drive. For more information, refer to the drive hardware manual.

Unpacking and examining the delivery

1. Open the option package.
2. Make sure that the package contains:
 - fieldbus module, type FPNO-21
 - quick guide.
3. Make sure that there are no signs of damage.

Before you start

Install the FPNO-21 module in a free option slot on the drive control unit. Plastic pins, a lock and one screw hold the module in place. The screw also makes an electrical connection between the FPNO-21 module and drive frame for cable shield grounding.

Do not install the FPNO-21 module on the FEA-03 F-series extension adapter.

When you install the FPNO-21 module, it makes the signal and power connection to the drive through a 20-pin connector.



Installing option modules



WARNING!

Obey the safety instructions of the drive. If you ignore them, injury or death, or damage to the equipment can occur.

Pay attention to the free space required by the cabling and terminals that connect to the option modules.

1. Stop the drive and do the steps in section **Electrical safety precautions** of the drive hardware manual.
2. Get access to the drive control unit. For the location of the control unit, refer to the drive hardware manual.
3. Pull out the lock on the module (a).
4. Install the module in a free option module slot on the control unit.
5. Push in the lock on the module (a).
6. Torque the grounding screw (b) to 0.8 N·m (7 lbf·in).

Note: The screw tightens the connections and grounds the module. It is necessary for fulfilling the EMC requirements and for correct operation of the module.



WARNING!

Do not use excessive force, or leave the screw too loose. Over-tightening can cause damage to the screw or module. A loose screw can cause an operation failure.

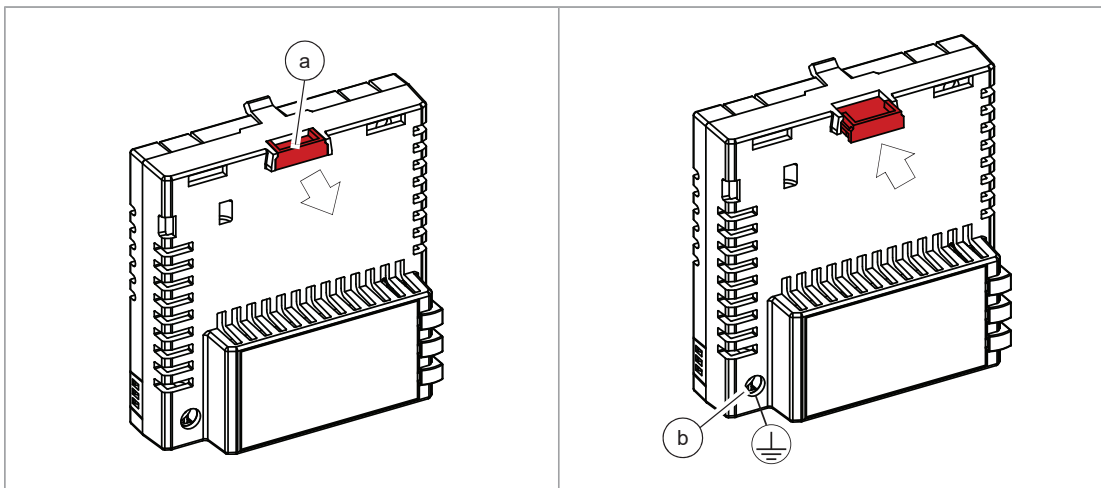

7. Connect the wiring to the module. Obey the instructions in this manual.

If you must remove the adapter module after it was installed into the drive, use a suitable tool (for example, small pliers) to carefully pull out the lock.

5

Electrical installation

Contents of this chapter

This chapter contains general cabling instructions and instructions on how to connect the FPNO-21 module to the Ethernet network and the drive.

Necessary tools and instructions

Refer to the drive hardware manual.

General cabling instructions

- Arrange the bus cables as far away from the motor cables as possible.
- Avoid parallel runs.
- Use grommets at cable entries.

Connecting the FPNO-21 module to the network

**WARNING!**

Obey the safety instructions of the drive. If you ignore them, injury or death, or damage to the equipment can occur.

The network cable can be CAT5 or higher, braided and foiled shield, with a minimum wire size of AWG 22 / 0.32mm². Use a PROFINET-certified cable. The cable shield is connected to the drive frame through an RC network. Use a dedicated PROFINET-cable for PROFINET installation.



Note: Further information on PROFINET-wiring is available from the PROFIBUS organization publications at <https://www.profibus.com/download/profinet-installation-guidelines/>

- Design guideline, Order no. 8.062
 - Installation guideline for cabling and assembly, Order no. 8.072
 - Commissioning guide, Order no. 8.082
1. Connect the network cable to the RJ-45 connector (X1) on the adapter module.
 2. If you want to create a daisy chain with FPNO-21 modules, connect the X2 connector of the first adapter module to X1 on the next adapter module, and so on.

Note: If a device in the daisy chain is powered off or fails, the rest of the chain is disconnected from the network. In applications where this is not acceptable, consider using ring topology instead.



6

PROFINET IO – Start-up

Contents of this chapter

This chapter contains:

- information on how to configure the drive for operation with the module
- drive-specific instructions on how to start-up the drive with the module
- examples of configuring the master station for communication with the module.

Warnings

**WARNING!**

Obey the safety instructions given in this manual and the drive documentation.

Drive configuration

This information applies to all drive types that are compatible with the FPNO-21 module, unless otherwise stated.

■ PROFINET IO connection configuration

After the FPNO-21 module is mechanically and electrically installed, prepare the drive for communication with the module.

The procedure to set the module for PROFINET IO communication with the drive depends on the drive type. Typically, you must set the PROFINET parameters to establish the communication. Refer to [Starting up fieldbus communication for drives \(page 39\)](#).

When the communication between the drive and the FPNO-21 module is established, the user can see several configuration parameters. These parameters are listed in the

tables below. Examine the parameters and adjust them if it is necessary. You can adjust the parameters through a drive control panel, a web user interface, or a PC tool.

- The new parameter settings take effect only when you power up the module the next time or when you activate the fieldbus adapter refresh parameter.

FPNO-21 configuration parameters – group A (group 1)

Note: The actual parameter group number depends on the drive type. Group A (group 1) corresponds to:

- parameter group 51 in ACS380, ACS480, ACH580, ACQ580 and ACS580.
- parameter group 51 in ACS880 if the adapter is installed as fieldbus adapter A or group 54 if the adapter is installed as fieldbus adapter B.

No.	Name/Value	Description	Default
01	FBA type	Read-only. Shows the fieldbus adapter type as detected by the drive. The value cannot be adjusted by the user. If the value is 0 = None, the communication between the drive and the module has not been established.	132 = PROFINET IO
02	Protocol.Profile	Selects the application protocol and communication profile for the network connection. The selections available for PROFINET IO communication are listed below.	11 = PNIO ABB Pro
	10 = PNIO Pdrive	PROFINET IO protocol: PROFIdrive profile	
	11 = PNIO ABB Pro	PROFINET IO protocol: ABB Drives profile	
	12 = PNIO T16	PROFINET IO protocol: Transparent 16-bit profile	
	13 = PNIO T32	PROFINET IO protocol: Transparent 32-bit profile	
	14 = PNIO PdriveM	PROFINET IO protocol: PROFIdrive positioning mode	
	15 = PNIO Pdrive v4.2	PROFINET IO protocol: PROFIdrive v4.2 profile	
03	Commrate	Sets the bit rate for the Ethernet interface.	0 = Auto
	0 = Auto	Auto-negotiate	
	1 = 100 Mbps FD	100 Mbps, full-duplex	
	2 = 100 Mbps HD	100 Mbps, half-duplex	
	3 = 10 Mbps FD	10 Mbps, full-duplex	
	4 = 10 Mbps HD	10 Mbps, half-duplex	

No.	Name/Value	Description	Default
04	IP configuration	Sets the method for configuring the IP address, subnet mask and gateway address for the module. In a PROFINET IO network, the master controller has a Duplicate Address Detection mechanism. Note: It is recommended to use IP setting for PROFINET as Static IP and address 0.0.0.0. Use PLC hardware configuration to set the IP address for each device in the network.	0 = Static IP
	0 = Static IP	Configuration will be obtained from parameters 05...13 or from the PLC via DCP. The DCP protocol allows the master controller to find every PROFINET IO device on a subnet. When the adapter module is configured for the PROFINET IO protocol, the IP address is transferred to the PROFINET IO communication stack. If there is a need to change the IP address configured via DCP, it should be done with a DCP tool, such as Siemens Step7. If some of the other methods are used to change the IP address, the module must be restarted to enable any changes.	
	2 = Temp IP	IP address is set as Temporary through DCP by the controller. Parameters 05...13 shows the set IP. After reboot this setting goes back to static IP and address 0.0.0.0 is taken to use. This setting is not allowed to be set by the user.	
05 ... 08	IP address 1	An IP address is assigned to each IP node on a network. An IP address is a 32-bit number that is typically represented in "dotted decimal" notation consisting of four decimal integers, on the range 0...255, separated by periods. Each integer represents the value of one octet (8-bits) in the IP address. Parameters 05...08 define the four octets of the IP address.	0
	0...255	IP address	

	IP address 4	See parameter 05 IP address 1.	0
	0...255	IP address	

30 PROFINET IO – Start-up

No.	Name/Value	Description	Default	
09	Subnet CIDR	Subnet masks are used for splitting networks into smaller networks called subnets. A subnet mask is a 32-bit binary number that splits the IP address into a network address and host address. Subnet masks are typically represented in either dotted decimal notation or the more compact CIDR notation, as shown in the table below.	0	
	CIDR	Dotted decimal	CIDR	Dotted decimal
	31	255.255.255.254	15	255.254.0.0
	30	255.255.255.252	14	255.252.0.0
	29	255.255.255.248	13	255.248.0.0
	28	255.255.255.240	12	255.240.0.0
	27	255.255.255.224	11	255.224.0.0
	26	255.255.255.192	10	255.192.0.0
	25	255.255.255.128	9	255.128.0.0
	24	255.255.255.0	8	255.0.0.0
	23	255.255.254.0	7	254.0.0.0
	22	255.255.252.0	6	252.0.0.0
	21	255.255.248.0	5	248.0.0.0
	20	255.255.240.0	4	240.0.0.0
	19	255.255.224.0	3	224.0.0.0
	18	255.255.192.0	2	192.0.0.0
	17	255.255.128.0	1	128.0.0.0
16	255.255.0.0			
1...31	Subnet mask in CIDR notation			
10	GW address 1	IP gateways connect individual physical IP subnets into a unified IP network. When an IP node needs to communicate with an IP node on another subnet, the IP node sends the data to the IP gateway for forwarding. Parameters 10...13 define the four octets of the gateway address.	0	
...				
13	0...255			GW address

	GW address 4			See parameter 10 GW address 1.
	0...255	GW address		

No.	Name/Value	Description	Default
14	Commrte 2	Sets the bit rate for the Ethernet port 2.	0 = Auto
	0 = Auto	Autonegotiate	
	1 = 100 Mbps FD	100 Mbps, full-duplex	
	2 = 100 Mbps HD	100 Mbps, half-duplex	
	3 = 10 Mbps FD	10 Mbps, full-duplex	
	4 = 10 Mbps HD	10 Mbps, half-duplex	
	5 = Disable Port	Disable Ethernet port. ABB recommends to disable the second port if it is not in use.	

No.	Name/Value	Description	Default
15	Service configuration	<p>Disables services that are not required.</p> <p>Each service is represented by a single bit. Bit 0, Lock configuration, can be used to prevent accidental changing of this parameter.</p> <p>By default, all services are enabled and configuration is unlocked.</p> <p>ABB recommends to disable all services that are not used after commissioning.</p>	
	Bit	Name	Information
	0	Lock configuration	Changing this bit to one will lock service configuration and no bit can be changed. Only resetting the fieldbus configuration will unlock the parameter. To reset the fieldbus configuration, choose "Reset all fieldbus settings" or "Clear all" in parameter 96.06 Parameter restore.
	1	Disable IP configuration tool	When this bit is set, access from ABB IP Configuration tool is prevented.
	2	Disable ETH tool network	When this bit is set, access from Ethernet tool network (eg, ABB Drive Composer tool) is prevented.
	3	Disable ping response	When this bit is set, response to ICMP (ping) message is prevented.
	4	Unsecured ETH tool network	When this bit is set, access from Ethernet tool network is unsecured. Note: Drive Composer pro before V2.7 supports unsecured communication only.
	5	Disable configuring web pages	When this bit is set, access to web pages is disabled.
	6	Web-based firmware update	When this bit is set, the web-based firmware update is disabled.
	7	Disable OPC UA	When this bit is set, the OPC UA server is disabled. OPC UA is not enabled by default. For more information, refer to Appendix E - OPC UA server (page 173) .
8	Unencrypted OPC UA	When this bit is set, connection to the OPC UA server is unencrypted.	
	000000b ... 111111b	Service configuration	
16	Module emulation	Emulation mode for PROFINET IO identification data of FENA modules. Activates/inactivates the emulation mode, and selects the PROFINET IO identification data for the emulation. Refer to Emulation modes .	0 = No emulation
	0 = No emulation	FPNO-21 native identification data used. Use FPNO-21 GSDML to configure PLC.	

No.	Name/Value	Description	Default
	1 = FENA-01	FENA-01 identification data used. Use when PLC is configured for FENA-01. Connect only port 1 to Profinet network.	
	2 = FENA-11	FENA-11 identification data used. Use when PLC is configured for FENA-11. Connect only port 1 to Profinet network.	
	3 = FENA-21	FENA-21 identification data used. Use when PLC is configured for FENA-21.	
	4 = VIK-NAMUR	VIK-NAMUR identification data used. Use when PLC is configured for VIK-NAMUR drive.	
17 18	Reserved	These parameters are not used by the adapter module when the module is configured for PROFINET IO.	N/A
19	T16 scale	Defines the scaling for reference 1 and actual 1 with Transparent 16 profile. (Protocol.Profile = PNIO T16) Scaling also depends on the selected Reference type on 50.04 FBA A Ref 1 type and 50.34 FBA B Ref 1 type and 50.07 and 50.37 for the actual 1. Ref type = Transparent $FBA_A/B_Ref1 = Ref1_from_PLC * (T16_Scale + 1)$ Ref type = General $FBA_A/B_Ref1 = Ref1_from_PLC * (T16_Scale + 1) / 100$	99
	0...65535	Reference multiplier/actual value divisor	
20	Telegram type	Read-only. Indicates the telegram type selected for PROFINET IO communication. The adapter module automatically detects the telegram type defined in the PLC. For more information on the supported PPO message types, refer to PPO types (page 101) .	0 = Unknown
	0 = Unknown	Cyclical communication between the master and the module has not been established yet.	
	3 = PPO3	PPO3 selected	
	4 = PPO4	PPO4 selected	
	6 = PPO6	PPO6 selected	
	7 = PPO7	PPO7 selected	
	8 = ST1	ST1 selected	
	9 = ST2	ST2 selected	
	20 = ST20	Standard Telegram 20. Visible only in VIK-NAMUR emulation mode.	

34 PROFINET IO – Start-up

No.	Name/Value	Description	Default
21	Diagnostic alarm	Disables the PROFIdrive alarm mechanism which generates alarms in case of drive faults. But the standard PROFINET alarms are still sent. For more information on the diagnostics and alarm mechanism for PROFIdrive, refer to Diagnostic and alarm mechanism (page 121) .	0 = Enabled
	0 = Enabled	PROFIdrive alarms are enabled.	
	1 = Disabled	PROFIdrive alarms are disabled.	
22	Map selection	Defines the preferred data type of mapped parameters when mapping is done through PROFIdrive parameters.	1 = 16bit
	0 = 32bit	32 bits	
	1 = 16bit	16 bits	
23 ... 24	Reserved	This parameter is not used by the adapter module when the module is configured for PROFINET IO.	N/A
25	PN Name Index	<p>Allows to use pre-defined format of the PROFINET station name.</p> <p>By default this value is 0 and the station name is set from the network. When the value is set to other than 0, the PROFINET station name is overwritten in the format “abbdrive-xx”, where xx is the value of the parameter name index.</p> <p>Example: Setting this value to 12 results in the name “abbdrive-12”.</p> <p>Note: During every boot the FPNO-21 module checks the value of PN Name Index,</p> <ul style="list-style-type: none"> • If the value is not Zero then the active PN Name Index overrides the PROFINET station name. • If the new name is set by DCP Set command as permanent, the new name is used and stored to flash. The PN Name Index parameter value is not changed, so after next boot, the name is taken according to the PN Name Index. • If the new name is set by DCP Set command as temporary, the new name is used and the empty name is stored to flash. The PN Name Index parameter value is not changed, so after next boot name is taken according to the PN Name Index. • The PROFINET DCP factory reset also resets the PN Name Index value to default (0). 	0
	0...65535		
26	Reserved	Reserved for web page functionality. For more information, see Appendix C - FPNO-21 configuration web pages (page 155) .	N/A

No.	Name/Value	Description	Default
27	FBA A/B par refresh	Validates any changed adapter module configuration parameter settings. After refreshing, the value reverts automatically to 0 = Done. Note: This parameter cannot be changed while the drive is running.	0 = Done
	0 = Done	Refreshing done	
	1 = Refresh	Refreshing	
28	FBA A/B par table ver	Read-only. Displays the parameter table revision of the fieldbus adapter module mapping file stored in the memory of the drive. In format xyz , where x = major revision number y = minor revision number z = correction number OR in format axyz , where a = major revision number xy = minor revision numbers z = correction number or letter.	N/A
		Parameter table revision	
29	FBA A/B drive type code	Read-only. Displays the drive type code of the fieldbus adapter module mapping file stored in the memory of the drive.	N/A
		Drive type code of the fieldbus adapter module mapping file	
30	FBA A/B mapping file ver	Read-only. Displays the fieldbus adapter module mapping file revision stored in the memory of the drive in decimal format.	N/A
		Mapping file revision	
31	D2FBA A/B comm status	Read-only. Displays the status of the fieldbus adapter module communication. Note: The value names may vary by drive. Note: Only active drive-controlled channel will change comm status <i>online</i> . PROFIsafe alone will not change the comm status.	0 = Idle or 4 = Offline
	0 = Idle	Adapter is not configured	
	1 = Exec.init	Adapter is initializing.	
	2 = Time out	A timeout has occurred in the communication between the adapter and the drive.	
	3 = Conf.err	There is an internal error in the communication between the adapter and the drive. Contact your local ABB representative.	
	4 = Off-line	Adapter is off-line	
	5 = On-line	Adapter is on-line	
	6 = Reset	Adapter is performing a hardware reset.	

No.	Name/Value	Description	Default
32	FBA A/B comm SW ver	Read-only. Displays patch and build numbers of the adapter module's firmware version in xyy format, where: xx = patch number yy = build number. Example: If the firmware version (<major>.<minor>.<patch>.<build>) is 3.10.200.13, the value C80D is displayed. If the version is 3.10.0.0, the value 0 is displayed. See also parameter 33.	N/A
33	FBA A/B appl SW ver	Read-only. Displays major and minor revision numbers of the adapter module's firmware version in xyy format, where: xx = major revision number yy = minor revision number Example: If the firmware version (<major>.<minor>.<patch>.<build>) is 3.10.200.13 or 3.10.0.0, the value 310 is displayed. See also parameter 32.	N/A

FPNO-21 configuration parameters – group B (group 2)

Note: The actual parameter group number depends on the drive type. Group B (group 2) corresponds to:

- parameter group 53 in ACS380, ACS480, ACH580, ACQ580 and ACS580
- parameter group 53 in ACS880 if the adapter is installed as fieldbus adapter A or group 56 if the adapter is installed as fieldbus adapter B.

No. ¹⁾	Name/Value	Description	Default
01	FBA data out 1 (master to drive)	Selects the resolution of control word (16 bit or 32 bit) received by the drive.	1 or 11 ²⁾
	1 = CW 16bit	Control word (16 bits)	
	11 = CW 32bit	Control word (32 bits)	

No. ¹⁾	Name/Value	Description	Default						
02	FBA data out 2	Selects data word 1 received by the drive over the PROFINET network. The content is defined by a decimal number in the range of 0 to 9999 as follows: <table border="1" data-bbox="638 414 1204 571"> <tr> <td>0</td> <td>Not used</td> </tr> <tr> <td>1...99</td> <td>Virtual address area of drive control</td> </tr> <tr> <td>101...9999</td> <td>Parameter area of the drive</td> </tr> </table>	0	Not used	1...99	Virtual address area of drive control	101...9999	Parameter area of the drive	0 or 2
	0	Not used							
	1...99	Virtual address area of drive control							
	101...9999	Parameter area of the drive							
	0 = None	Not used							
	1 = CW 16bit	Control word (16 bits)							
	2 = Ref1 16bit	Reference REF1 (16 bits)							
	3 = Ref2 16bit	Reference REF2 (16 bits)							
	11 = CW 32bit	Control word (32 bits)							
	12 = Ref1 32bit	Reference REF1(32 bits)							
13 = Ref2 32bit	Reference REF2 (32 bits)								
21 = CW2 16bit	Control word 2 (16 bits)								
101...9999	Parameter index with format xyyy , where <ul style="list-style-type: none"> xx is the parameter group number (1...99) yy is the parameter number index within that group (01...99). 								
Other	Path to parameter area selection.								
03 ... 10	FBA data out 3 ... FBA data out12	See parameter 02 FBA data out 1.	0						

¹⁾ The number of parameters in this group may vary by drive type and drive firmware.

²⁾ 11 (CW 32bit) is the default setting if the Transparent32 profile is used.

FPNO-21 configuration parameters – group C (group 3)

Note: The actual parameter group number depends on the drive type. Group C (group 3) corresponds to:

- parameter group 52 in ACS380, ACS480, ACH580, ACQ580 and ACS580
- parameter group 52 in ACS880 if the adapter is installed as fieldbus adapter A or group 55 if the adapter is installed as fieldbus adapter B.

No. ¹⁾	Name/Value	Description	Default
01	FBA data in 1 (drive to master)	Selects the resolution of status word (16 bit or 32 bit) sent by the drive.	4 or 14 ²⁾
	4 = SW 16bit	Status word (16 bits)	
	14 = SW 32bit	Status word (32 bits)	

No. ¹⁾	Name/Value	Description	Default						
02	FBA data in 2 (drive to master)	Selects data word 1 sent by the drive over the PROFINET network. The content is defined by a decimal number in the range of 0 to 9999 as follows: <table border="1" style="margin-left: 20px;"> <tr> <td>0</td> <td>Not used</td> </tr> <tr> <td>1...99</td> <td>Virtual address area of drive control</td> </tr> <tr> <td>101...9999</td> <td>Parameter area of the drive</td> </tr> </table>	0	Not used	1...99	Virtual address area of drive control	101...9999	Parameter area of the drive	0 or 5
0	Not used								
1...99	Virtual address area of drive control								
101...9999	Parameter area of the drive								
	0 = None	Not used							
	4 = SW 16bit	Status word (16 bits)							
	5 = Act1 16bit	Actual value ACT1 (16 bits)							
	6 = Act2 16bit	Actual value ACT2 (16 bits)							
	14 = SW 32bit	Status word (32 bits)							
	15 = Act1 32bit	Actual value ACT1 (32 bits)							
	16 = Act2 32bit	Actual value ACT2 (32 bits)							
	24 = SW2 16bit	Status word 2 (16 bits)							
	101...9999	Parameter index with format xxyy , where <ul style="list-style-type: none"> • xx is the parameter group number (1...99) • yy is the parameter number index within that group (01...99). 							
	Other	Path to parameter area selection.							
03 ... 10	DATA IN 3... DATA IN 12	Refer to parameter 01 FBA data in 1.	0						

¹⁾ The number of parameters in this group may vary by drive type and drive firmware.

²⁾ 14 (SW 32bit) is the default setting if the Transparent32 profile is used.

Emulation modes

The FPNO-21 module supports emulation modes for FENA-01, FENA-11 or FENA-21 Ethernet adapter modules, or a drive with the VIK-NAMUR control program. In emulation mode, the FPNO-21 module changes its identification information to accept connections from a PLC which is configured to communicate with FENA-01, FENA-11 or FENA-21 module, or drive with the VIK-NAMUR control program.

VIK-NAMUR mode

You can use the VIK-NAMUR mode in combination with the drive with the VIK-NAMUR control program. With this mode, FPNO-21 acts in the transparent mode and the drive control program provides cyclic data content for Standard Telegram 20. Use this mode with the generic VIK-NAMUR GSDML file.

■ Control locations

ABB drives can receive control information from multiple sources including digital inputs, analog inputs, the drive control panel and a fieldbus adapter module. ABB

drives allow the user to separately determine the source for each type of control information (Start, Stop, Direction, Reference, Fault reset, and so on).

To give the fieldbus master the most complete control over the drive, select the adapter module as the source of this information. The drive-specific parameter setting examples below contain the drive control parameters that are relevant in the examples. For a complete parameter list, refer to the drive documentation.

Starting up fieldbus communication for drives

1. Power up the drive.
 2. To enable the communication between the adapter module and the drive, select the correct slot number in parameter 50.01 FBA A enable.
The selection must correspond to the slot where the adapter module is installed. For example, if the adapter module is installed in slot 2, select "slot 2".
 3. With parameter 50.02 FBA A comm loss func, select how the drive reacts to a fieldbus communication break.
Note that this function monitors both communication between the fieldbus master and the adapter module and communication between the adapter module and the drive.
 4. With parameter 50.03 FBA A comm loss t out, define the time between communication break detection and the selected action.
 5. Select application-specific values for the rest of the parameters in group 50, starting from 50.04.
Examples of appropriate values are shown in the tables below.
 6. Set the module configuration parameters in group 51.
At the minimum, select the communication protocol and profile with parameter 51.02 Protocol/Profile and configure the network settings with parameters 51.03...51.13.
 7. Deactivate all services that are not used in the installation with parameter 51.15 Service configuration.
 8. Define the process data transferred to and from the drive in parameter groups 52 and 53.
Note: The adapter module automatically sets the communication profile-specific virtual address for the Status word in parameter 52.01 and for the Control word in parameter 53.01.
 9. Save the valid parameter values to permanent memory with parameter 96.07 Parameter save manually.
 10. Validate the settings in parameter groups 51, 52 and 53 with parameter 51.27 FBA A par refresh.
 11. Set the relevant drive control parameters to control the drive according to the application.
Examples of appropriate values are shown in the tables below.
-

Parameter setting examples – ACS380, ACS480, ACH580, ACQ580, and ACS580

■ Frequency control using PROFIdrive communication profile with PPO Type 4

This example shows how to configure a basic frequency control application that uses the PROFIdrive profile. In addition, some application-specific data is added to the communication.

The start/stop commands and reference are according to the PROFIdrive profile, speed control mode. For more information, refer to the PROFIdrive state machine on page 85.

The reference value ± 16384 (4000h) corresponds to parameter **46.02 Frequency scaling** in the forward and reverse directions.

Direction	PZD1	PZD2	PZD3	PZD4	PZD5	PZD6
Out	Control word	Frequency reference	Constant frequency 1 ¹⁾		Constant frequency 2 ¹⁾	
In	Status word	Frequency actual value	Power ¹⁾		DC bus voltage ¹⁾	

1) Example

The table gives an example of the drive parameter settings.

Drive parameter	Setting for drives	Description
50.01 FBA A enable	1 = Enable	Enables communication between the drive and the fieldbus adapter module.
50.04 FBA A ref1 type	5 = Frequency	Selects the fieldbus A reference 1 type and scaling.
50.07 FBA A act1 type	5 = Frequency	Selects the actual value type and scaling according to the currently active Ref1 mode defined in parameter 50.04.
51.01 FBA A type	132 = PROFINET IO ¹⁾	Displays the type of the fieldbus adapter module.
51.02 Protocol/Profile	10 = PNIO Pdrive	Selects the PROFINET IO protocol and the PROFIdrive profile.
51.03 Commrate	0 = Auto	Ethernet communication rate is negotiated automatically by the device.
51.04 IP configuration	0 = Static IP	Configuration will be obtained from parameters 51.05...13 or from the PLC via the DCP protocol.
52.01 FBA DATA IN1	4 = SW 16bit	Status word
52.02 FBA DATA IN2	5 = Act1 16bit	Actual value 1
52.03 FBA data in3	01.14	Output power
52.05 FBA data in5	01.11	DC voltage
53.01 FBA DATA out1	1 = CW 16bit	Control word

Drive parameter	Setting for drives	Description
53.02 FBA DATA out2	2 = Ref1 16bit	Reference 1 (frequency)
53.03 FBA data out3	28.26	Constant frequency 1
53.05 FBA data out5	28.27	Constant frequency 2
51.27 FBA A par refresh	1 = Refresh	Validates the configuration parameter settings.
19.12 Ext1 control mode	2 = Speed	Selects speed control as the control mode 1 for external control location 1.
20.01 Ext1 commands	12 = Fieldbus A	Selects the fieldbus A interface as the source of the start and stop commands for external control location 1.
22.11 Speed ref1 source	4 = FB A REF1	Selects the fieldbus A reference 1 as the source for speed reference 1.

¹⁾ Read-only or automatically detected/set

The start sequence for the parameter example above is given below.

Control word:

- Reset the fieldbus communication fault (if active).
- Enter 47Eh (1150 decimal) → READY TO SWITCH ON.
Enter 47Fh (1151 decimal) → OPERATING.

Parameter setting examples – ACS880

■ Speed control using PROFIdrive communication profile with PPO Type 4

This example shows how to configure a basic speed control application that uses the PROFIdrive profile. Some application-specific data is added to the communication.

The start/stop commands and reference are according to the PROFIdrive profile, speed control mode. For more information, refer to the PROFIdrive state machine on page 85.

The reference value ± 16384 (4000h) corresponds to parameter **46.01 Speed scaling** in the forward and reverse directions.

Direction	PZD1	PZD2	PZD3	PZD4	PZD5	PZD6
Out	Control word	Speed reference	Constant speed 1 ¹⁾		Constant speed 2 ¹⁾	
In	Status word	Speed actual value	Power ¹⁾		DC bus voltage ¹⁾	

¹⁾ Example

The table below gives an example of the drive parameter settings.

Drive parameter	Setting for drives	Description
50.01 FBA A enable	1 = Option slot 2 ²⁾	Enables communication between the drive and the fieldbus adapter module.

42 PROFINET IO – Start-up

Drive parameter	Setting for drives	Description
50.04 FBA A ref1 type	4 = Speed	Selects the fieldbus A reference 1 type and scaling.
50.07 FBA A act1 type	4 = Speed	Selects the actual value type and scaling according to the currently active Ref1 mode defined in parameter 50.04.
51.01 FBA A type	132 = PROFINET IO ¹⁾	Displays the type of the fieldbus adapter module.
51.02 Protocol/Profile	10 = PNIO Pdrive	Selects the PROFINET IO protocol and the PROFIdrive profile.
51.03 Commrate	0 = Auto ²⁾	Ethernet communication rate is negotiated automatically by the device.
51.04 IP configuration	0 = Static IP	Configuration will be obtained from parameters 51.05...13 or from the PLC via the DCP protocol.
52.01 FBA DATA IN1	4 = SW 16bit	Status word
52.02 FBA DATA IN2	5 = Act1 16bit	Actual value 1
52.03 FBA data in3	01.14	Output power
52.05 FBA data in5	01.11	DC voltage
53.01 FBA DATA out1	1 = CW 16bit	Control word
53.02 FBA DATA out2	2 = Ref1 16bit	Reference 1 (speed)
53.03 FBA data out3	22.26	Constant speed 1
53.05 FBA data out5	22.27	Constant speed 2
51.27 FBA A par refresh	1 = Refresh	Validates the configuration parameter settings.
19.12 Ext1 control mode	2 = Speed	Selects speed control as the control mode 1 for external control location 1.
20.01 Ext1 commands	12 = Fieldbus A	Selects the fieldbus A interface as the source of the start and stop commands for external control location 1.
22.11 Speed ref1 source	4 = FB A REF1	Selects the fieldbus A reference 1 as the source for speed reference 1.

1) Read-only or automatically detected/set

2) Example

The start sequence for the parameter example above is given below.

Control word:

- Reset the fieldbus communication fault (if active).
- Enter 47Eh (1150 decimal) → READY TO SWITCH ON.
Enter 47Fh (1151 decimal) → OPERATING.

Configuring the master station

After the adapter module is initialized by the drive, prepare the master station for communication with the module. Examples of an ABB AC500 PLC and Siemens SIMATIC S7 PLC are given below. If you are using another master system, refer to its documentation.

The examples apply to all drive types that are compatible with the module.

■ Downloading the GSD file

Configuration of the master station requires a type definition (GSD) file. In PROFINET IO, the GSD file is written in XML-based language called GSDML.

Download the FPNO-21 GSD file from the Document library (<http://new.abb.com/drives/connectivity/fieldbus-connectivity/profinet>). The file name format is **GSDML-Vx.x-ABB-FPNO-yyyymmdd.xml**.

The GSD file describes the vendor-specific and PROFIdrive-specific features of the adapter module. Vendor-specific features can be used, for example, in the ABB Drives communication profile. The PROFIdrive profile supports a set of services described in the PROFIdrive specification.

■ Configuring an ABB AC500 PLC

This example shows how to configure communication between an ABB AC500 PLC and the adapter module using Automation builder, software version 2.1.0 and later.

Before you start, make sure that you have downloaded the FPNO-21 GSD file from the Document library.

1. Start the ABB Automation Builder software.
 2. In the **Tools** menu, select **Device Repository**.
 3. In the window that opens, click **Install...** and browse for the GSD file.
-

44 PROFINET IO – Start-up

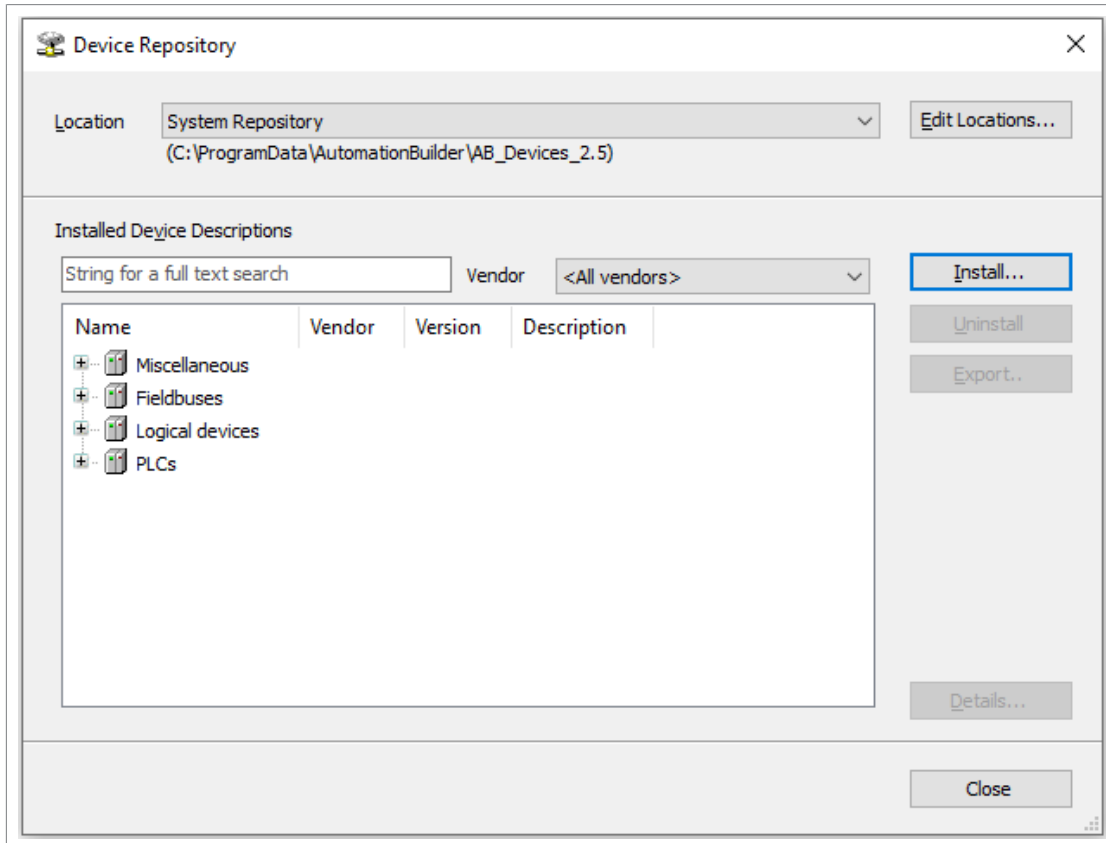

4. Open or create the PLC project that is used to control the drive.
5. Add the CM579-PNIO PROFINET master device to the PLC project, if it is necessary.
6. Add the adapter module to the PROFINET IO network.
7. Add the I/O module, for example, PPO Type 4 to the adapter module to define cyclical communication between the module and the PLC.
8. Define the CM579-PNIO master properties, such as the IP address and address settings for slaves.

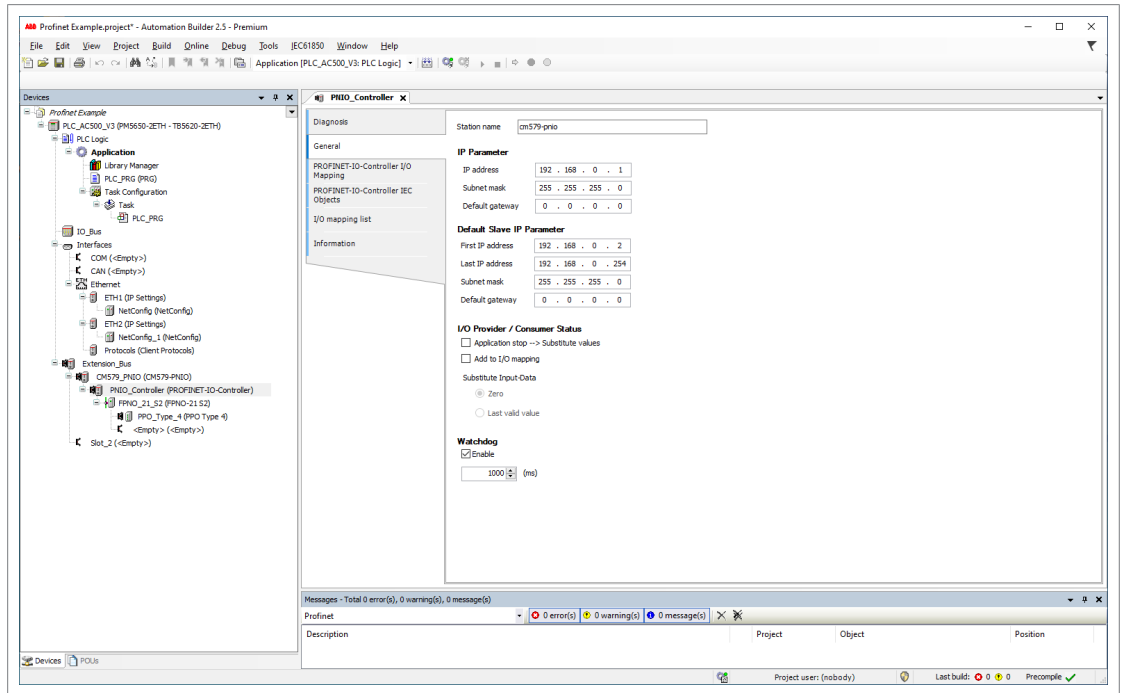

9. Define the adapter module properties:

On the **PNIO identification** tab, select the IP address and Subnet mask, and type the Station name. **Note:** Use only small letters for the Station name.

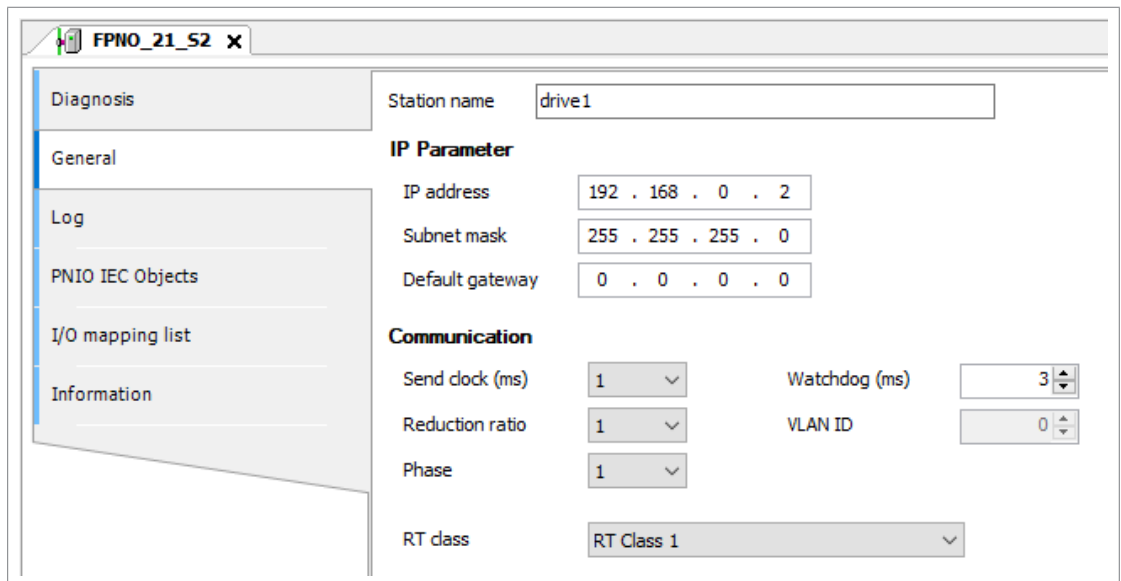

10. Open the PLC program.

11. Compile the project and download it to the PLC.

This is necessary for you to be able to configure the CM579-PNIO master device and allow it to scan the network.

12. Return to the CM579-PNIO master properties. On the **Assign station name** tab, do these tasks:

- Click **Connect to PLC (Login)** and select the communication link between Automation builder and the PLC. Then, click **Scan slaves** to find all PROFINET slaves connected to the network.

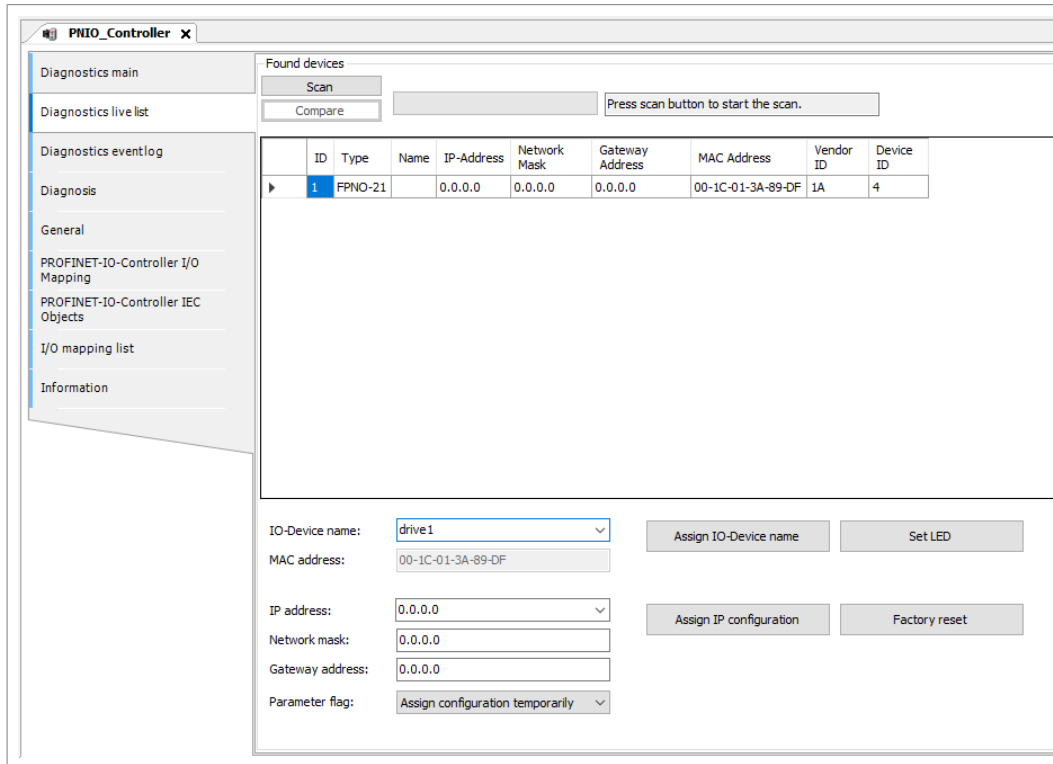

- In the **Configure station name** box, select the station name that was given for the module in step 9, and then click **Assign station name**.
- In the **IP address** and **Network mask** boxes, select/type the IP address and subnet mask defined in step 9, and then click **Assign IP configuration**.

13. Define the I/O module properties:

- On the **PNIO parameters** tab, configure the Stop mode and Control-zero mode functionalities, and define fail safe values for the PLC output process data (PZDs).

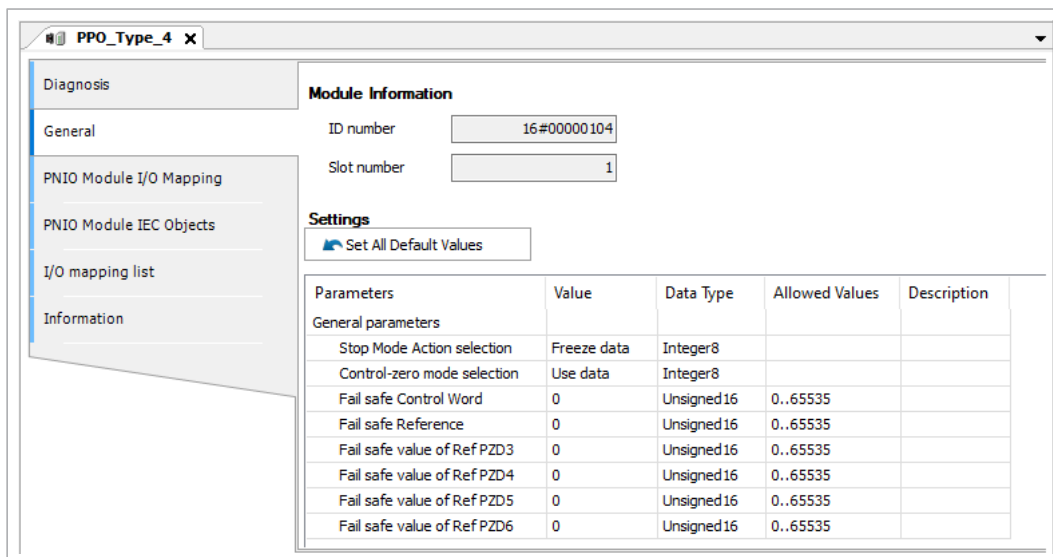

- On the **PNIO Module I/O Mapping** tab, type names for the variables that refer to the drive signals in the PLC program.

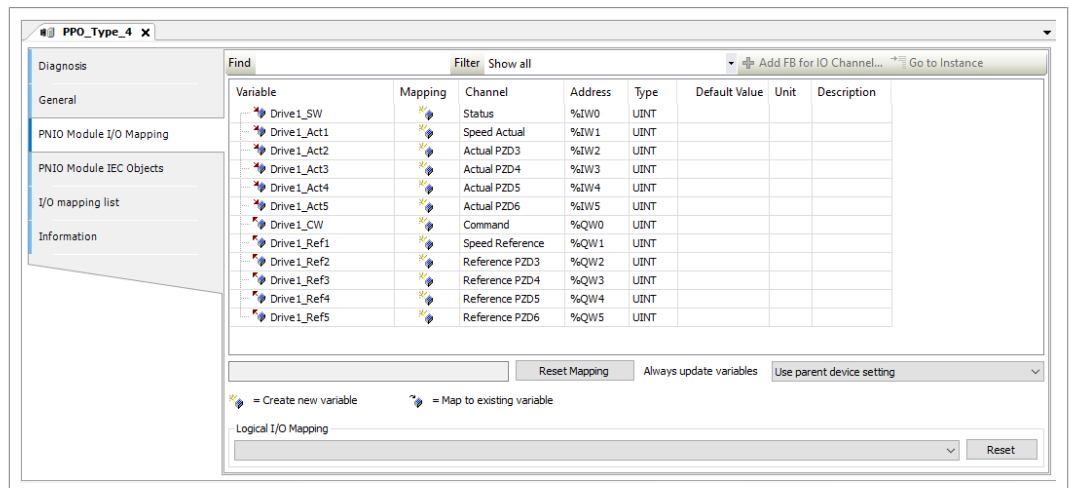

14. Open the PLC program and create a program that controls the drive.
15. Compile the project and download it to the PLC.

Make sure that the variable names defined for the drive signals are used in the PLC program. Otherwise the communication will not work

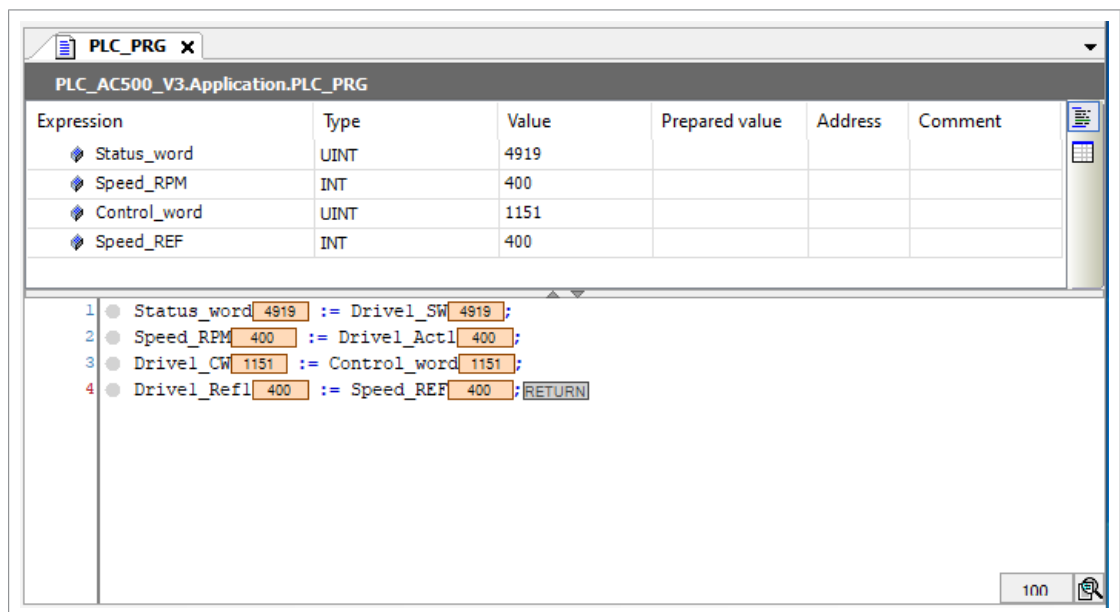

■ Configuring a Siemens SIMATIC S7 PLC

This example shows how to configure communication between a Siemens SIMATIC S7 PLC and the adapter module using SIMATIC Manager Step 7.

Before you start, make sure that you have the FPNO-21 GSD file from the Document library.

1. Start the SIMATIC manager and open/create a SIMATIC program.
2. Open the hardware configuration of the project.

48 PROFINET IO – Start-up

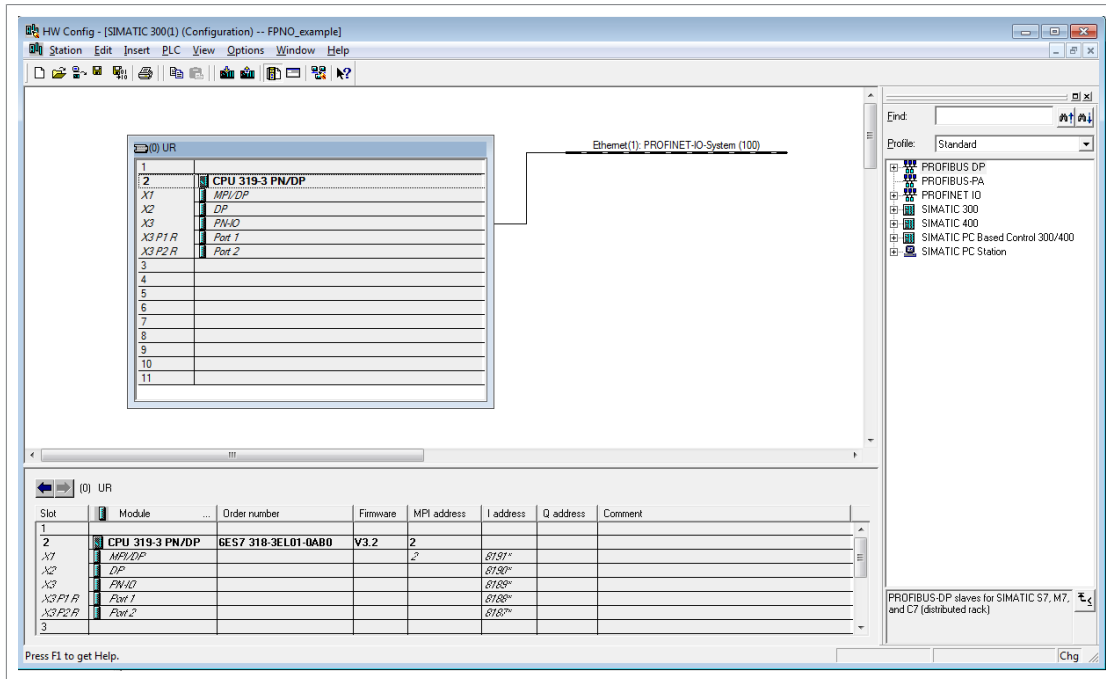

3. Install the FPNO-21 GSD file:

- In the **Options** menu, select **Install GSD Files**.
- Browse for the GSD file downloaded from the Document library and click **Install**.

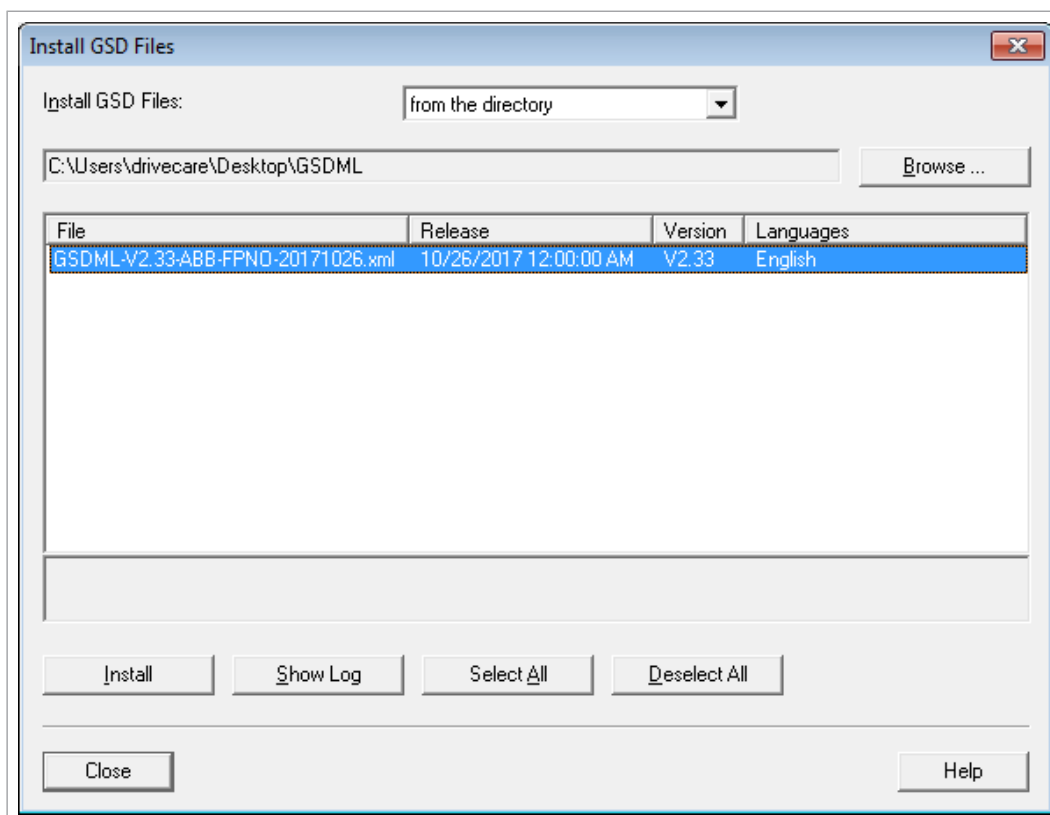

4. Click and drag the FPNO-21 object from the device catalog to the Ethernet (1): PROFINET-IO-System.

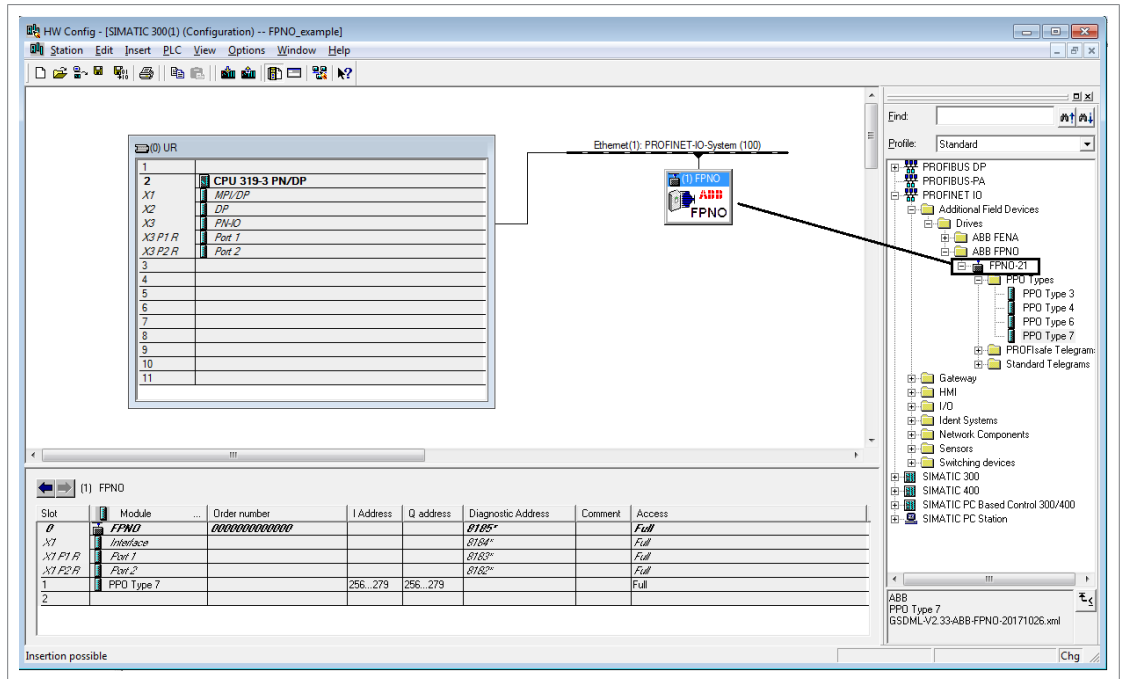

- Click and drag the PP0 Type 7 object to Slot 1. Then, double-click FPNO-21 to open the **Properties** window.

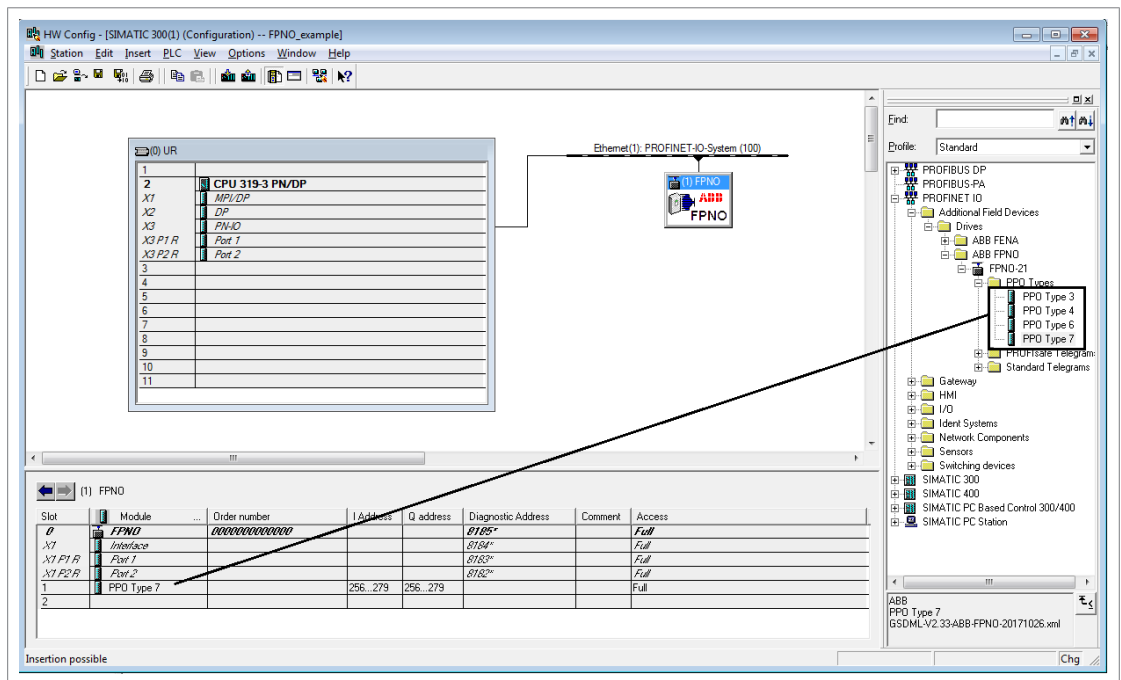

- On the **General** tab, type a name for the adapter module in the **Device name** box.

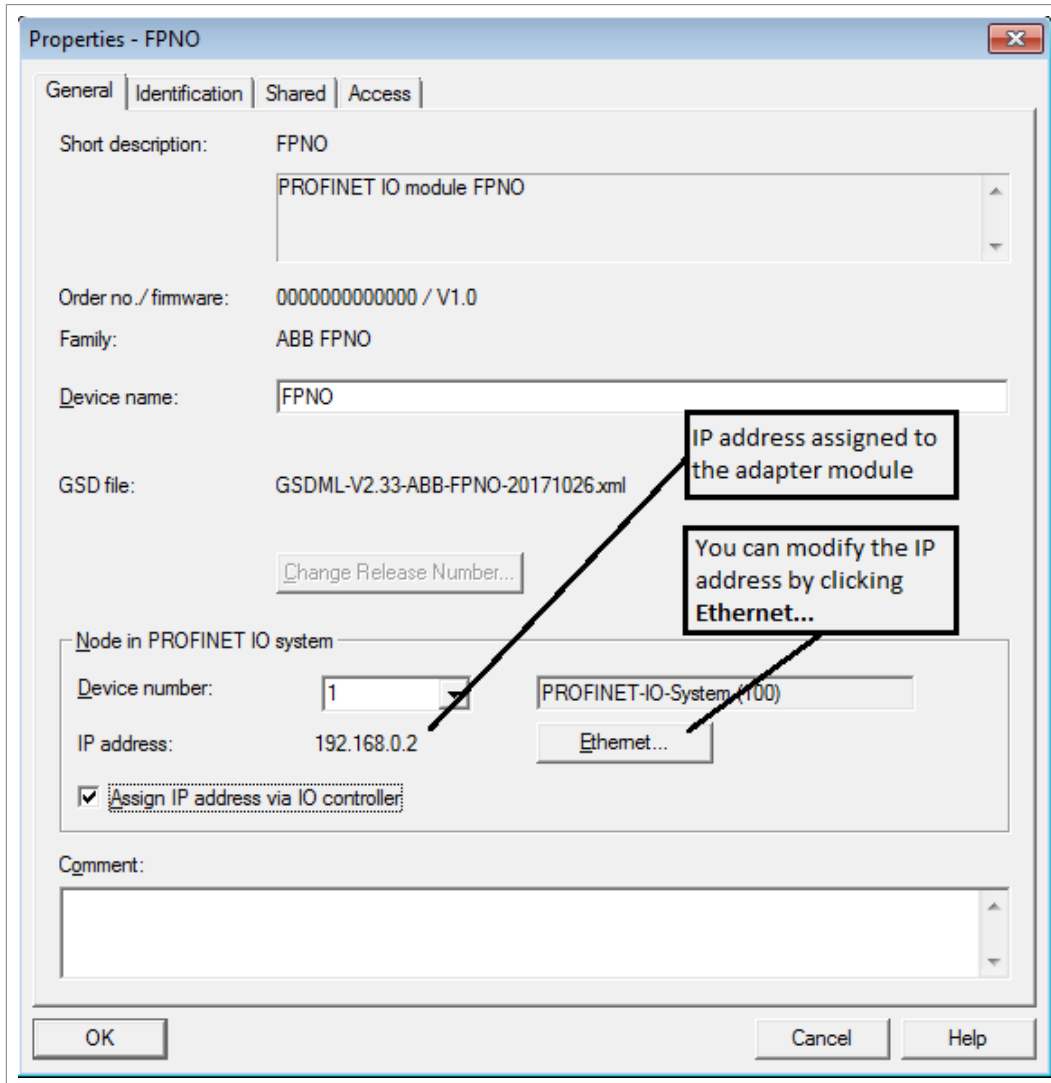

7. In the hardware configuration, double-click PPO Type 7 in Slot 1 to open the **Properties** window.
8. On the **Parameters** tab, configure the stop mode and control-zero mode functionality, and set fail safe values for the PLC output process data (PZDs).

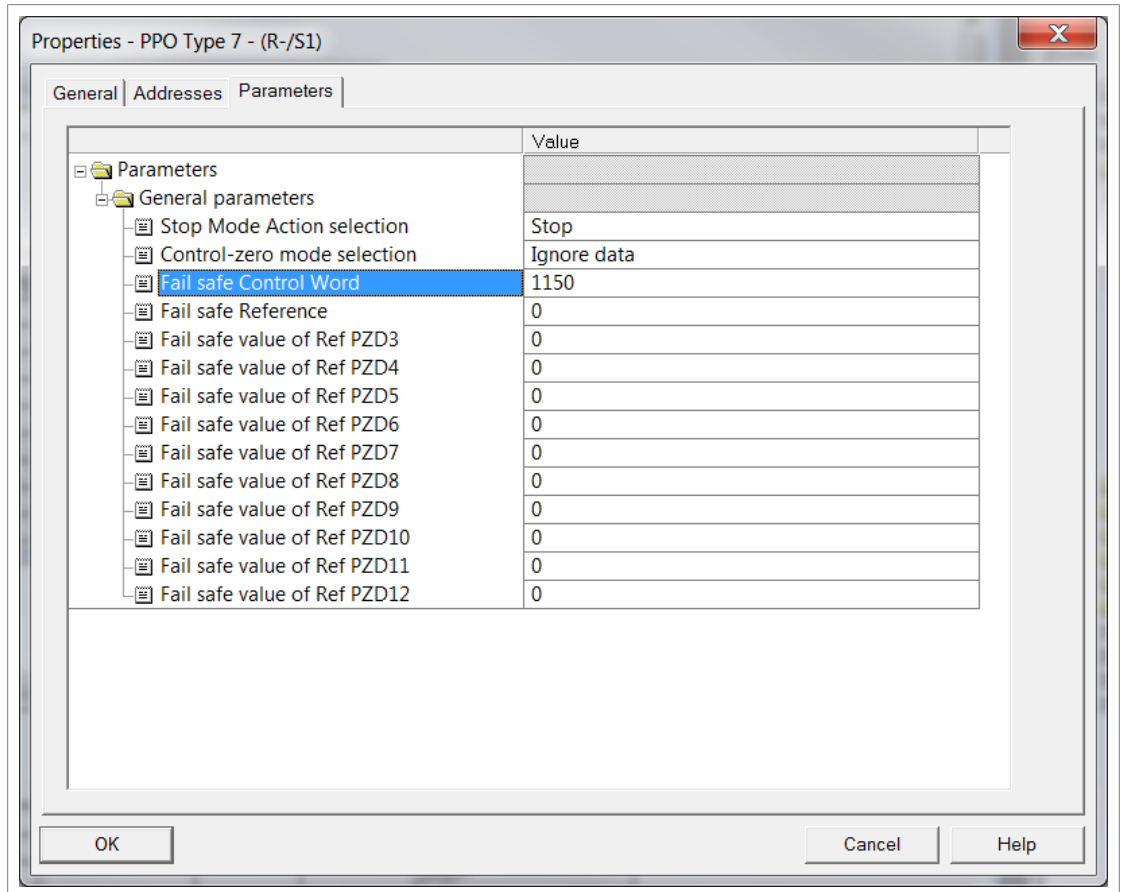

9. Assign the device name (set in step 6) to the adapter module:
 - In the hardware configuration, click FPNO-21.
 - On the **PLC** menu, select **Ethernet**, and then select **Assign Device Name**.

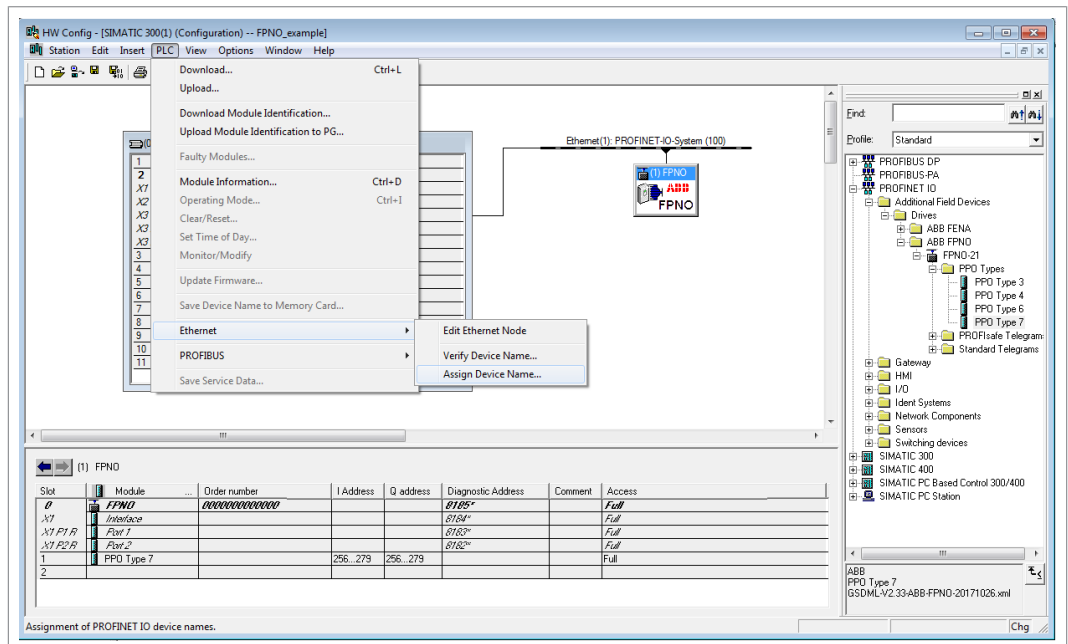

- Click the available device with the correct MAC address to which the device name is to be assigned. This assigns the name to the FPNO-21 adapter module. Then click **Assign name**.

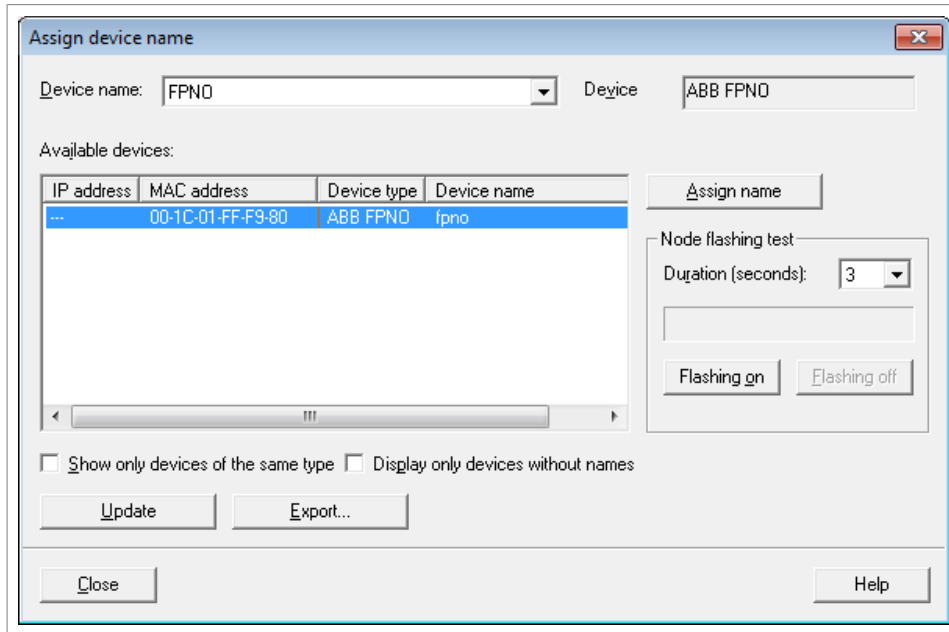

10. Download the hardware configuration to the PLC.

The PLC is now ready for communication with the adapter module.

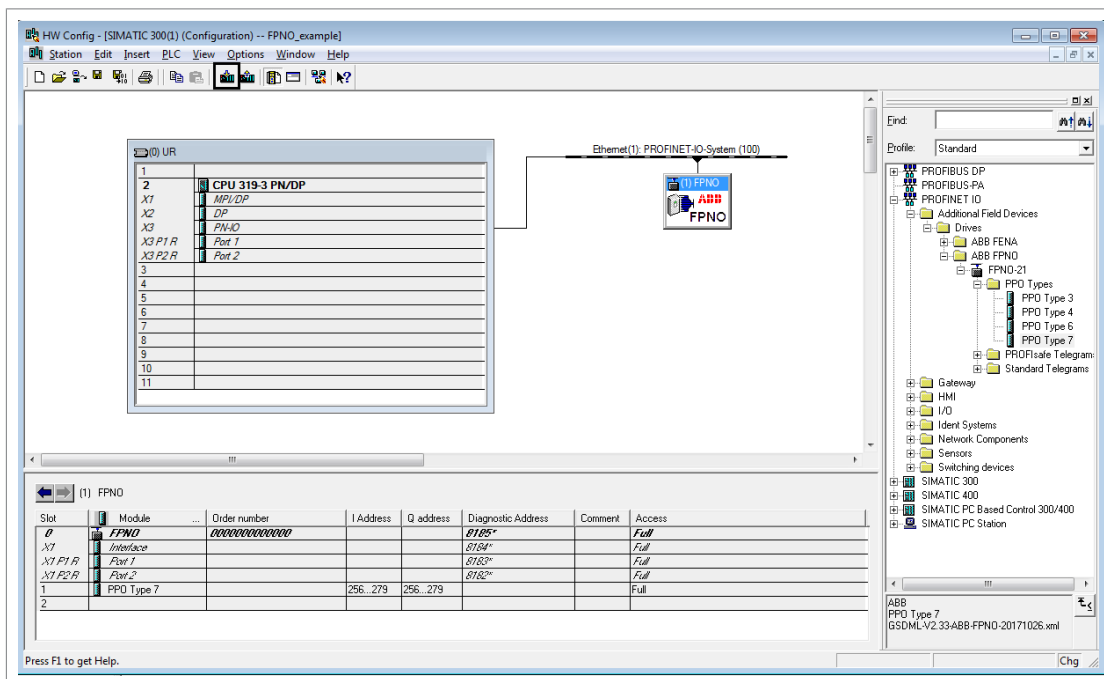

■ Resetting PROFINET IO device to factory default via S7

You can reset the PROFINET IO device to the factory default state.

1. In HW configuration, go to PLC → Ethernet → Edit Ethernet Node.

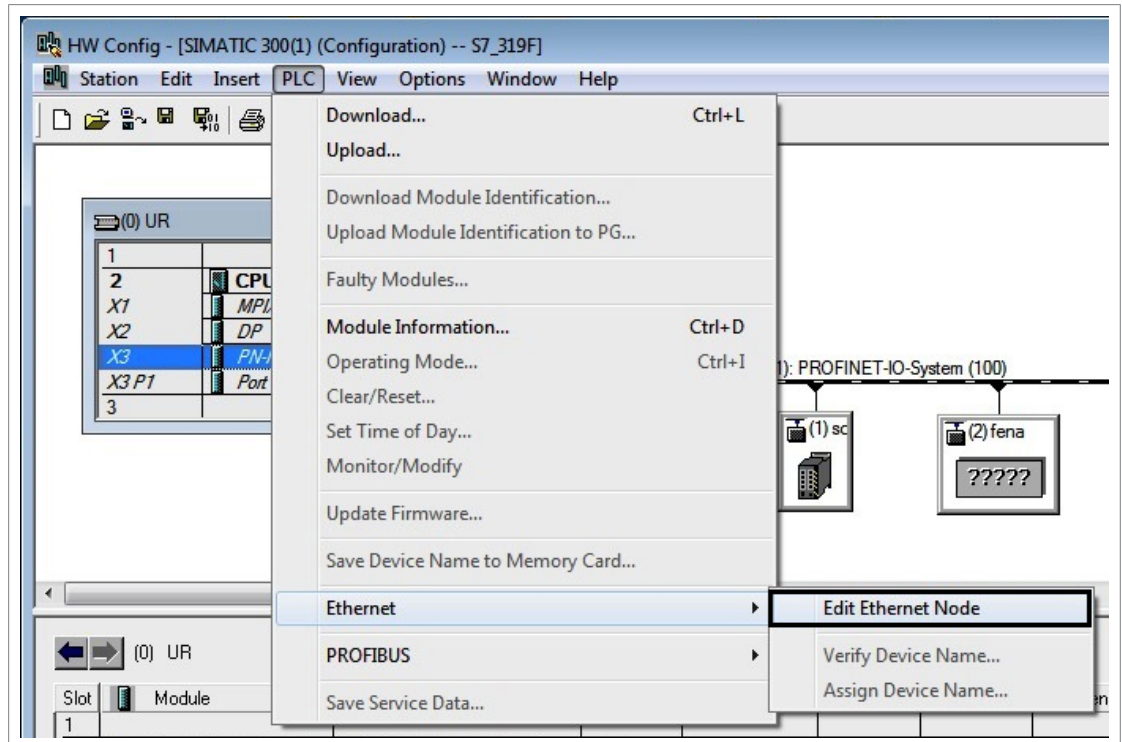

2. In the Edit Ethernet Node window, click **Browse...**

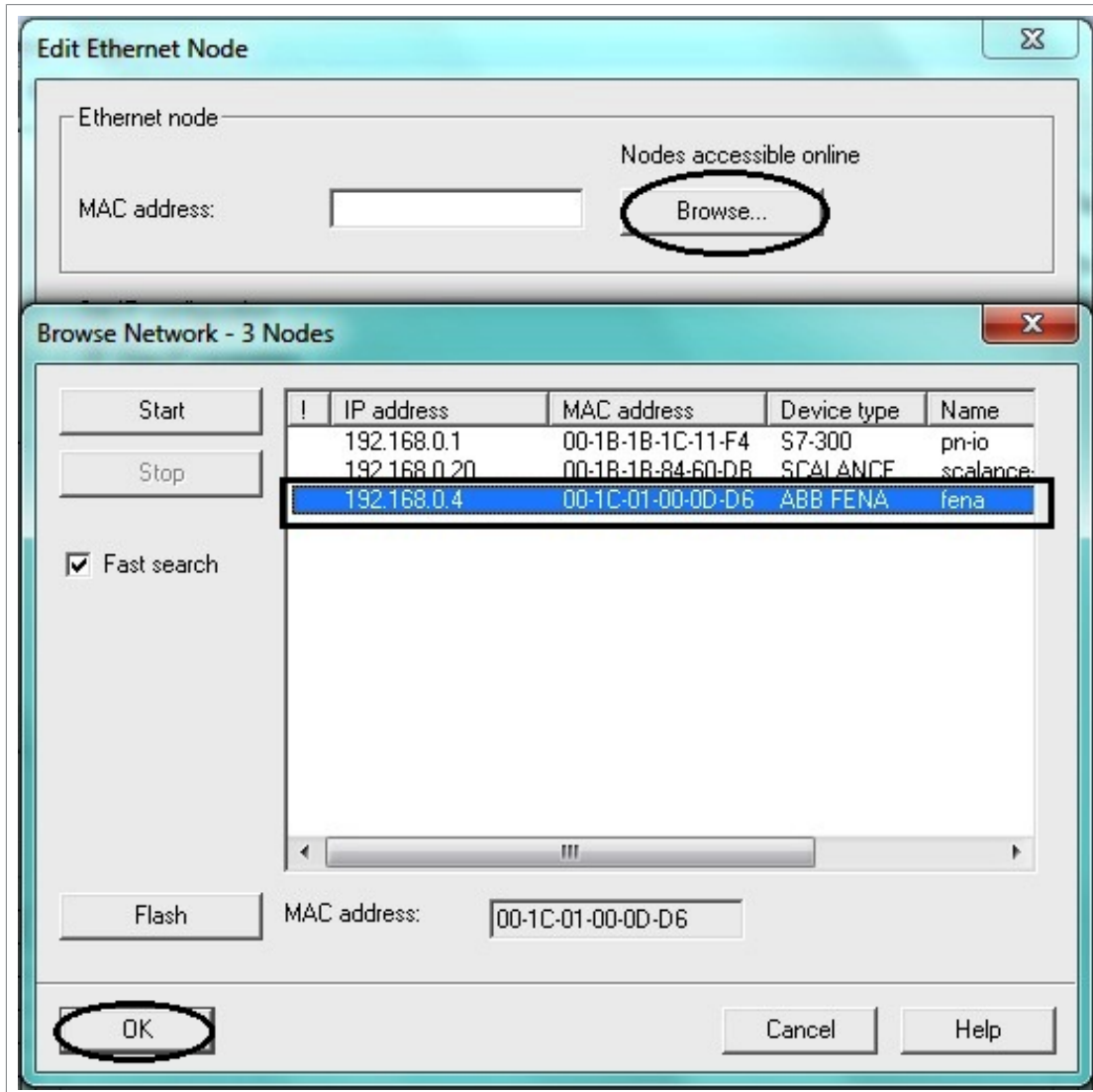

The list of available devices appears.

3. Select the device that needs to be reset to default. Click **OK**.
4. Click **Reset** to clear configuration.

Edit Ethernet Node

Ethernet node

MAC address:

Nodes accessible online

Set IP configuration

Use IP parameters

IP address: Gateway

Subnet mask: Do not use router

Use router

Address:

Obtain IP address from a DHCP server

Identified by

Client ID MAC address Device name

Client ID:

Assign device name

Device name:

Reset to factory settings

5. A pop-up window appears when the reset starts. Click **OK**.

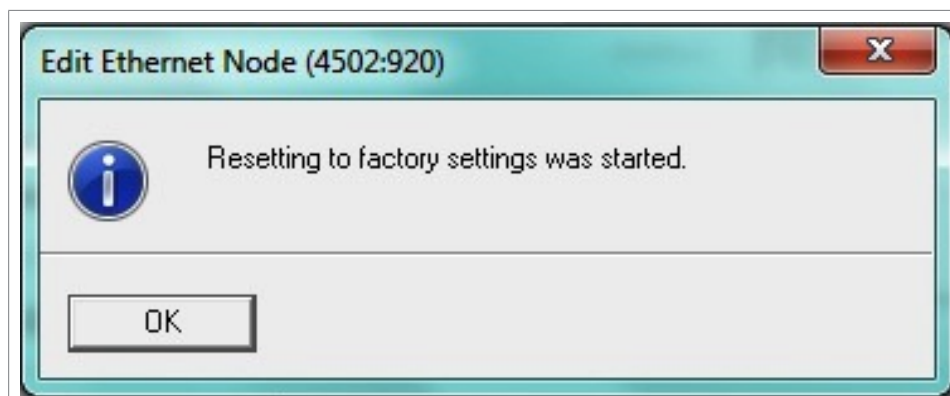

The configuration is now reset to the default settings (PROFINET IO station name, Ethernet services configuration).

■ Configuring a Siemens PLC with TIA14

This example shows how to configure communication between a Siemens SIMATIC S7 PLC and the adapter module using SIMATIC Manager Step 7.

Before you start, make sure that you have the FPNO-21 GSD file from the Document library.

1. Start TIA14 and create new project.
2. Change to project view.
3. Install the FPNO-21 GSD file:
 - Options > Manage general station description files
 - Browse to source path where GSDML file is located.
 - Select the check box and click Install.
4. Add new device and select CPU from list.

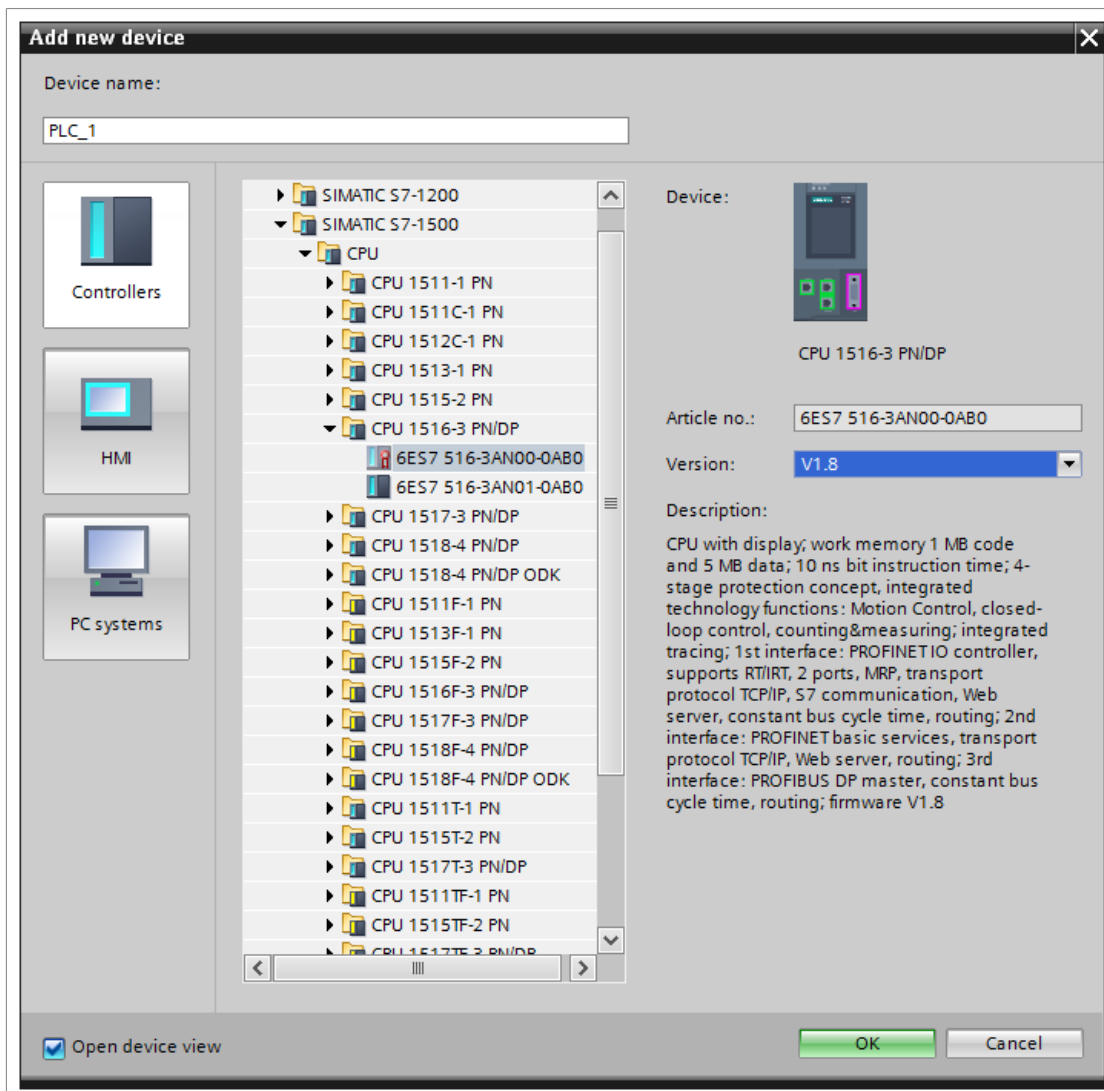

5. Add FPNO-21 to the device configuration.

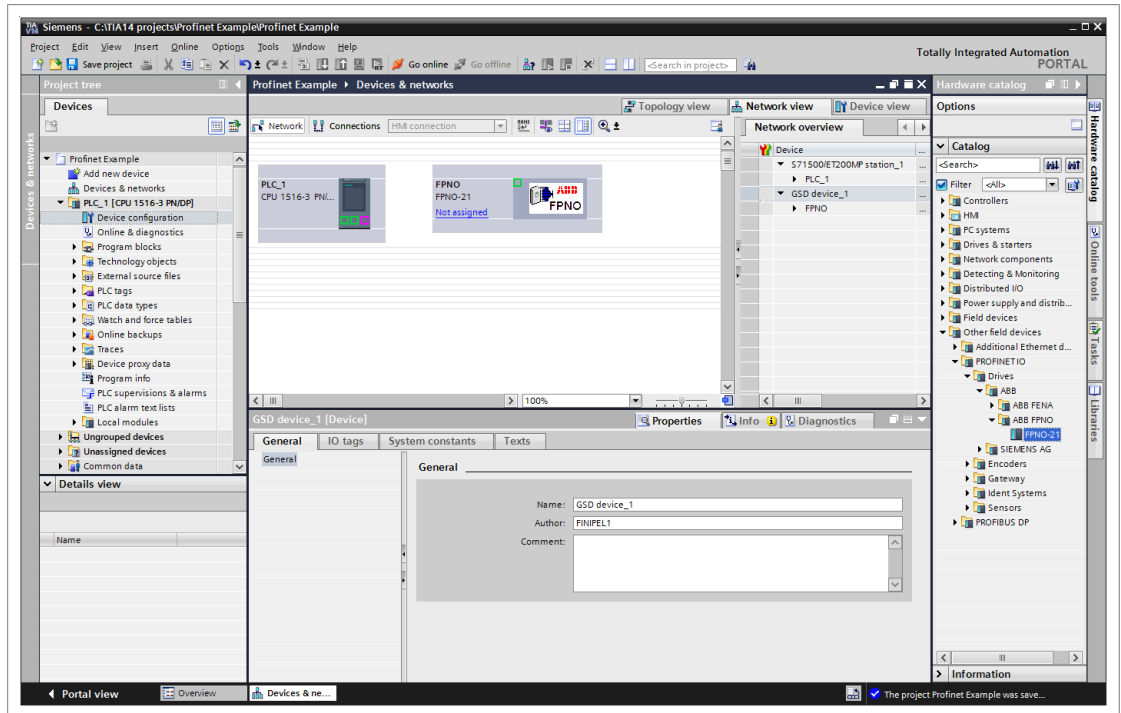

6. Open the FPNO-21 device view and add the desired telegram to slot 1.

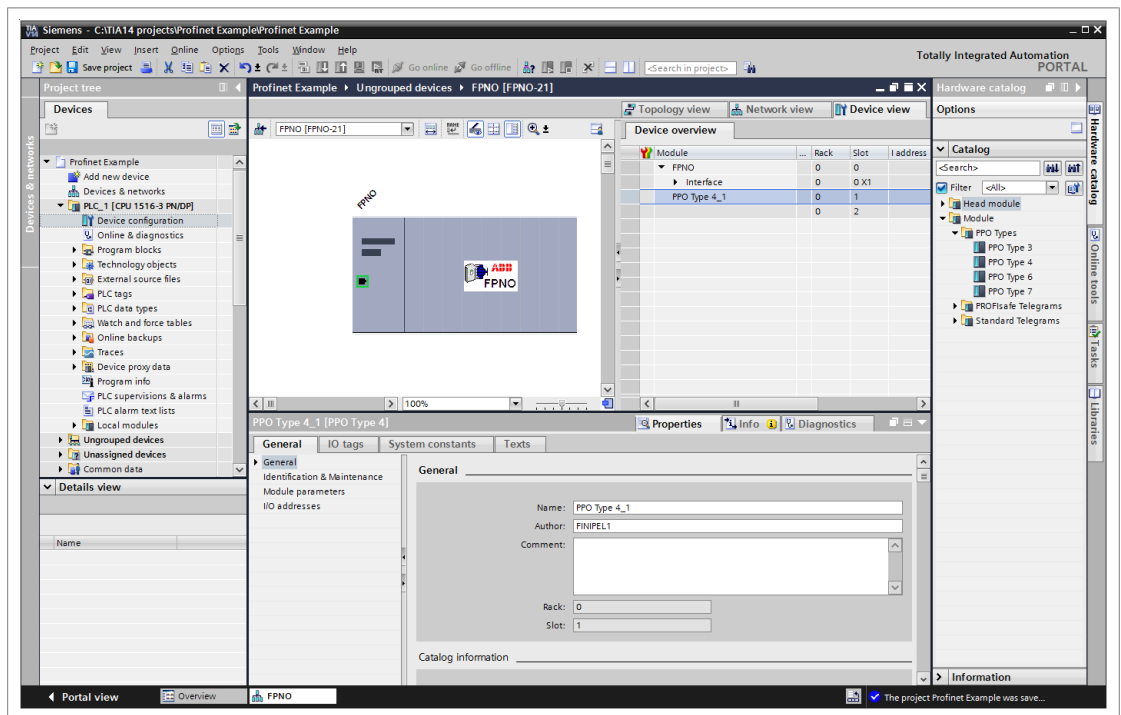

7. Assign FPNO-21 to the PROFINET controller.

58 PROFINET IO – Start-up

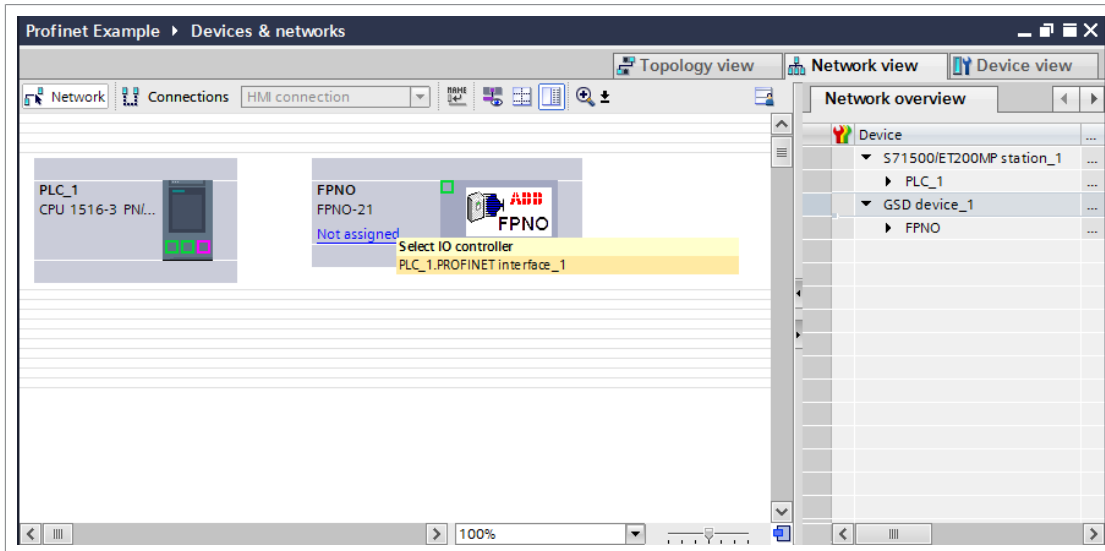

8. Select the Properties tab > General tab > Ethernet addresses submenu, and set the PLC IP address.

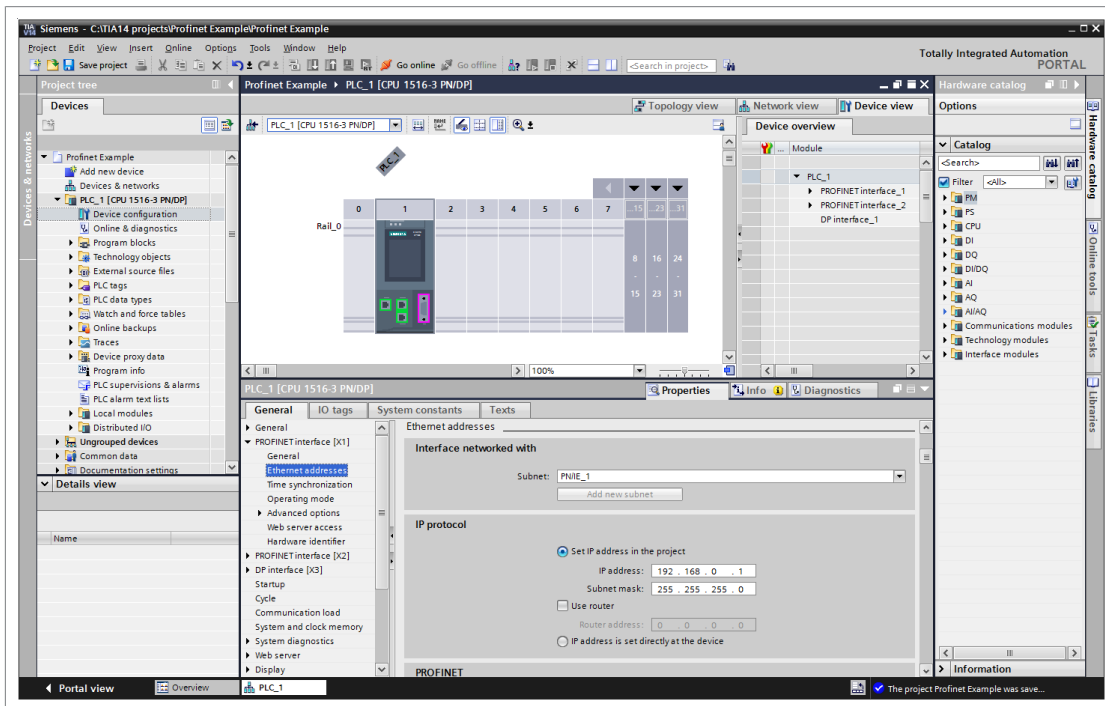

9. In the FPNO-21 properties, Ethernet addresses submenu, set the FPNO-21 IP address and PROFINET device name. Device name is used as identification. After successful identification, the PLC sets an IP address for the FPNO-21 module.

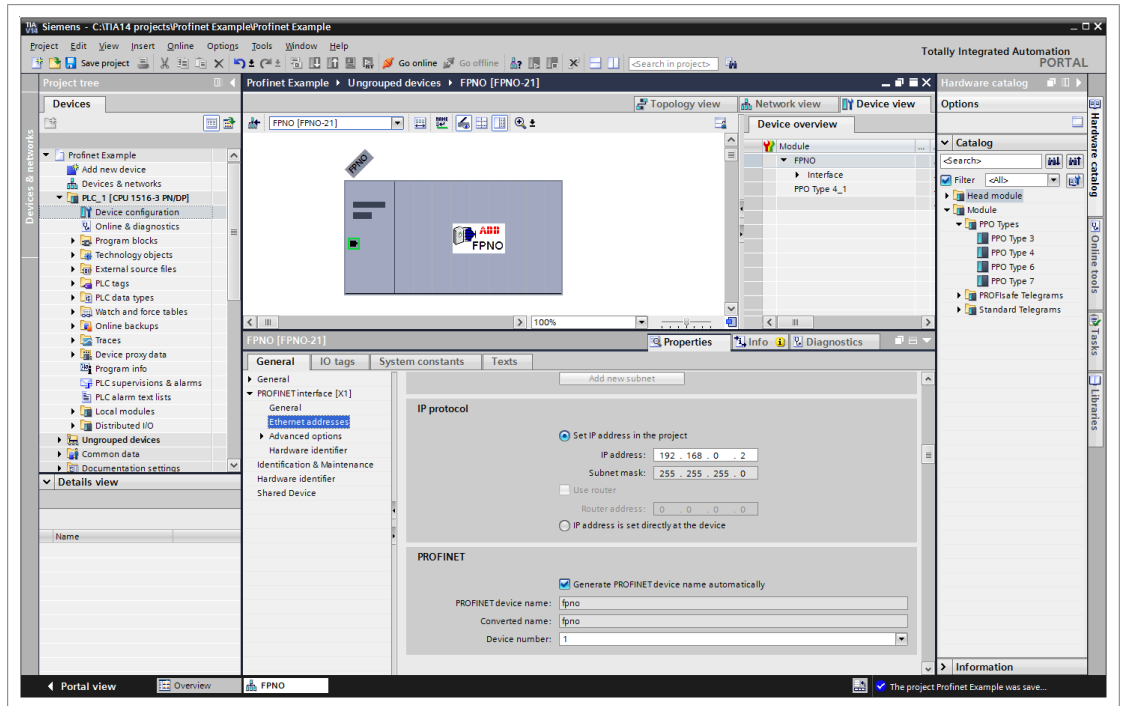

10. Add the new function block ABB_Drive.

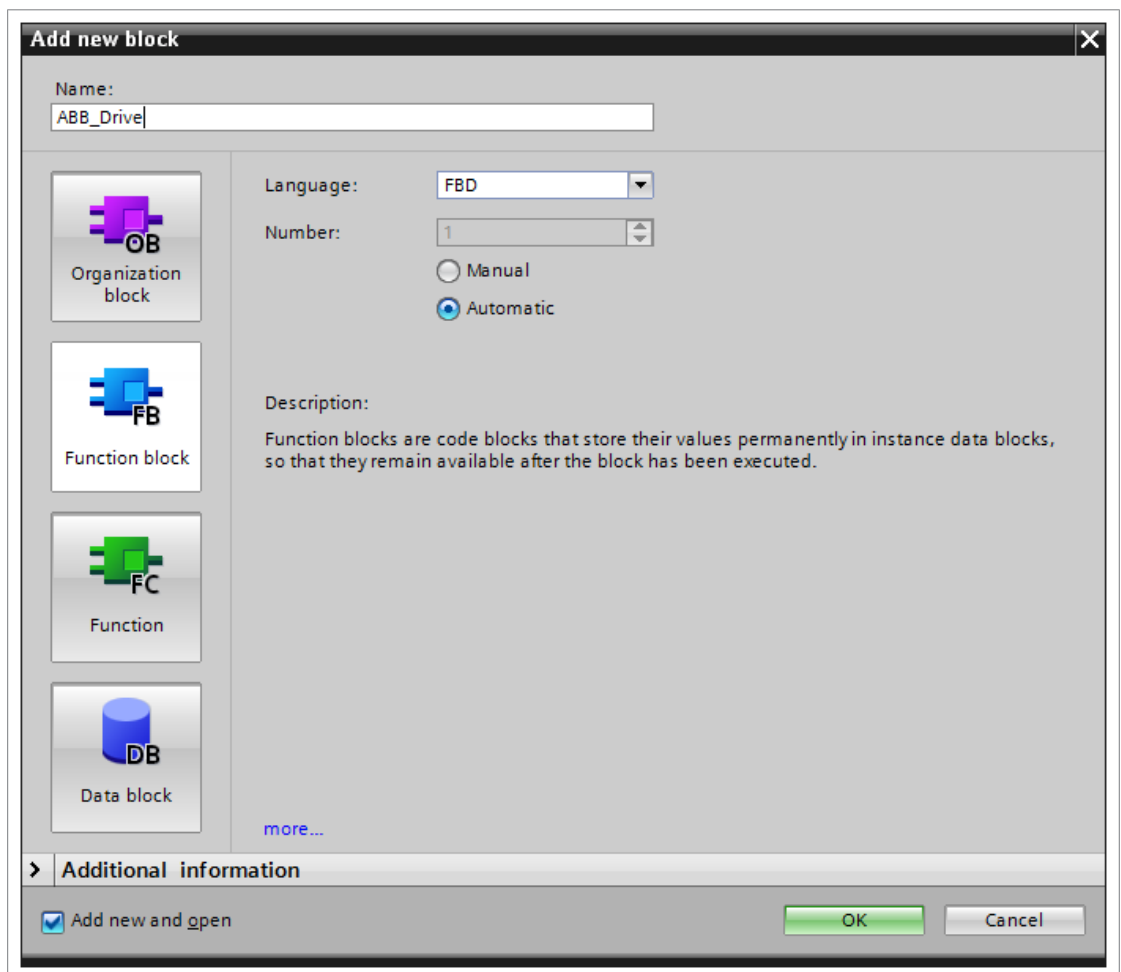

11. Add variables to ABB_Drive FB.

60 PROFINET IO – Start-up

The screenshot shows the configuration of the ABB_Drive data block. The table below represents the data shown in the software interface.

	Name	Data type	Default value	Retain	Accessible f...	Writa...	Visible in ...	Setpoint	Su...
1	Input								
2	Drive PPO HW ADDR FB	HW_SUBMODULE	0	Non-retain	<input checked="" type="checkbox"/>	<input checked="" type="checkbox"/>	<input checked="" type="checkbox"/>	<input type="checkbox"/>	
3	Output								
4	<Add new>								
5	InOut								
6	<Add new>								
7	Static								
8	PZD read error	Word	16#0	Non-retain	<input checked="" type="checkbox"/>	<input checked="" type="checkbox"/>	<input checked="" type="checkbox"/>	<input type="checkbox"/>	
9	PZD write error	Word	16#0	Non-retain	<input checked="" type="checkbox"/>	<input checked="" type="checkbox"/>	<input checked="" type="checkbox"/>	<input type="checkbox"/>	
10	PPO OUT	Struct		Non-retain	<input checked="" type="checkbox"/>	<input checked="" type="checkbox"/>	<input checked="" type="checkbox"/>	<input type="checkbox"/>	
11	PZD OUT_1	Word	16#0	Non-retain	<input checked="" type="checkbox"/>	<input checked="" type="checkbox"/>	<input checked="" type="checkbox"/>	<input type="checkbox"/>	
12	PZD OUT_2	Word	16#0	Non-retain	<input checked="" type="checkbox"/>	<input checked="" type="checkbox"/>	<input checked="" type="checkbox"/>	<input type="checkbox"/>	
13	PZD OUT_3	Word	16#0	Non-retain	<input checked="" type="checkbox"/>	<input checked="" type="checkbox"/>	<input checked="" type="checkbox"/>	<input type="checkbox"/>	
14	PZD OUT_4	Word	16#0	Non-retain	<input checked="" type="checkbox"/>	<input checked="" type="checkbox"/>	<input checked="" type="checkbox"/>	<input type="checkbox"/>	
15	PZD OUT_5	Word	16#0	Non-retain	<input checked="" type="checkbox"/>	<input checked="" type="checkbox"/>	<input checked="" type="checkbox"/>	<input type="checkbox"/>	
16	PZD OUT_6	Word	16#0	Non-retain	<input checked="" type="checkbox"/>	<input checked="" type="checkbox"/>	<input checked="" type="checkbox"/>	<input type="checkbox"/>	
17	PPO IN	Struct		Non-retain	<input checked="" type="checkbox"/>	<input checked="" type="checkbox"/>	<input checked="" type="checkbox"/>	<input type="checkbox"/>	
18	PPO IN_1	Word	16#0	Non-retain	<input checked="" type="checkbox"/>	<input checked="" type="checkbox"/>	<input checked="" type="checkbox"/>	<input type="checkbox"/>	
19	PPO IN_2	Word	16#0	Non-retain	<input checked="" type="checkbox"/>	<input checked="" type="checkbox"/>	<input checked="" type="checkbox"/>	<input type="checkbox"/>	
20	PPO IN_3	Word	16#0	Non-retain	<input checked="" type="checkbox"/>	<input checked="" type="checkbox"/>	<input checked="" type="checkbox"/>	<input type="checkbox"/>	
21	PPO IN_4	Word	16#0	Non-retain	<input checked="" type="checkbox"/>	<input checked="" type="checkbox"/>	<input checked="" type="checkbox"/>	<input type="checkbox"/>	
22	PPO IN_5	Word	16#0	Non-retain	<input checked="" type="checkbox"/>	<input checked="" type="checkbox"/>	<input checked="" type="checkbox"/>	<input type="checkbox"/>	
23	PPO IN_6	Word	16#0	Non-retain	<input checked="" type="checkbox"/>	<input checked="" type="checkbox"/>	<input checked="" type="checkbox"/>	<input type="checkbox"/>	
24	<Add new>								
25	<Add new>								
26	Temp								
27	<Add new>								
28	Constant								
29	<Add new>								

12. Add ABB_Drive to OB1. Assign a new instance Data Block for ABB_Drive FB.

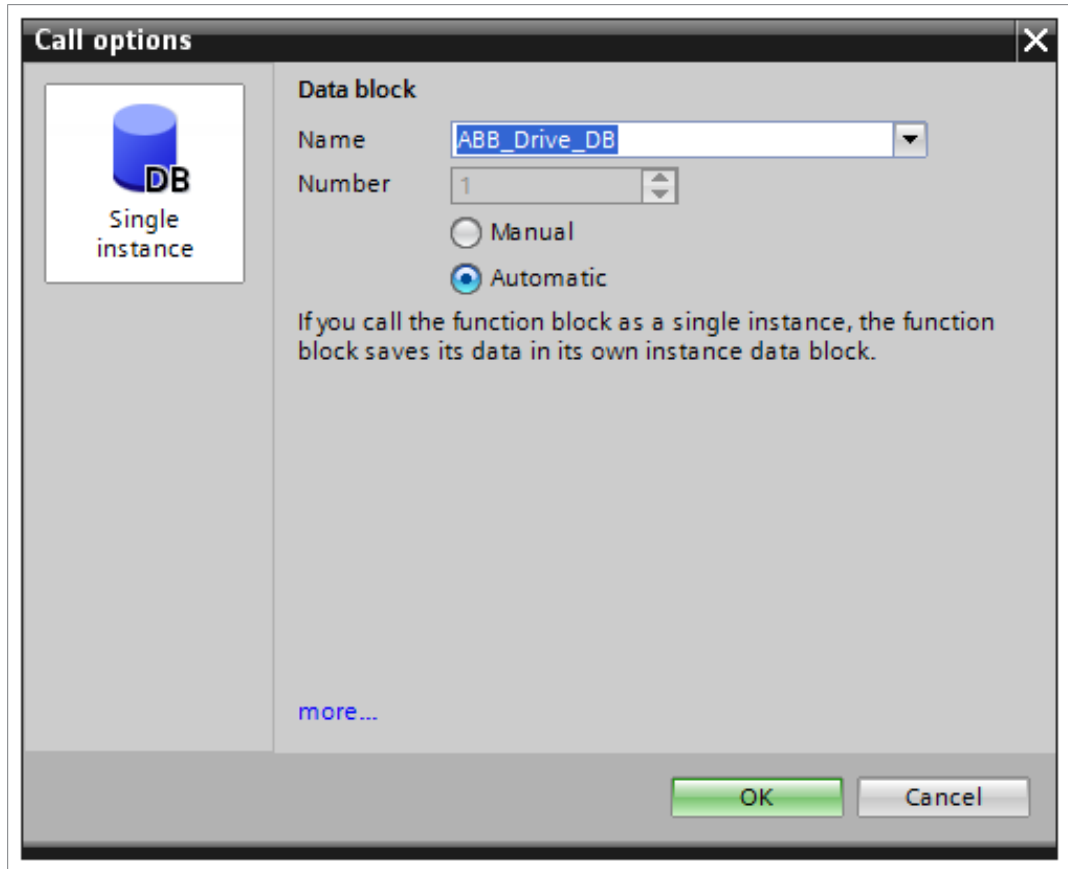

13. Add the FPNO-21 PPO HW address to Drive PPO HW ADDR FB input.

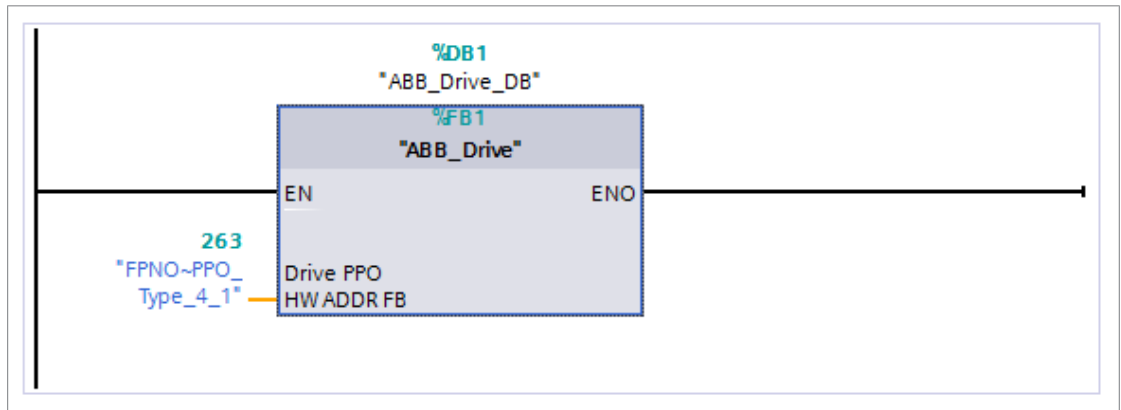

14. Add blocks DPRD_DAT and DPWR_DAT to ABB_Drive FB. Map the inputs and outputs.

62 PROFINET IO – Start-up

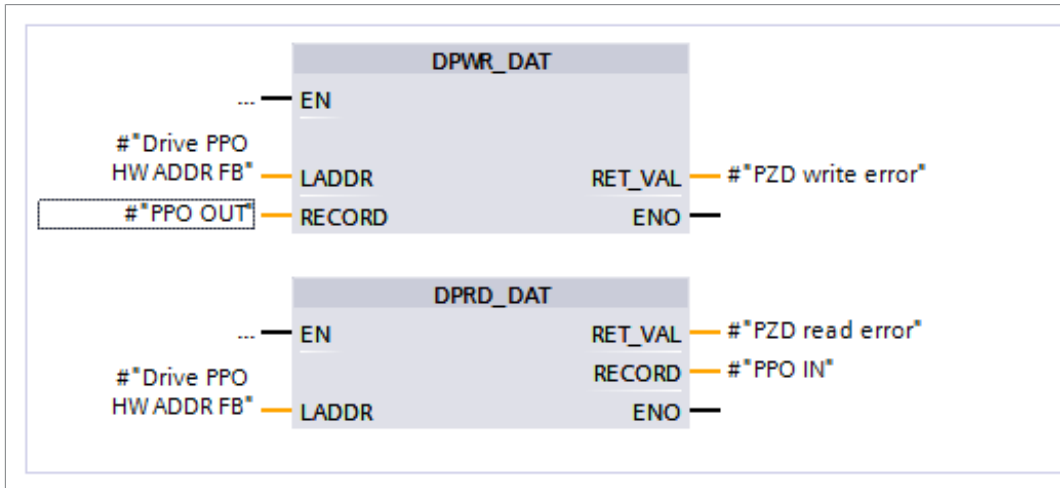

15. Save and download the project to the PLC.

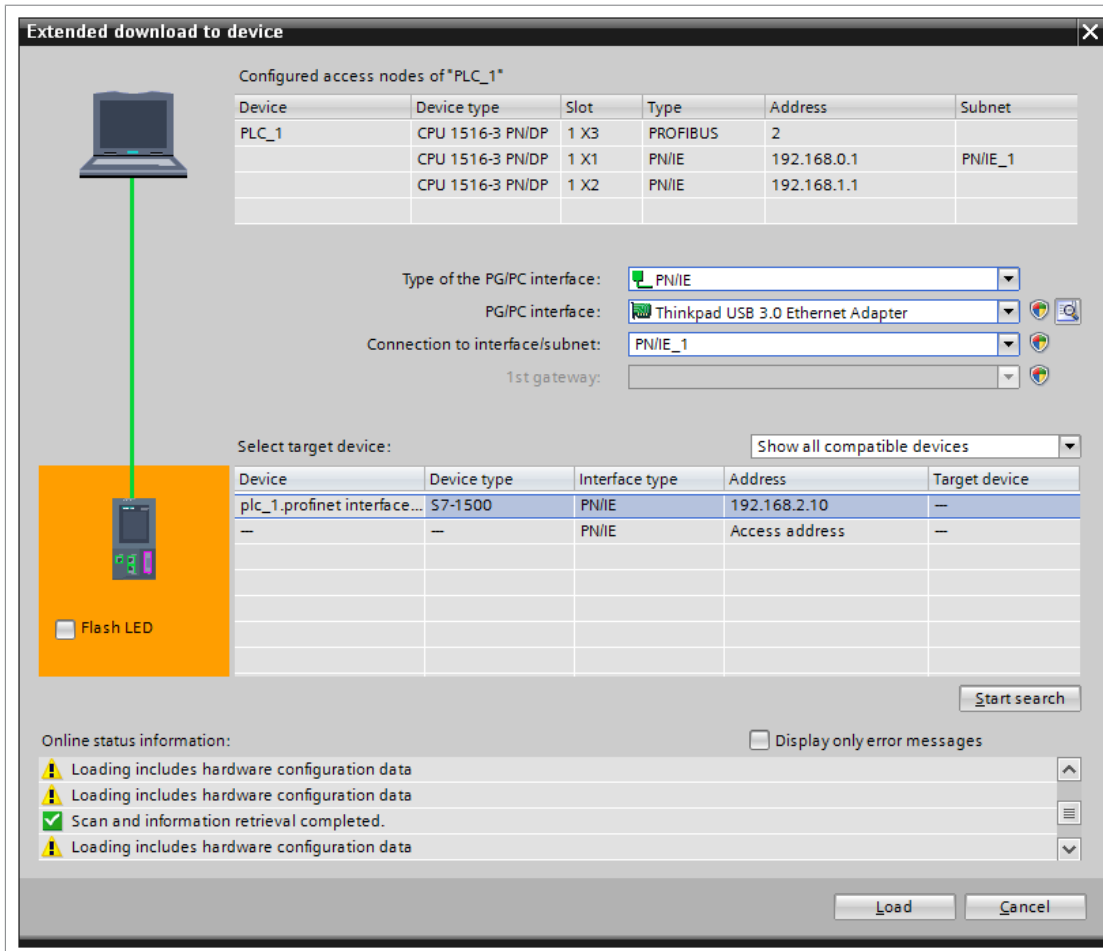

16. In the device configuration, right-click the FPNO-21 icon and select Assign device name.

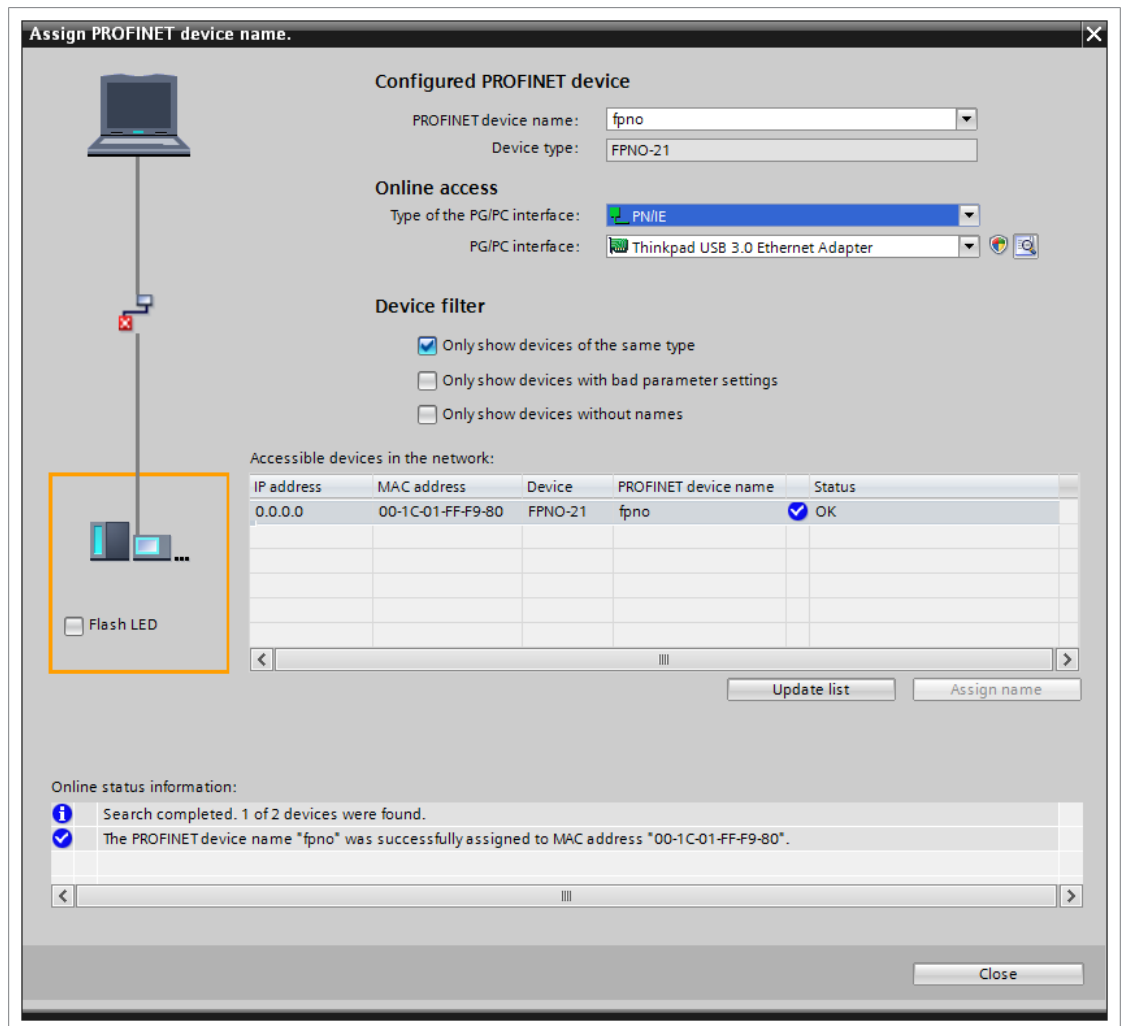

17. Values can now be monitored when online.

64 PROFINET IO – Start-up

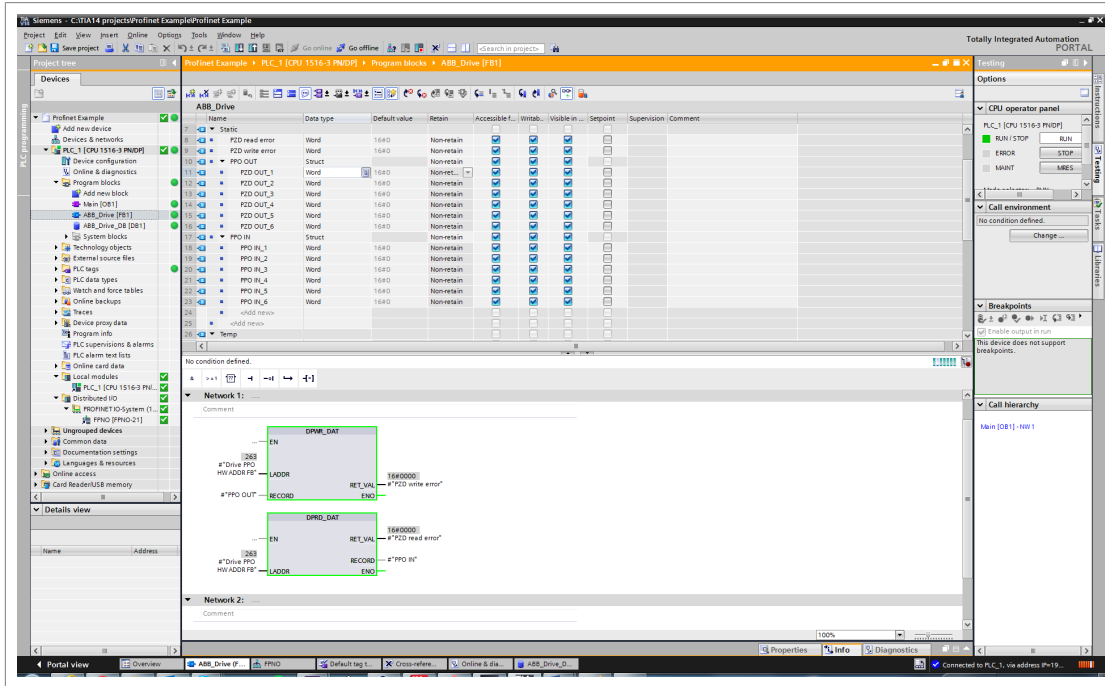

18. If the values need to be forced, add the FPNO-21 addresses to the tag table, and add the tag table variables to the force table.

Name	Address	Display format	Monitor value	Monitor with trig...	Force value	F	C...
"ABB_Drive_DB"."PPO IN"."PPO IN_1"		Hex	16#1231	Permanent		<input type="checkbox"/>	
"ABB_Drive_DB"."PPO IN"."PPO IN_2"		Hex	16#0000	Permanent		<input type="checkbox"/>	
"ABB_Drive_DB"."PPO IN"."PPO IN_3"		Hex	16#0000	Permanent		<input type="checkbox"/>	
"ABB_Drive_DB"."PPO IN"."PPO IN_4"		Hex	16#0000	Permanent		<input type="checkbox"/>	
"ABB_Drive_DB"."PPO IN"."PPO IN_5"		Hex	16#0000	Permanent		<input type="checkbox"/>	
"ABB_Drive_DB"."PPO IN"."PPO IN_6"		Hex	16#0000	Permanent		<input type="checkbox"/>	
"ABB_Drive_DB"."PPO OUT"."PZD OUT_1"		Hex	16#0000	Permanent		<input type="checkbox"/>	
"ABB_Drive_DB"."PPO OUT"."PZD OUT_2"		Hex	16#0000	Permanent		<input type="checkbox"/>	
"ABB_Drive_DB"."PPO OUT"."PZD OUT_3"		Hex	16#0000	Permanent		<input type="checkbox"/>	
"ABB_Drive_DB"."PPO OUT"."PZD OUT_4"		Hex	16#0000	Permanent		<input type="checkbox"/>	
"ABB_Drive_DB"."PPO OUT"."PZD OUT_5"		Hex	16#0000	Permanent		<input type="checkbox"/>	
"ABB_Drive_DB"."PPO OUT"."PZD OUT_6"		Hex	16#0000	Permanent		<input type="checkbox"/>	
"ABB_Drive_DB"."PZD read error"		Hex	16#0000	Permanent		<input type="checkbox"/>	
"ABB_Drive_DB"."PZD write error"		Hex	16#0000	Permanent		<input type="checkbox"/>	
"SW":P	%IW0:P	Hex	16#1231	Permanent		<input type="checkbox"/>	
"Act1":P	%IW2:P	DEC	0	Permanent		<input type="checkbox"/>	
"CW":P	%QW0:P	Hex	16#047E	Permanent	16#047E	<input checked="" type="checkbox"/>	
"Ref1":P	%QW2:P	DEC	500	Permanent	500	<input checked="" type="checkbox"/>	
<Add new>						<input type="checkbox"/>	

Media Redundancy Protocol (MRP)

The Media Redundancy Protocol (MRP) network uses a ring topology that includes multiple nodes as shown in the connection diagram. One of the nodes has the Media Redundancy Manager (MRM) role and the nodes with FPNO-21 module(s) have the role of Media Redundancy Clients (MRC). Each node, MRM or MRC, has a pair of ports to connect to the ring.

For the FPNO-21 module, the link speed of both ports is 100 Mbit/s, full-duplex.

Note: The maximum number of nodes in the ring is 50.

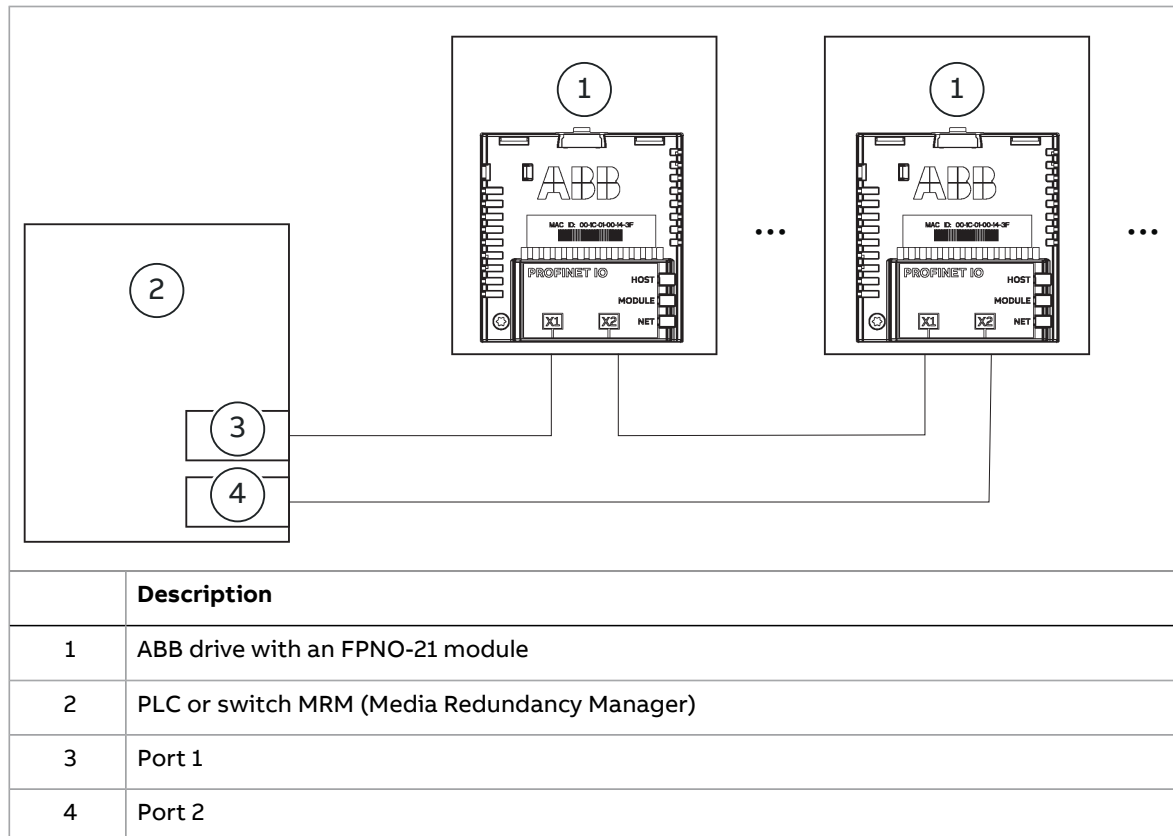

■ Configuring Media Redundancy Protocol (MRP) with Siemens PLC

You can configure MRP for Siemens PLC with SIMATIC S7 after you set the basic configuration. For instructions on the basic configuration, refer to [Configuring a Siemens SIMATIC S7 PLC \(page 47\)](#).

1. Double-click PN-IO in the station window.

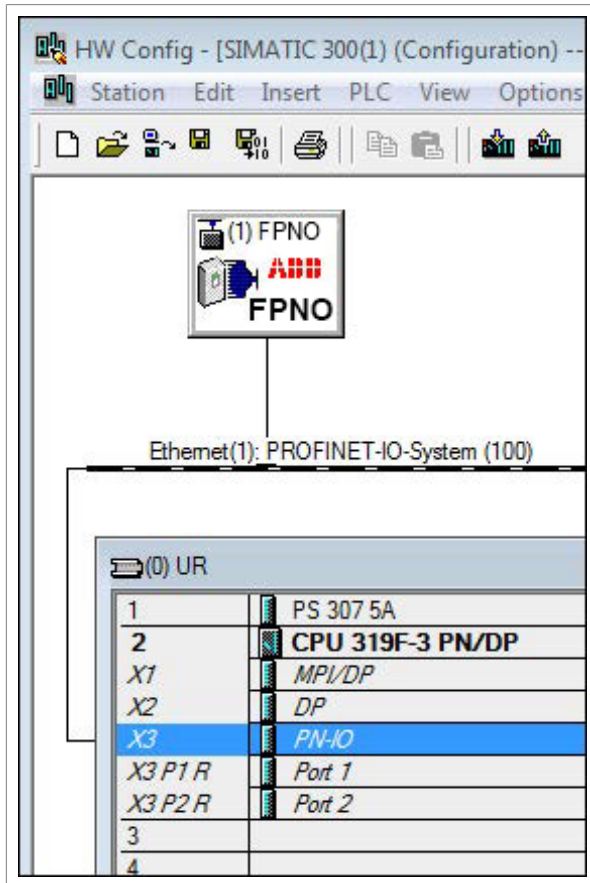

PN-IO properties window is displayed.

2. In the Properties PN-IO window, select Media Redundancy tab.

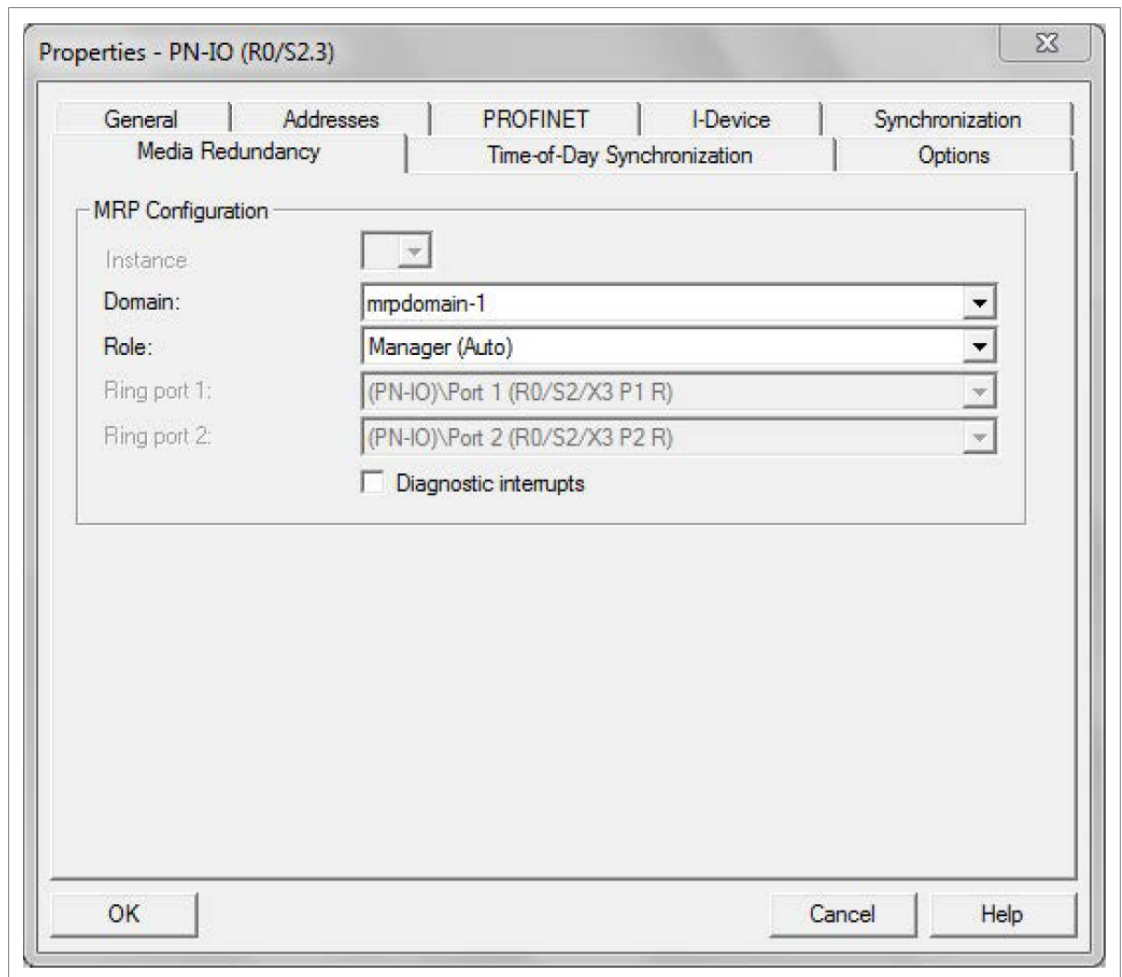

3. From the Role drop-down list, select the Manager (Auto) role for the PLC and then click OK.
4. In the master station window, click FPNO and then double-click Interface.

68 PROFINET IO – Start-up

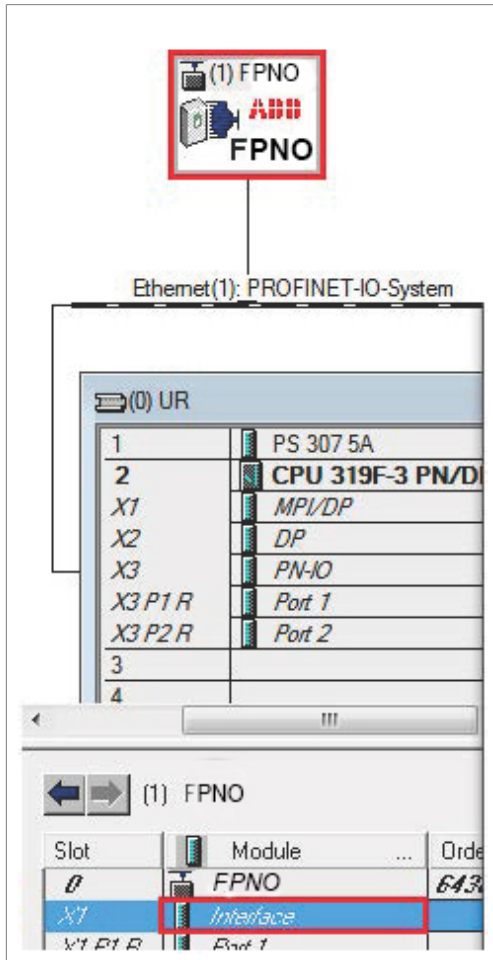

The Properties-Interface window is displayed.

5. In the Properties-Interface window, select Media Redundancy tab.

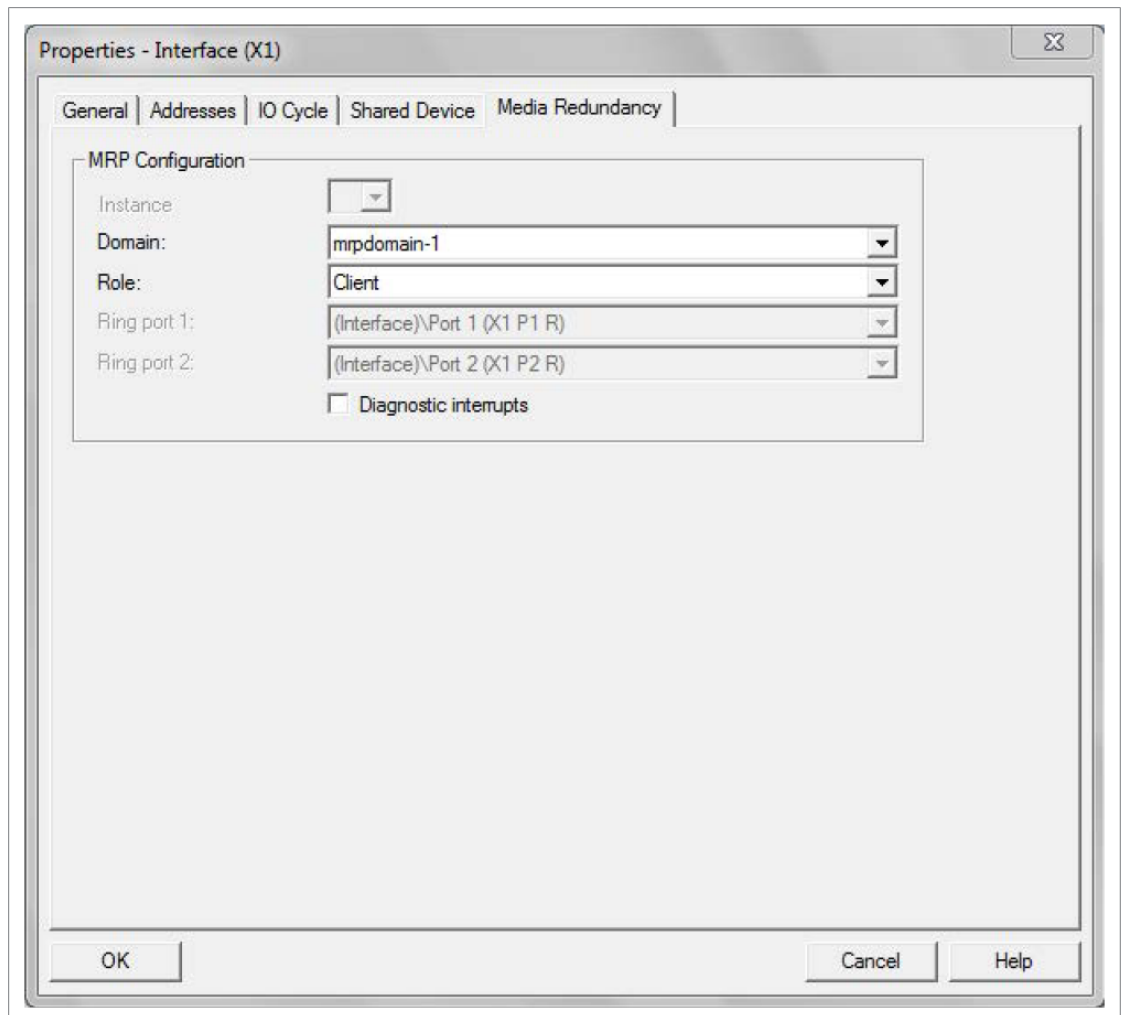

6. From the Role drop-down list, select the Client role for the FPNO-21 module.
7. In the Properties-Interface window, select IO Cycle and set the watchdog time. A recommended value for the watchdog time is 200 ms. Make sure that the connection is maintained during the ring break.

70 PROFINET IO – Start-up

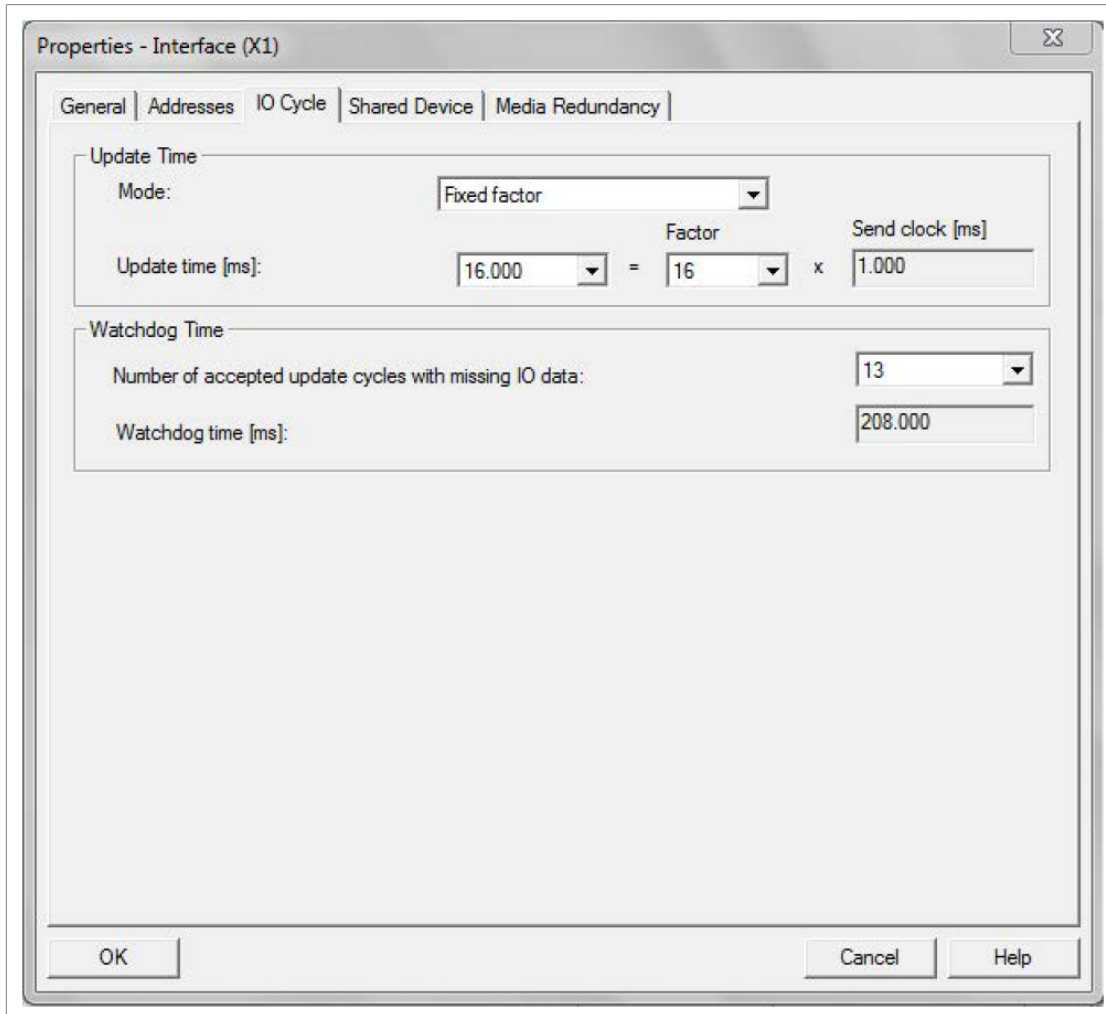

8. In the master station window, right-click on PROFINET IO System and select PROFINET IO Domain Management.

The configured devices (PN-IO and FPNO) are shown in the Domain management window.

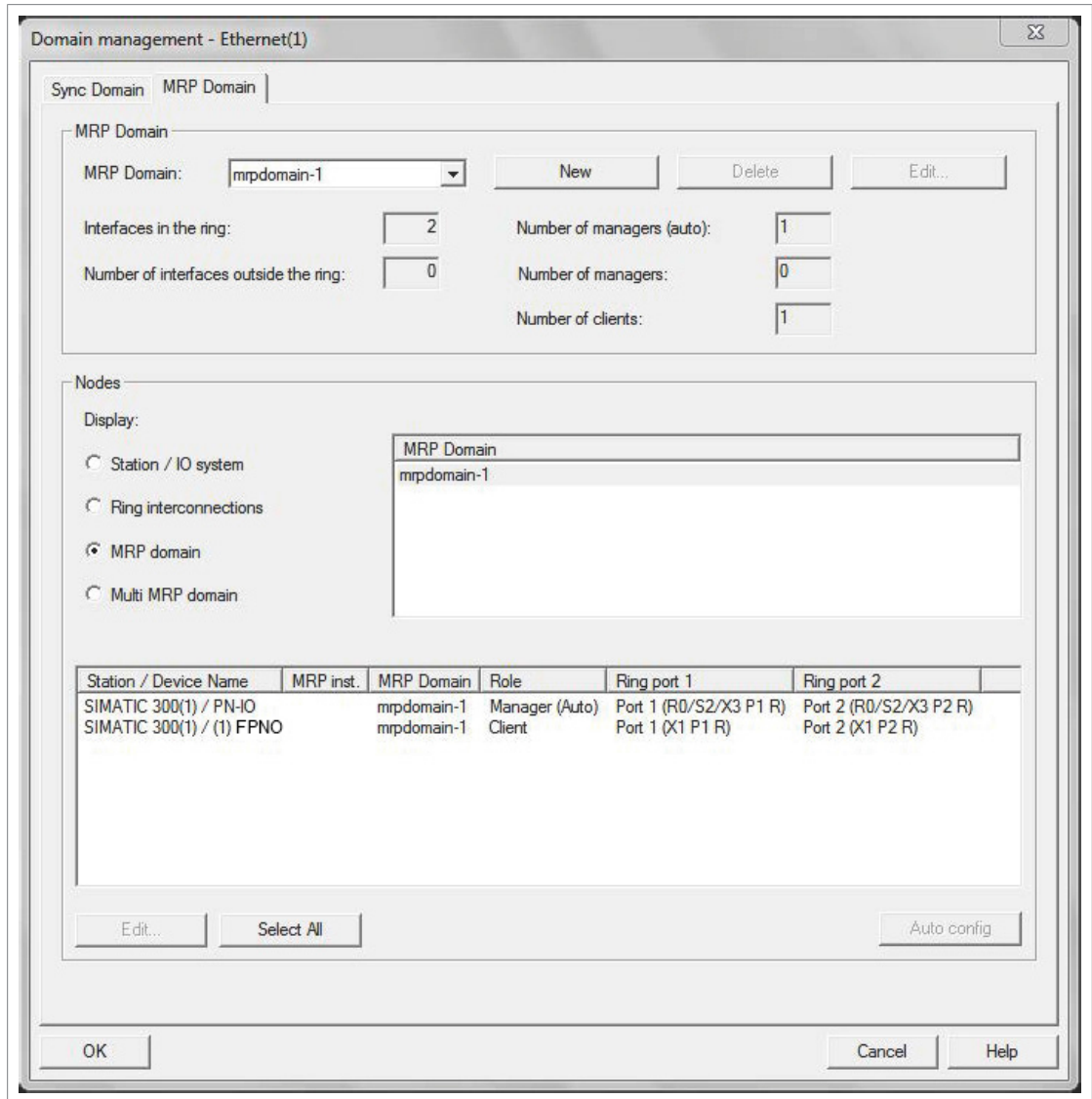

■ **Configuring Media Redundancy Protocol (MRP) with TIA14**

You can configure MRP for Siemens PLC with TIA14 after you set the basic configuration. For instructions of the basic configuration, refer to [Configuring a Siemens PLC with TIA14 \(page 56\)](#).

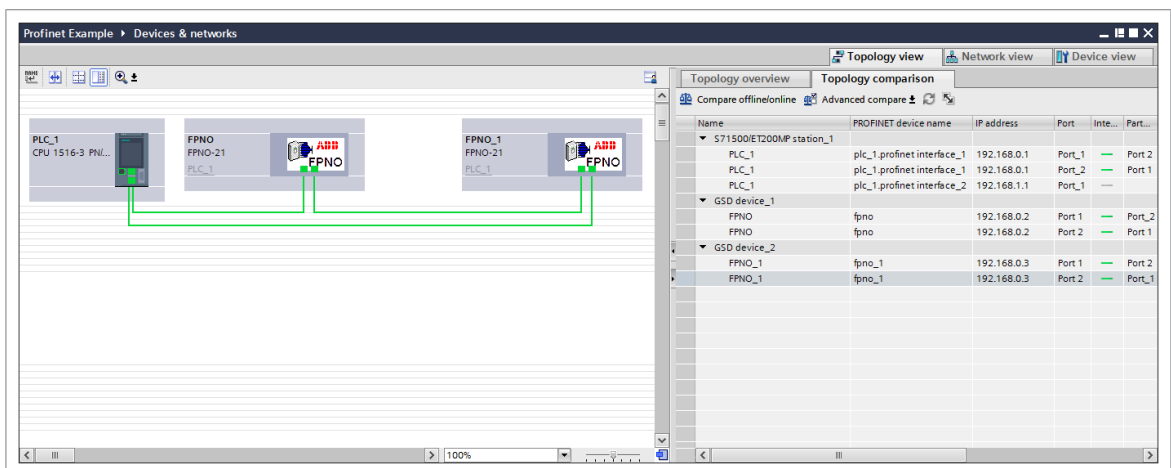

To configure an MRP with TIA portal:

72 PROFINET IO – Start-up

1. In TIA portal Device overview, expand the PLC and select the desired PROFINET interface.

The PROFINET interface view is displayed.

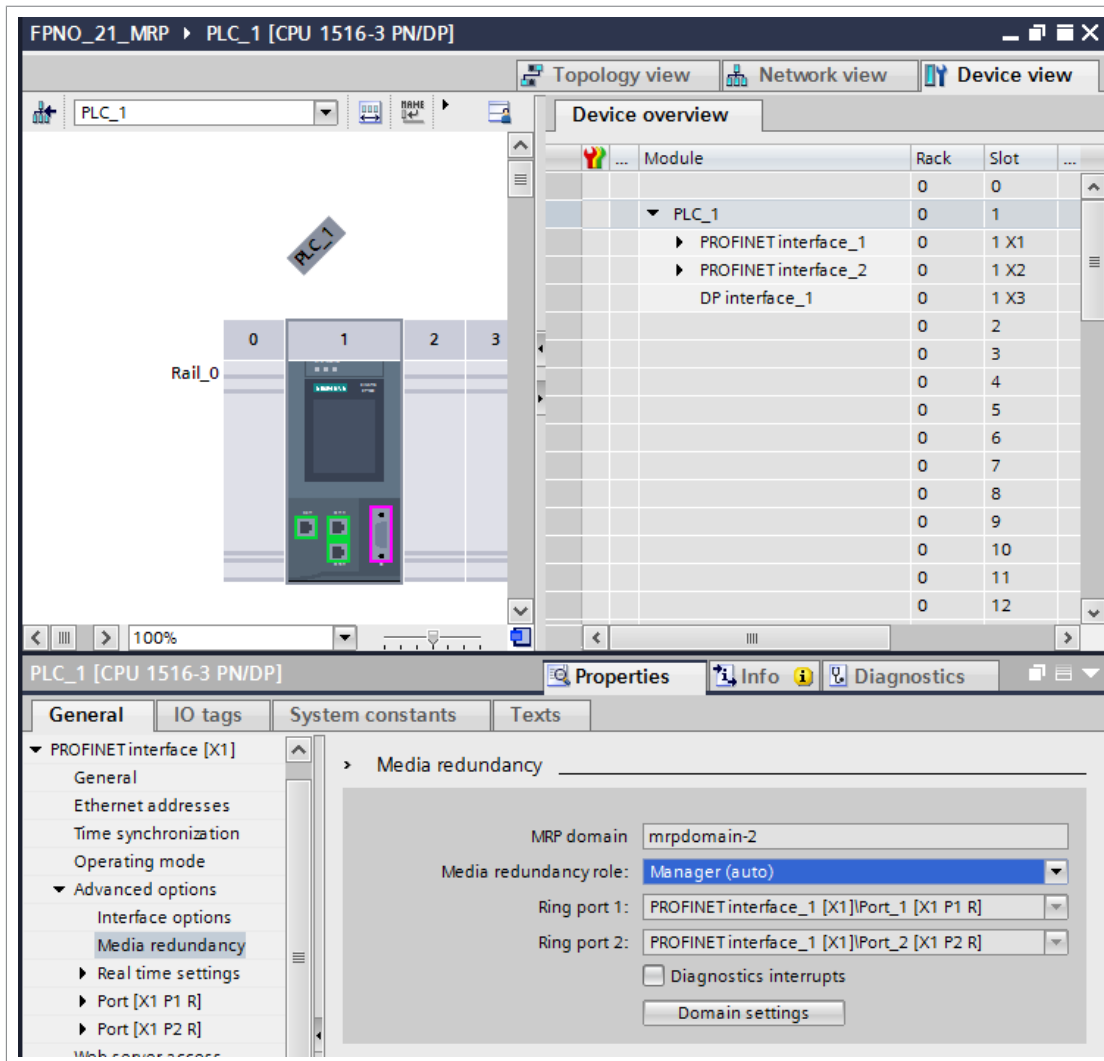

2. In PROFINET interface view, click the General tab and select Media Redundancy and then select the Manager (auto) role for the PLC.
3. In the Device overview, expand FPNO-21 and select Interface.

The PROFINET interface view is displayed.

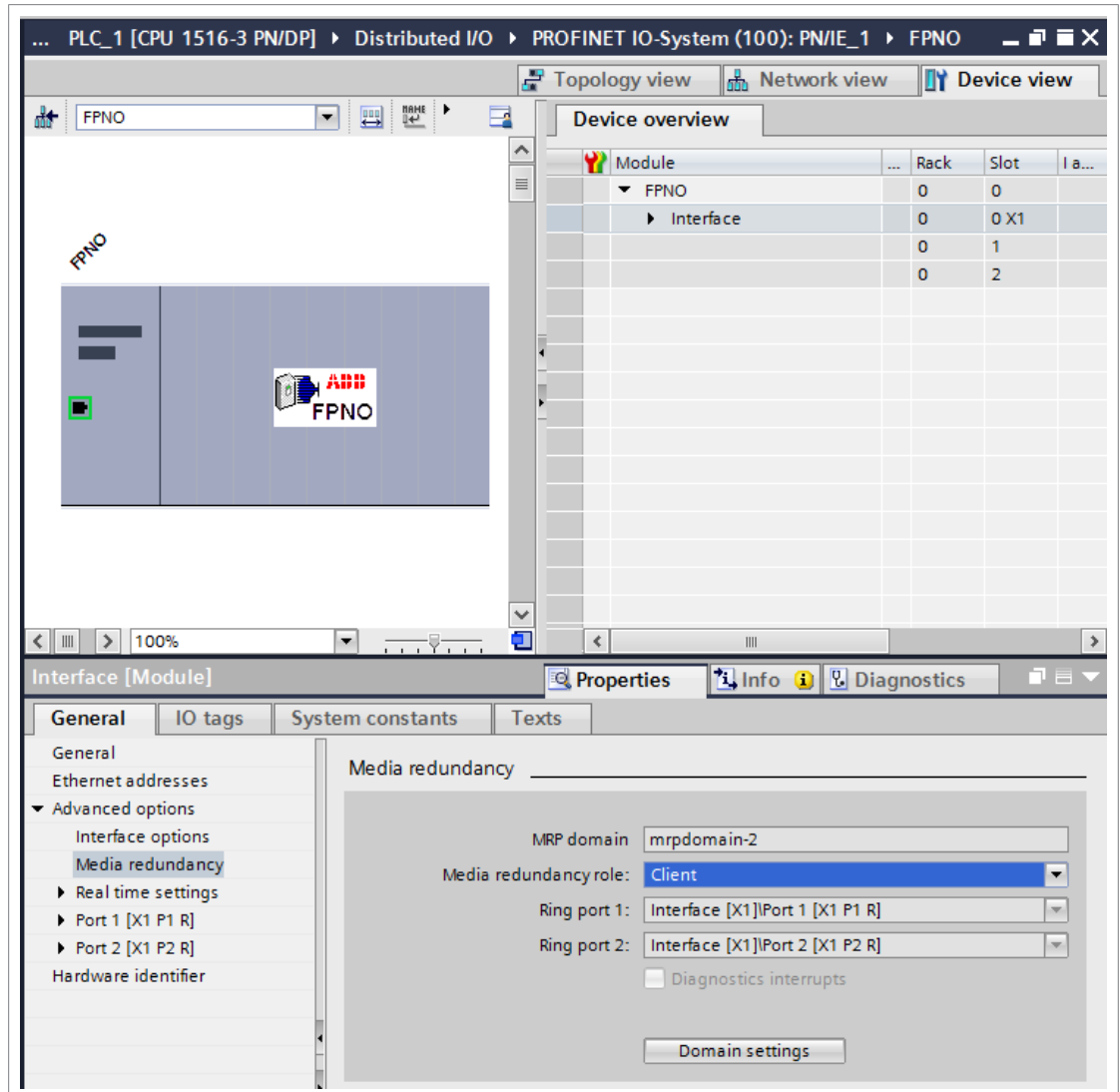

4. In PROFINET interface view, click the General tab and select Media Redundancy and then select the Client role for the FPNO-21 module.
5. In the General tab, select IO cycle and set the watchdog time.

The recommended value for the watchdog time is 200 ms. Make sure that the connection is maintained during the ring break.

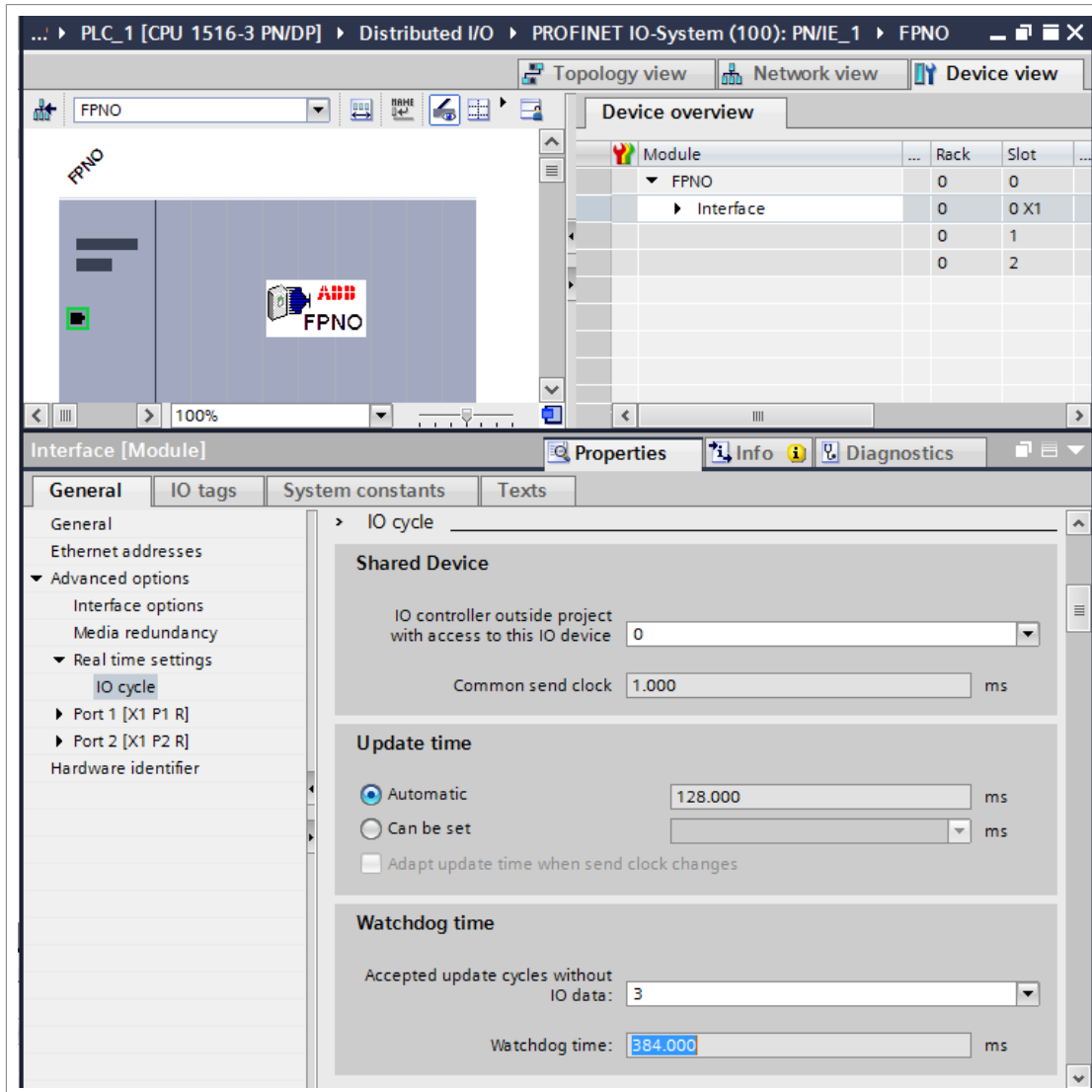

For MRP domain management, go to the Media Redundancy view and click the Domain settings button.

Shared Device

With the Shared Device enable option, you can access one drive from two controllers through one FPNO-21 module.

For example, one PLC controls the drive and the other Safety PLC is for safety communication. The PROFINET drive control and PROFIsafe can be used by separate PLCs.

■ Configuring Shared Device for ABB PLC with Automation Builder

Configuring the drive control PLC

1. Select the PPO telegram to use on slot 1. Leave slot 2 empty.
2. Define the PROFINET station name and the IP address based on the network.

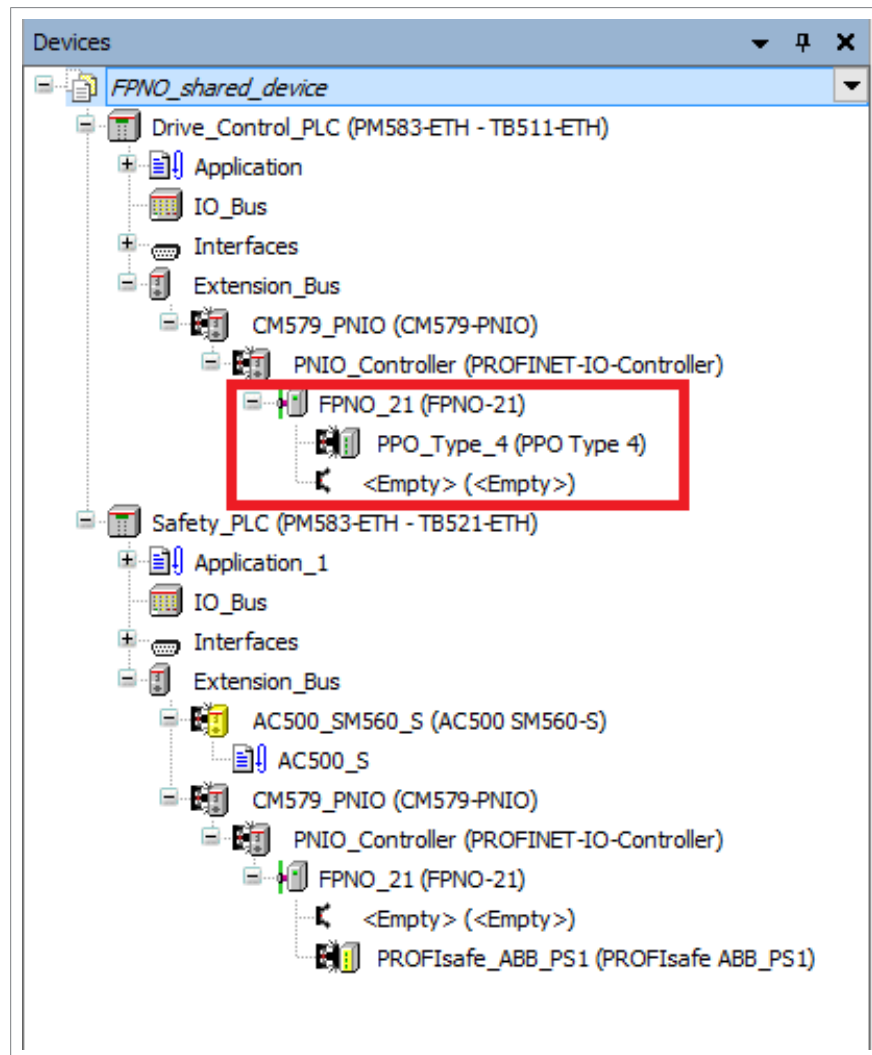

Configuring the safety PLC

1. Select the safety telegram to use on slot 2. Leave slot 1 empty.

76 PROFINET IO – Start-up

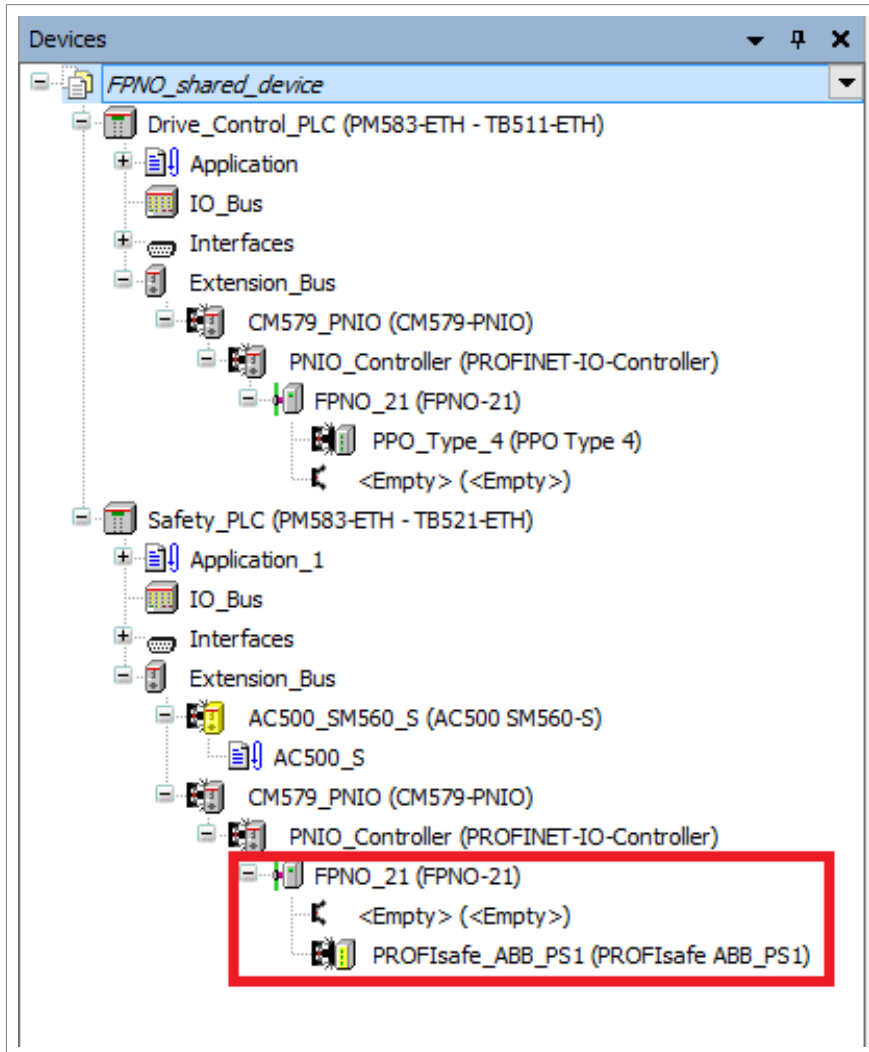

2. Use the same PROFINET station name as in the drive control PLC configuration.
3. On the Options tab, tick the Shared Device check box.

The screenshot shows the 'FPNO_21' configuration window. The 'Options' tab is selected. The 'Shared Device' checkbox is checked. The 'Port Data' section shows configuration for Port-001 and Port-002. Port-001 is configured with Peer-Station/Port 'controller', Cable Length '< 10 m', and MAUType '100BaseTXFD (Copper)'. Port-002 is currently empty.

Port	Peer-Station/Port	Cable Length	MAUType
Port-001	controller	< 10 m	100BaseTXFD (Copper)
Port-002			

■ **Configuring Shared Device for Siemens PLC with TIA portal**

Configuring the drive control PLC

1. Select the PPO telegram to use on slot 1. Leave slot 2 empty.
2. Define the PROFINET station name and IP address.

Configuring the safety PLC

1. Select FPNO-21 in the Device view.
2. Select the safety telegram to use on slot 2. Leave slot 1 empty.
3. Use the same PROFINET station name as in the drive control PLC configuration.
4. From the Shared Device tab, select the access rights to the PROFIsafe slot for the Safety PLC.

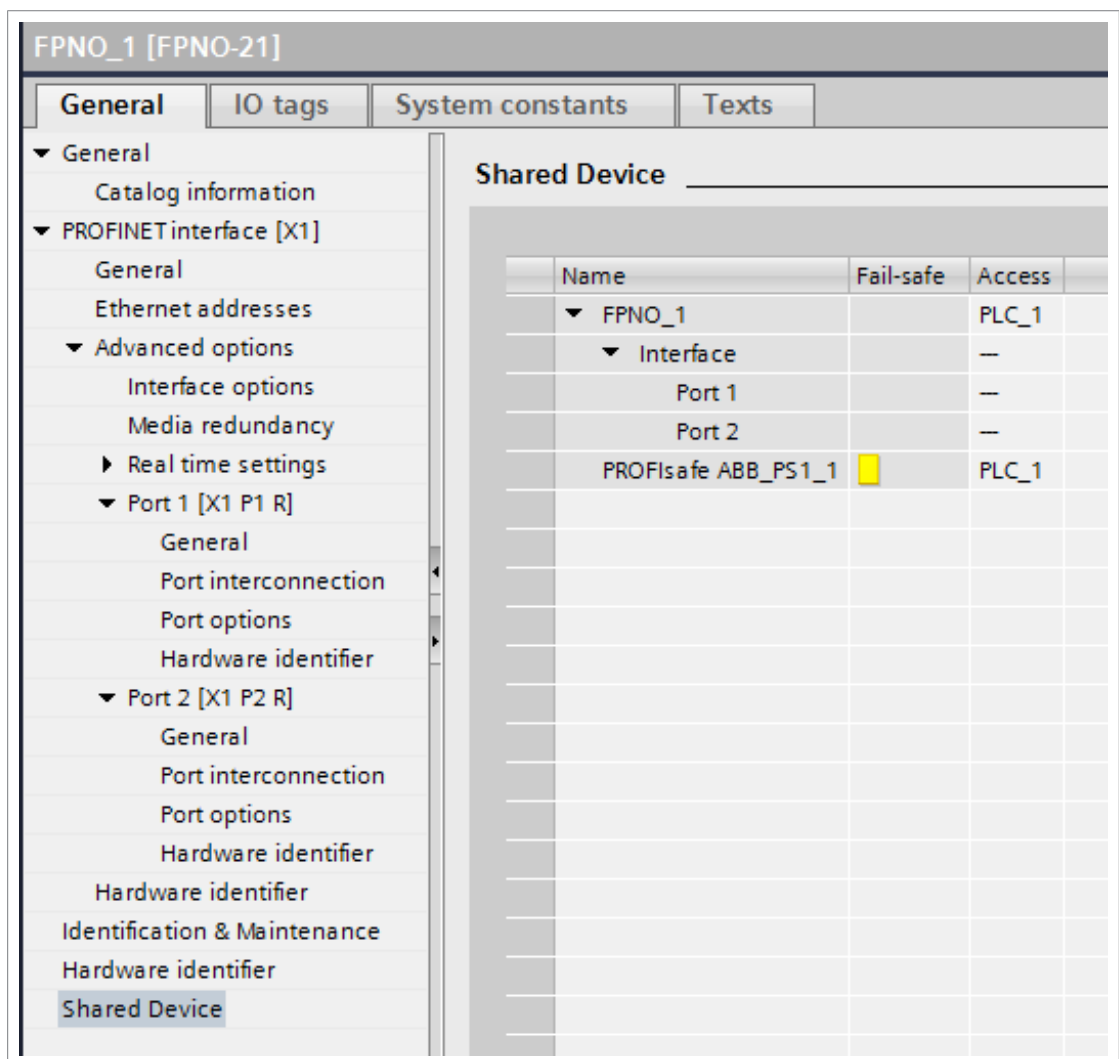

S2 system redundancy

System redundancy can increase system availability by making it more fault tolerant. In S2 system redundancy there are redundant PROFINET controllers in the network. In case of a failure in the primary controller connection a backup controller detects the failure and takes control of the devices in the network. S2 system redundancy is topology independent. You can combine the S2 system redundancy with the ring topology (MRP).

Note that both primary and backup controllers establish their own cyclic PROFINET connections to the devices and give double the amount of cyclic communication data. Take this into account in the network dimensioning.

FPNO-21 supports S2 system redundancy from firmware version 1.10 onwards with GSDML-V2.4-ABB-FPNO-20201118 and later.

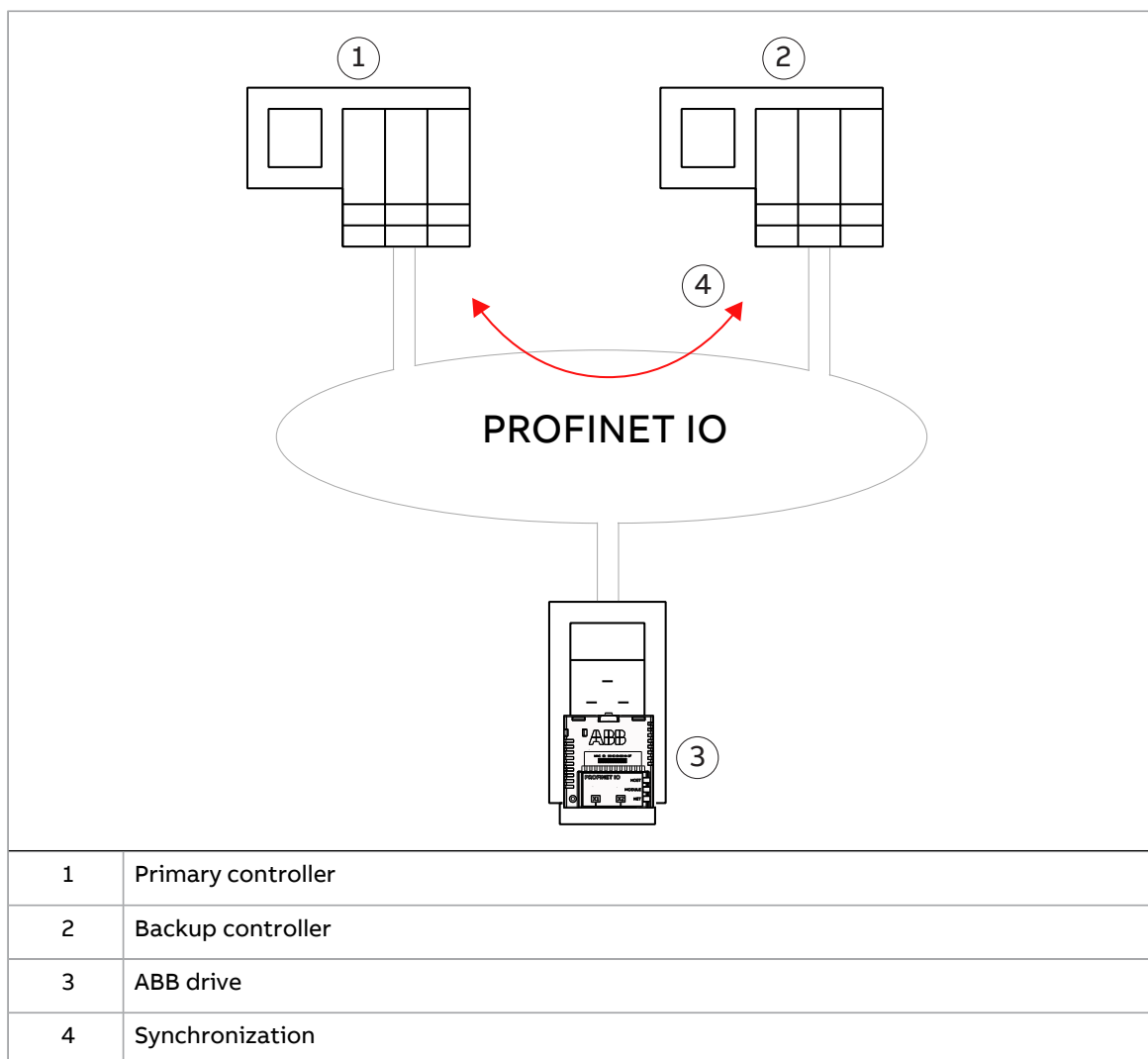



PROFINET IO – Communication profiles

Contents of this chapter

This chapter describes the communication profiles that are used in the communication between the PROFINET IO master, the adapter module and the drive.

Communication profiles

Communication profiles are ways of conveying control commands (Control word, Status word, references and actual values) between the master station and the drive.

With the FPNO-21 module, the PROFINET network can use either the PROFIdrive v4.2, legacy PROFIdrive (referred to as PROFIdrive from here on) or the ABB Drives profile. All are converted to the native profile (for example, DCU or FBA) by the adapter module. In addition, two Transparent modes (for 16-bit and 32-bit words) are available. With the Transparent modes, no data conversion takes place.

This figure shows the profile selection:

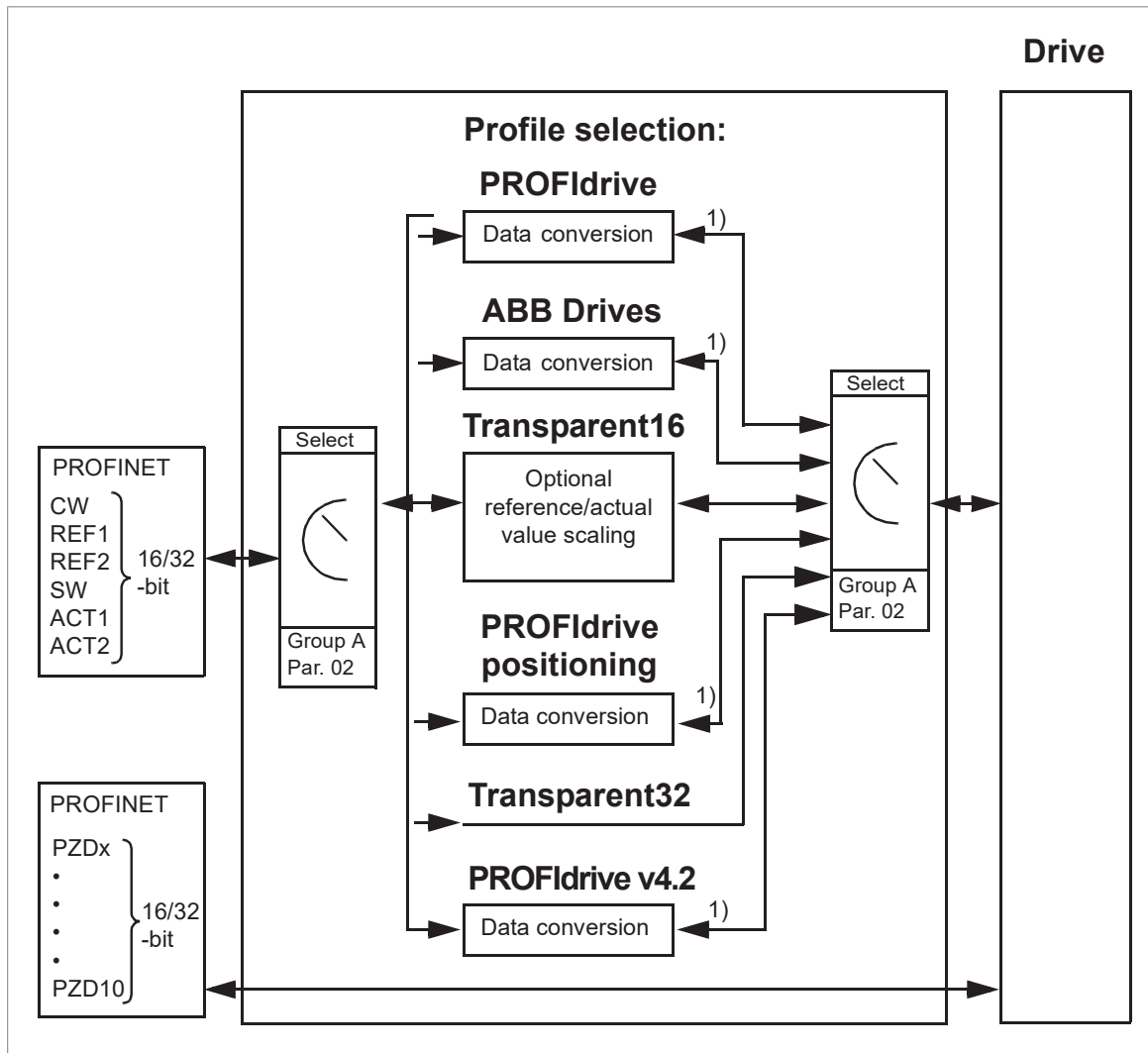

¹⁾ Native profile (for example, DCU or FBA).

Note: The diagram is applicable only when PPO messaging is used. If Standard Telegrams (ST) are used, the communication profile is selected automatically.

The sections that follow describe the Control word, the Status word, references and actual values for the PROFdrive and ABB Drives communication profiles. Refer to the drive manuals for details on the native profiles.

PROFdrive communication profile

■ Control word and Status word

The Control word (PROFdrive parameter 967) is the primary procedure to control the drive from a fieldbus system. The fieldbus master station sends it to the drive through the adapter module. The drive switches between its states according to the bit-coded instructions in the Control word and returns status information to the master in the Status word (PROFdrive parameter 968).

The contents of the Control word and the Status word are detailed below. Refer to the drive documentation for information on the drive-specific bits. For the drive states, refer to page 85. For the drive states for the positioning mode, refer to page 86.

Control word contents

The table below shows the contents of the Control word for the PROFIdrive communication profile (PROFIdrive parameter 967). The upper case boldface text refers to the states of the state machine on page 85.

Bit	Name	Value	STATE/Description	
			Speed control mode	Positioning mode
0	ON	1	Proceed to READY TO OPERATE .	
	OFF1	0	Emergency OFF, stop by the selected deceleration ramp. Proceed to OFF1 ACTIVE ; proceed further to READY TO SWITCH ON unless other interlocks (OFF2, OFF3) are active.	
1	OFF2	1	Continue operation (OFF2 inactive).	
		0	Emergency OFF, coast to stop. Proceed to OFF2 ACTIVE ; proceed further to SWITCH-ON INHIBIT .	
2	OFF3	1	Continue operation (OFF3 inactive).	
		0	Emergency stop, stop according to fastest possible deceleration mode. Proceed to OFF3 ACTIVE ; proceed further to SWITCH-ON INHIBIT .  WARNING! Make sure that the motor and driven machine can be stopped using this stop mode.	
3	OPERATION_ENABLE	1	Proceed to ENABLE OPERATION .	
		0	Inhibit operation. Proceed to OPERATION INHIBIT .	
4	ENABLE_RAMP_GENERATOR or TRAVERSING_TASK	1	Normal operation. Proceed to RAMP FUNCTION GENERATOR: ENABLE OUTPUT .	Normal operation. Do not reject the traversing task.
		0	Stop according to the selected stop type.	Reject the traversing task.
5		1	Normal operation. Proceed to RAMP FUNCTION GENERATOR: ENABLE ACCELERATION .	Normal operation. No intermediate stop.
		0	Halt ramping (Ramp Function Generator output held).	Intermediate stop
6		1	Normal operation. Proceed to OPERATING . Note: This bit is effective only if the fieldbus interface is set as the source for this signal by drive parameters.	Activate traversing task (0 → 1). This is a toggle bit; each rising edge of signal enables a traversing task or a new set point.
		0	Force Ramp Function Generator input to zero.	

Bit	Name	Value	STATE/Description	
			Speed control mode	Positioning mode
7	RESET	0 → 1	Fault reset if an active fault exists. Proceed to SWITCH-ON INHIBIT. Note: This bit is effective only if the fieldbus interface is set as the source for this signal by drive parameters.	
		0	(Continue normal operation)	
8	JOGGING_1		Jogging 1 (Not supported by all drive types)	
9	JOGGING_2		Jogging 2 (Not supported by all drive types)	
10	REMOTE_CMD	1	Fieldbus control enabled	
		0	Control word <> 0 or reference <> 0: Retain last Control word and reference. Control word = 0 and reference = 0: Fieldbus control enabled.	
11		1	Vendor-specific bit as defined by PROFIdrive parameter 933	Start homing procedure.
		0		Stop homing procedure.
12			Vendor-specific bit as defined by PROFIdrive parameter 934. As default mapped to Drive Main CW bit 12.	
13			Vendor-specific bit as defined by PROFIdrive parameter 935. As default mapped to Drive Main CW bit 13.	
14			Vendor-specific bit as defined by PROFIdrive parameter 936. As default mapped to Drive Main CW bit 14.	
15			Vendor-specific bit as defined by PROFIdrive parameter 937. As default mapped to Drive Main CW bit 15.	

Status word contents

The table below shows the contents of the Status word for the PROFIdrive communication profile (PROFIdrive parameter 968). The upper case boldface text refers to the states of the state machine on page 85.

Bit	Name	Value	STATE/Description	
			Speed control mode	Positioning mode
0	RDY_ON	1	READY TO SWITCH ON	
		0	NOT READY TO SWITCH ON	
1	RDY_RUN	1	READY TO OPERATE	
		0	OFF1 ACTIVE	
2	RDY_REF	1	ENABLE OPERATION	
		0	OPERATION INHIBIT	

Bit	Name	Value	STATE/Description	
			Speed control mode	Positioning mode
3	TRIPPED	1	FAULT	
		0	No fault	
4	OFF_2_STA	1	OFF2 inactive	
		0	OFF2 ACTIVE	
5	OFF_3_STA	1	OFF3 inactive	
		0	OFF3 ACTIVE	
6	SWC_ON_INHIB	1	SWITCH-ON INHIBIT ACTIVE	
		0	SWITCH-ON INHIBIT NOT ACTIVE	
7	ALARM	1	Warning/Alarm	
		0	No Warning/Alarm	
8	AT_SETPOINT	1	OPERATING. Actual value equals reference value (= is within tolerance limits).	
		0	Actual value differs from reference value (= is outside tolerance limits).	
9	REMOTE	1	Automation system is requested to assume control.	
		0	Control by automation system is not possible. Control is possible only at the device or by another interface.	
10		1	Actual frequency or speed value equals or is greater than supervision limit.	Target position reached.
		0	Actual frequency or speed value is within supervision limit.	Not at target position
11		1	Mapped to PROFIdrive SW bit 11.	Homing procedure was executed and is valid.
		0	Vendor-specific bit as defined by PROFIdrive parameter 939. As default mapped to PROFIdrive SW bit 11.	No valid home position available.
12		1	Mapped to PROFIdrive SW bit 11.	Traversing task acknowledgement (0 → 1)
		0	Vendor-specific bit as defined by PROFIdrive parameter 940. As default mapped to PROFIdrive SW bit 12.	

84 PROFINET IO – Communication profiles

Bit	Name	Value	STATE/Description	
			Speed control mode	Positioning mode
13		1	Mapped to PROFIdrive SW bit 11.	Drive stopped.
		0	Vendor-specific bit as defined by PROFIdrive parameter 941. As default mapped to PROFIdrive SW bit 13.	Drive operates. Traversing task is executed (n <> 0).
14			Vendor-specific bit as defined by PROFIdrive parameter 942. As default mapped to PROFIdrive SW bit 14.	
15			Vendor-specific bit as defined by PROFIdrive parameter 943	

State machine for all operating modes

The general PROFIdrive state machine for all operating modes is shown below.

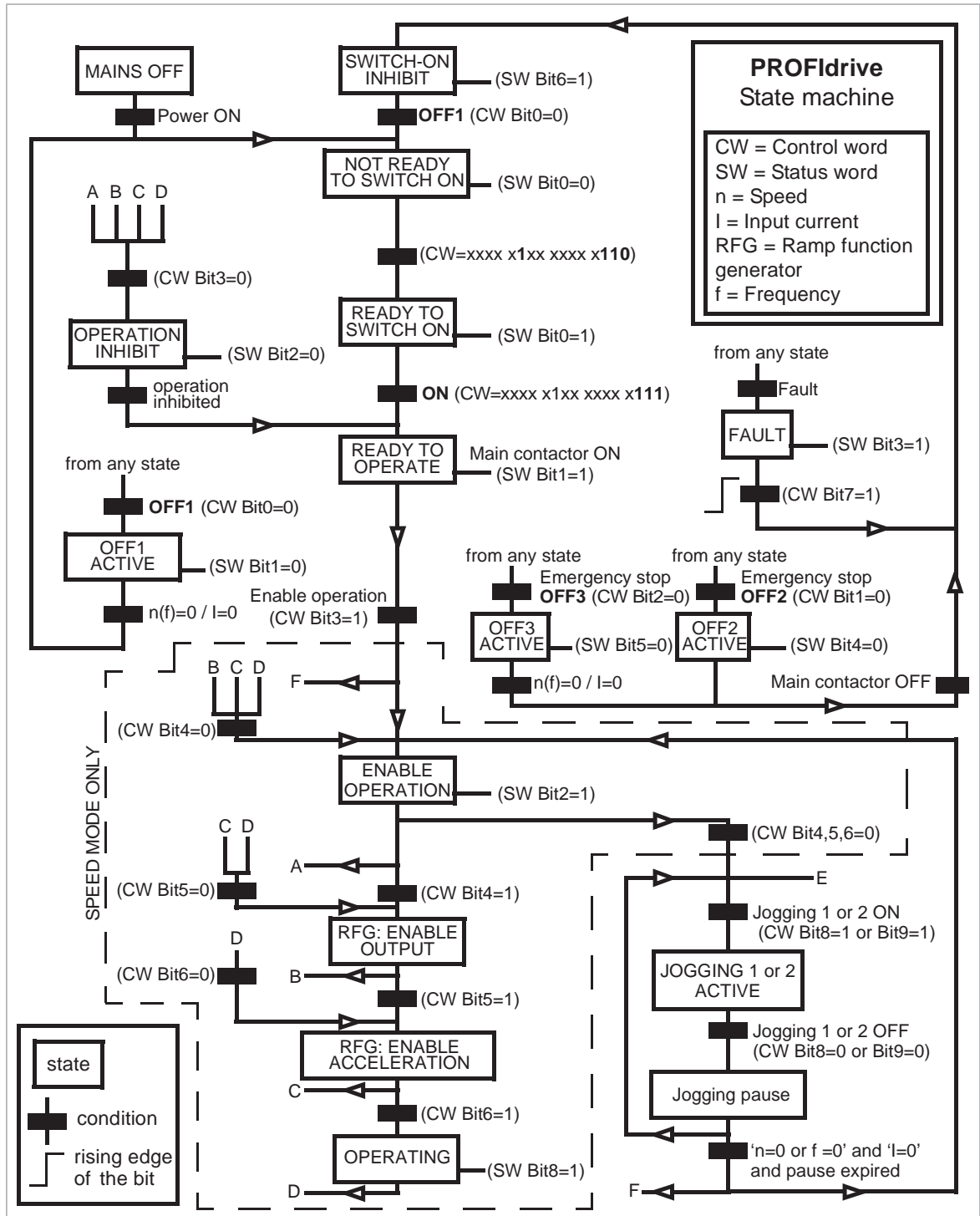

State machine for the positioning mode

The PROFIdrive state machine for the positioning mode is shown below.

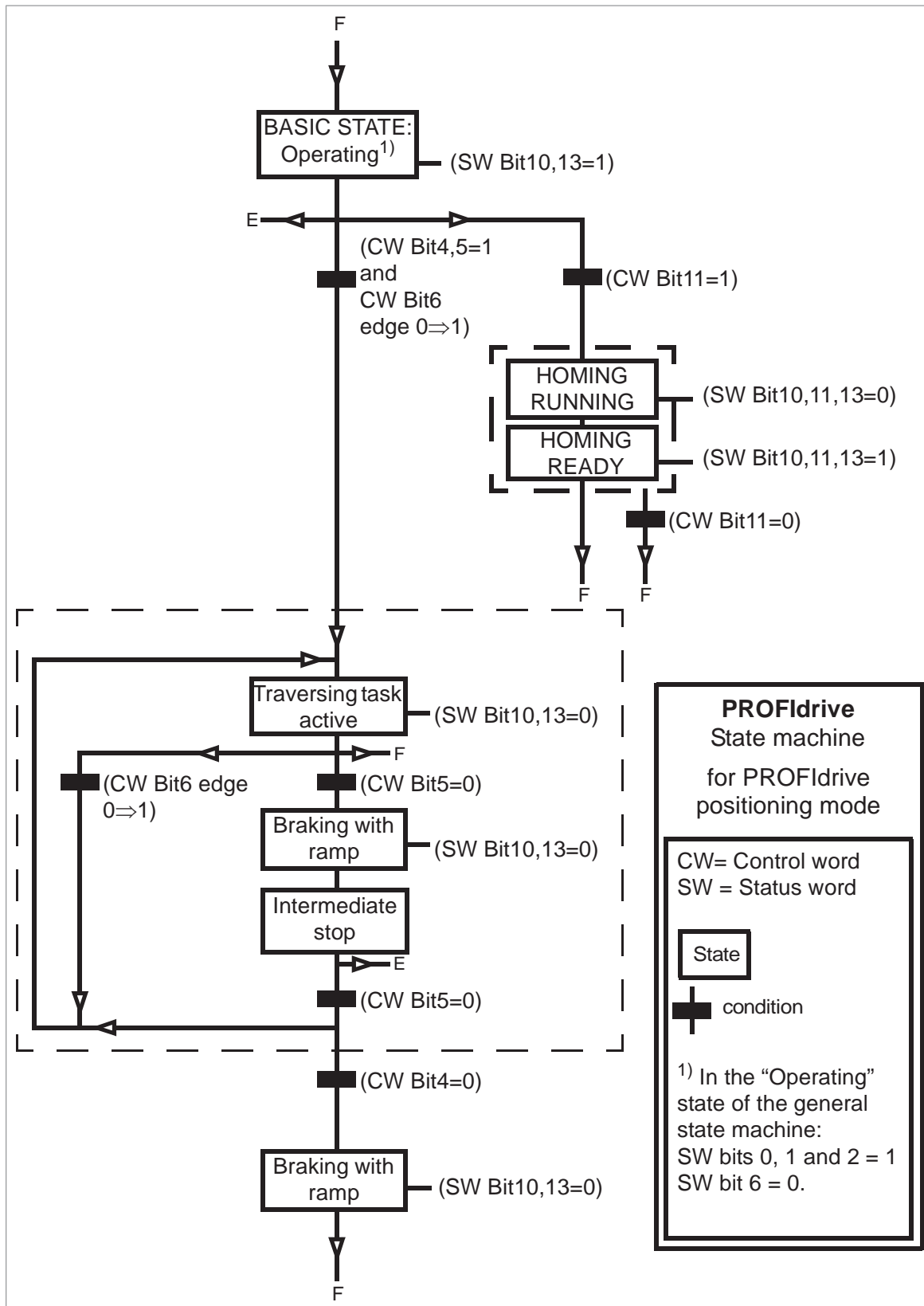

■ References

ABB drives can receive control information from multiple sources including analog and digital inputs, the drive control panel and a fieldbus adapter module (for example, the FPNO-21 module). To control the drive through PROFINET, select the module as the source for control information, for example, reference.

References in speed control mode

In the speed control mode, references are 16-bit or 32-bit words that contain a sign bit and a 15-bit or 31-bit integer. A negative reference (indicating reversed direction of rotation) is formed by calculating the two's complement from the corresponding positive reference.

A 16-bit speed reference (REF or NSOLL_A) in hexadecimal (0...4000h) corresponds to 0...100% of Maximum Reference (as defined with a drive parameter).

A 32-bit speed reference (NSOLL_B) in hexadecimal (0...4000 0000h) corresponds to 0...100% of Maximum Reference (as defined with a drive parameter).

■ Actual values

The actual values are 16-bit or 32-bit words that contain information on the operation of the drive. Select the functions to be monitored with a drive parameter.

Actual values in speed control mode

The scaling of 16-bit actual speed values (ACT or NIST_A) in hexadecimal (0...4000h) corresponds to 0...100% of the maximum reference (as defined with a drive parameter, for example, speed scaling in ACSM1, ACS850, ACQ810, ACS480, ACS580 and ACS880, and external reference in ACS355).

The scaling of 32-bit actual speed values (NIST_B) in hexadecimal (0...4000 0000h) corresponds to 0...100% of the maximum reference (as defined with a drive parameter, for example, speed scaling in ACSM1, ACS850, ACQ810, ACS480, ACS580 and ACS880, and external reference in ACS355).

ABB Drives communication profile

■ Control word and Status word

The Control word is the primary procedure to control the drive from a fieldbus system. The fieldbus master station sends it to the drive through the adapter module. The drive switches between its states according to the bit-coded instructions in the Control word and returns status information to the master in the Status word.

The contents of the Control word and the Status word are detailed below. For the drive states, refer to page [91](#).

Control word contents

The table below shows the contents of the Control word for the ABB Drives communication profile. The upper case boldface text refers to the states shown on page [91](#).

88 PROFINET IO – Communication profiles

Bit	Name	Value	STATE/Description
0	OFF1_CONTROL	1	Proceed to READY TO OPERATE .
		0	Stop along currently active deceleration ramp. Proceed to OFF1 ACTIVE ; proceed to READY TO SWITCH ON unless other interlocks (OFF2, OFF3) are active.
1	OFF2_CONTROL	1	Continue operation (OFF2 inactive).
		0	Emergency OFF, coast to stop. Proceed to OFF2 ACTIVE , proceed to SWITCH-ON INHIBITED .
2	OFF3_CONTROL	1	Continue operation (OFF3 inactive).
		0	Emergency stop, stop within time defined by drive parameter. Proceed to OFF3 ACTIVE ; proceed to SWITCH-ON INHIBITED .  WARNING! Make sure that the motor and driven machine can be stopped using this stop mode.
3	INHIBIT_OPERATION	1	Proceed to OPERATION ENABLED . Note: Run enable signal must be active; see drive documentation. If the drive is set to receive the Run enable signal from the fieldbus, this bit activates the signal.
		0	Inhibit operation. Proceed to OPERATION INHIBITED .
4	RAMP_OUT_ZERO	1	Normal operation. Proceed to RAMP FUNCTION GENERATOR: OUTPUT ENABLED .
		0	Force Ramp Function Generator output to zero. Drive ramps to stop (current and DC voltage limits in force).
5	RAMP_HOLD	1	Enable ramp function. Proceed to RAMP FUNCTION GENERATOR: ACCELERATOR ENABLED .
		0	Halt ramping (Ramp Function Generator output held).
6	RAMP_IN_ZERO	1	Normal operation. Proceed to OPERATION . Note: This bit is effective only if the fieldbus interface is set as the source for this signal by drive parameters.
		0	Force Ramp Function Generator input to zero.
7	RESET	0 → 1	Fault reset if an active fault exists. Proceed to SWITCH-ON INHIBITED . Note: This bit is effective only if the fieldbus interface is set as the source for this signal by drive parameters.
		0	Continue normal operation.
8 ... 9	Reserved		
10	REMOTE_CMD	1	Fieldbus control enabled
		0	Control word and reference not getting through to the drive, except for CW bits OFF1, OFF2 and OFF3.

Bit	Name	Value	STATE/Description
11	EXT_CTRL_LOC	1	Select External Control Location EXT2. Effective if control location parameterized to be selected from fieldbus.
		0	Select External Control Location EXT1. Effective if control location parameterized to be selected from fieldbus.
12 ... 15	Drive-specific (For information, refer to the drive documentation.)		

Status word contents

The table below shows the contents of the Status word for the ABB Drives communication profile. The upper case boldface text refers to the states shown on page 91.

Bit	Name	Value	STATE/Description
0	RDY_ON	1	READY TO SWITCH ON
		0	NOT READY TO SWITCH ON
1	RDY_RUN	1	READY TO OPERATE
		0	OFF1 ACTIVE
2	RDY_REF	1	OPERATION ENABLED
		0	OPERATION INHIBITED
3	TRIPPED	1	FAULT
		0	No fault
4	OFF_2_STA	1	OFF2 inactive
		0	OFF2 ACTIVE
5	OFF_3_STA	1	OFF3 inactive
		0	OFF3 ACTIVE
6	SWC_ON_INHIB	1	SWITCH-ON INHIBITED
		0	–
7	ALARM	1	Warning/Alarm
		0	No warning/alarm
8	AT_SETPOINT	1	OPERATION. Actual value equals reference (= is within tolerance limits, that is, in speed control, speed error is 10% max. of nominal motor speed).
		0	Actual value differs from reference (= is outside tolerance limits).
9	REMOTE	1	Drive control location: REMOTE (EXT1 or EXT2)
		0	Drive control location: LOCAL
10	ABOVE_LIMIT	1	Actual frequency or speed equals or exceeds supervision limit (set by drive parameter). Valid in both directions of rotation.
		0	Actual frequency or speed within supervision limit

90 PROFINET IO – Communication profiles

Bit	Name	Value	STATE/Description
11	EXT_CTRL_LOC	1	External Control Location EXT2 selected. Note concerning ACS880: This bit is effective only if the fieldbus interface is set as the target for this signal by drive parameters. User bit 0 selection (06.33)
		0	External Control Location EXT1 selected
12	EXT_RUN_ENABLE	1	External Run Enable signal received. Note concerning ACS880: This bit is effective only if the fieldbus interface is set as the target for this signal by drive parameters. User bit 1 selection (06.34)
		0	No External Run Enable signal received
13 ... 14	Drive-specific (For information, refer to the drive documentation.)		
15	FBA_ERROR	1	Communication error detected by fieldbus adapter module
		0	Fieldbus adapter communication OK

FPNO-21). To have the drive controlled through the fieldbus, you must select the module as the source for control information, for example, reference.

Scaling

References are scaled as shown below.

Note: The values of REF1 MAX and REF2 MAX are set with drive parameters. Refer to the drive manuals for further information.

In ACSM1, ACS850, ACQ810, ACS480, ACS580 and ACS880, the speed reference (REFx) in decimal (0...20000) corresponds to 0...100% of the speed scaling value (as defined with a drive parameter). You can adjust the minimum reference value in some drives. For more information, refer to parameter 46.06 or 46.07 in the drive firmware manual.

In ACS355, drive parameter REFx MIN may limit the actual minimum reference.

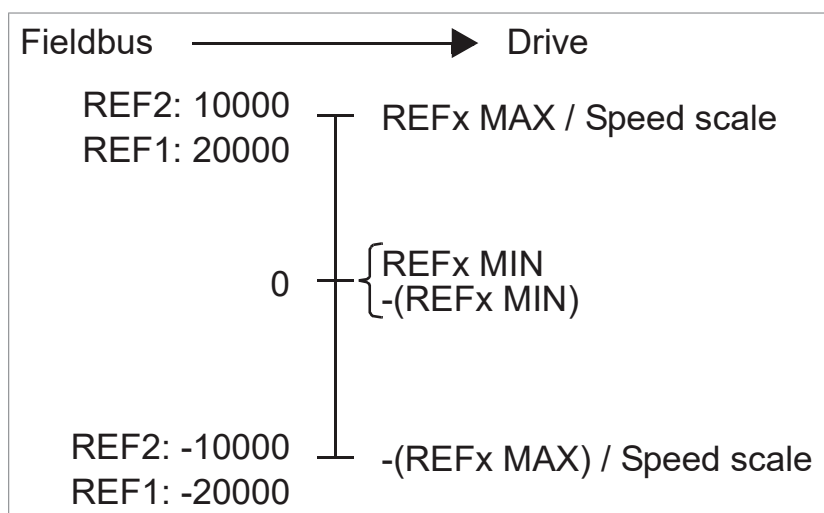

■ Actual values

Actual values are 16-bit words containing information on the operation of the drive. The functions to be monitored are selected with a drive parameter.

Scaling

Actual values are scaled as shown below.

Note: The values of REF1 MAX and REF2 MAX are set with drive parameters. See the drive manuals for further information.

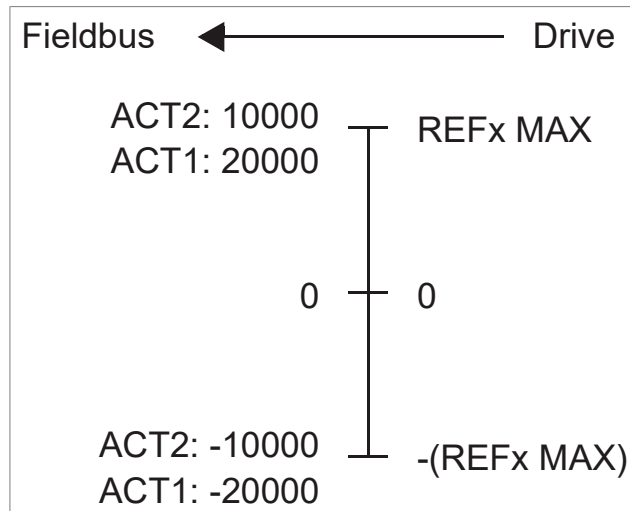

PROFIdrive v4.2 communication profile

■ Supported drives

PROFIdrive v4.2 supports the drives listed in [Compatibility \(page 13\)](#). It does not support ACS355 drives.

■ Control word and Status word

The Control word (PROFIdrive parameter 967) is the primary procedure to control the drive from a fieldbus system. The fieldbus master station sends it to the drive through the adapter module. The drive switches between its states according to the bit-coded instructions in the Control word and returns status information to the master in the Status word (PROFIdrive parameter 968).

The contents of the Control word and the Status word are detailed below. See the drive documentation for information on the drive-specific bits. For the drive states, refer to page [96](#).

Control word contents

The table below shows the contents of the Control word for the PROFIdrive v4.2 communication profile. The upper case boldface text refers to the states shown on page [96](#).

Bit	Name	Value	STATE/Description
0	ON	1	Proceed to READY TO OPERATE .
	OFF1	0	Emergency OFF, stop by the selected deceleration ramp. Proceed to RAMP STOP ; proceed further to READY TO SWITCH ON unless other interlocks (OFF2, OFF3) are active.
1	OFF2	1	Continue operation (OFF2 inactive).
		0	Emergency OFF, coast to stop. Proceed to SWITCHING ON INHIBITED .
2	OFF3	1	Continue operation (OFF3 inactive).
		0	Emergency stop, stop according to the fastest possible deceleration mode. Proceed to QUICK STOP ; proceed further to SWITCHING ON INHIBITED .  WARNING! Make sure that the motor and driven machine can be stopped using this stop mode.
3	OPERATION_ENABLE	1	Proceed to ENABLE OPERATION .
		0	Inhibit operation. Proceed to READY TO OPERATE .
4	ENABLE_RAMP_GENERATOR	1	Normal operation. Enables the ramp function generator's output.
		0	Ramp function generator's output is forced to zero.
5	UN-FREEZE_RAMP_GENERATOR	1	Normal operation. Turns on the ramp function generator.
		0	Ramp function generator's output is frozen to its current value.
6	ENABLE_SETPOINT	1	Normal operation. Sets the velocity reference as the ramp function generator's input.
		0	Ramp function generator's input is forced to zero.
7	RESET	0 → 1	Fault reset if an active fault exists.
		0	Continue normal operation.
8	JOGGING_1		Not supported in PROFIdrive v4.2.
9	JOGGING_2		Not supported in PROFIdrive v4.2.
10	REMOTE_CMD	1	Fieldbus control enabled
		0	
11	EXT_CTRL_LOC		Vendor-specific bit.
12			Vendor-specific bit. Mapped to Drive Main CW bit 12.
13			Vendor-specific bit. Mapped to Drive Main CW bit 13.
14			Vendor-specific bit. Mapped to Drive Main CW bit 14.
15			Vendor-specific bit. Not used.

Status word contents



The table below shows the contents of the Status word for the PROFIdrive v4.2 communication profile. The upper case boldface text refers to the states shown in the state machine on page 96.

Bit	Name	Value	STATE/Description
0	RDY_ON	1	READY TO SWITCH ON
		0	Not READY TO SWITCH ON
1	RDY_RUN	1	READY TO OPERATE
		0	Not READY TO OPERATE
2	RDY_REF	1	OPERATION ENABLED
		0	Operation disabled
3	TRIPPED	1	FAULT
		0	No fault
4	OFF_2_STA	1	OFF2 inactive
		0	OFF2 active
5	OFF_3_STA	1	OFF3 inactive
		0	OFF3 active
6	SWC_ON_INHIB	1	SWITCHING ON INHIBITED
		0	Not SWITCHING ON INHIBITED
7	ALARM	1	Warning/alarm
		0	No warning/alarm
8	SPEED_ERROR_WITH- IN_TOLER- ANCE_RANGE	1	Actual value is within tolerance limits of ramp function generator's output. Note: The behavior is different from PROFIdrive's status word bit 8 (AT_SETPOINT).
		0	Actual value is outside tolerance limits of ramp function generator's output.
9	REMOTE	1	Automation system is requested to assume control.
		0	Control by automation system is not possible. Control is possible only at the device by or by another interface.
10	ABOVE_LIMIT	1	Actual frequency or speed value equals or is larger than supervision limit.
		0	Actual frequency or speed value is within supervision limit.
11			Vendor-specific bit. Mapped to Drive Main SW bit 11.
12			Vendor-specific bit. Mapped to Drive Main SW bit 12.
13			Vendor-specific bit. Mapped to Drive Main SW bit 13.
14			Vendor-specific bit. Mapped to Drive Main SW bit 14.

Bit	Name	Value	STATE/Description
15			Vendor-specific bit. Not used.

State machine

The state machine and definitions for the PROFIdrive v4.2 communication profile are shown below. The jogging mode is not available in PROFIdrive v4.2.

Symbol	Definition
n	Speed
	State transition priority. Transitions with more circles have a higher priority. A transition with no circles has the lowest priority.
	Rising edge of the bit
	Condition

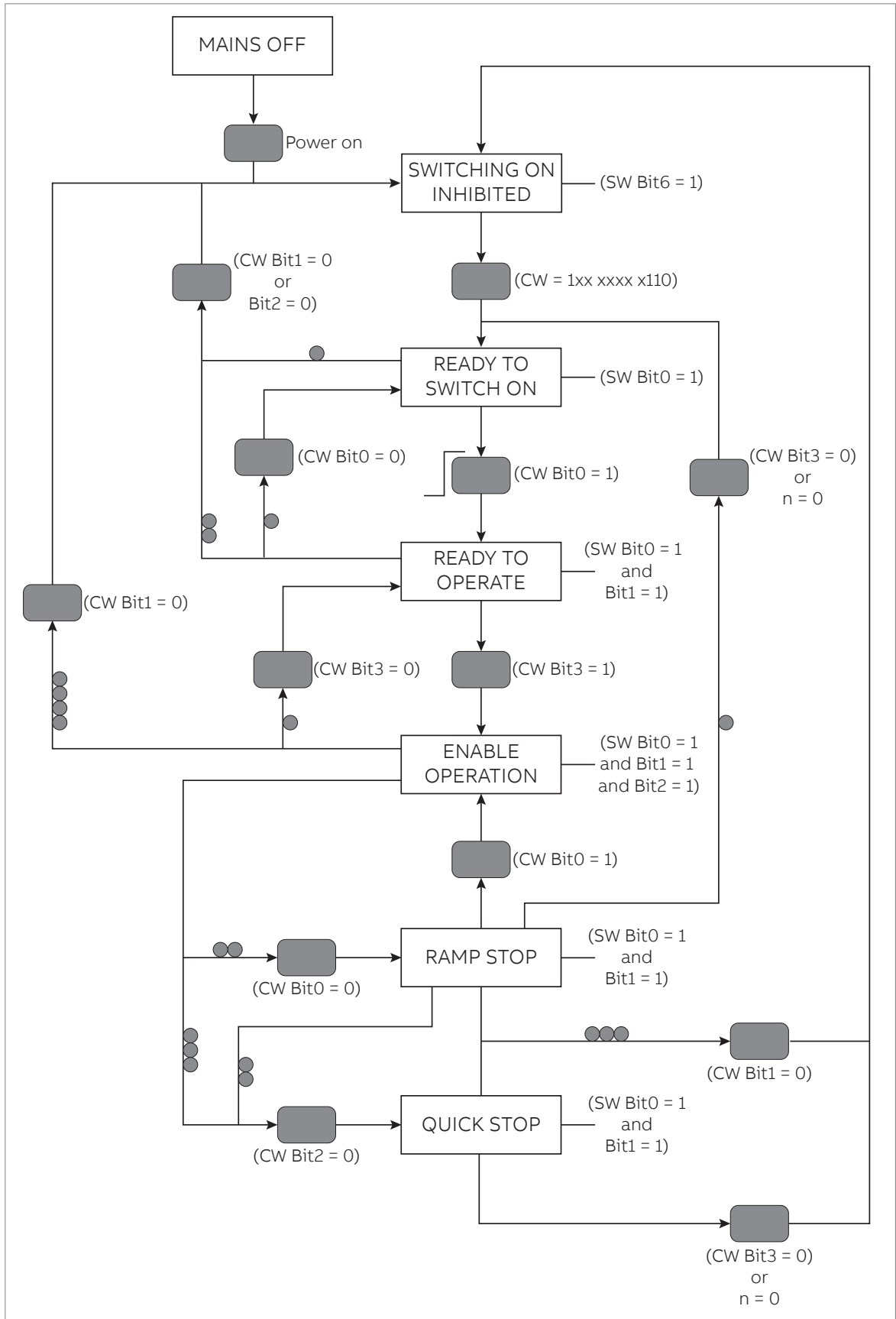

For PROFIdrive v4.2, the ramp function generator operates the same as in the PROFIdrive profile. The only difference is that if the PROFIdrive control word bit4 is set to false while in the **RAMP STOP** state, the drive stops as fast as possible within

the current and DC voltage limits. This occurs because setting bit4 to false forces the output of the ramp function generator to 0.

■ References

ABB drives can receive control information from multiple sources including analog and digital inputs, the drive control panel and a fieldbus adapter module (for example, FPNO-21). To have the drive controlled through PROFINET, you must select the module as the source for control information, for example, reference.

References in speed control mode

In the speed control mode, references are 16-bit or 32-bit words containing a sign bit and a 15-bit or 31-integer. A negative reference (indicating reversed direction of rotation) is formed by calculating the two's complement from the corresponding positive reference.

A 16-bit speed reference (REF or NSOLL_A) in hexadecimal (0...4000h) corresponds to 0...100% of Maximum Reference (as defined with a drive parameter).

A 32-bit speed reference (NSOLL_B) in hexadecimal (0...4000 0000h) corresponds to 0...100% of Maximum Reference (as defined with a drive parameter).

■ Actual values

Actual values are 16-bit or 32-bit words containing information on the operation of the drive. The functions to be monitored are selected with a drive parameter.

Actual values in speed control mode

The scaling of 16-bit actual speed values (ACT or NIST_A) in hexadecimal (0...4000h) corresponds to 0...100% of the maximum reference (as defined with a drive parameter, for example, speed scaling in ACS880).

The scaling of 32-bit actual speed values (NIST_B) in hexadecimal (0...4000 0000h) corresponds to 0...100% of the maximum reference (as defined with a drive parameter, for example, speed scaling in ACS880).



PROFINET IO – Communication protocol

Contents of this chapter

This chapter describes the PROFINET IO communication protocol for the adapter module. For detailed information on PROFINET IO communication, refer to the PROFINET specification Application Layer protocol for decentralized periphery and distributed automation v2.0.

PROFINET IO

PROFINET IO is a fieldbus protocol for communication between programmable controllers and distributed field devices in an Ethernet network. The protocol classifies devices into I/O controllers, I/O supervisors and I/O devices, which have a specific collection of services.

PROFINET IO uses three different communication channels to exchange data:

- The standard UDP/IP and TCP/IP channel for parameterization and configuration of devices and for acyclic operations.
- The real time (RT) channel for cyclic data transfer and alarms.
- The isochronous real time (IRT) channel, for example, in motion control applications (not implemented in FPNO-21).

PROFINET IO devices are structured in slots and sub-slots, that can contain modules and sub-modules correspondingly. A device can have almost any number of slots and sub-slots, and they can be virtual or real. Device-specific data is represented in slot 0; module-specific and sub-module-specific data in subsequent slots and sub-slots.

One of the benefits of PROFINET IO is the diagnostics and alarm mechanism. Every module and sub-module provide alarm data to the I/O controller using the cyclic

channel. Diagnostic data can be read non-cyclically from the device by using record data.

The properties and services of a PROFINET IO device are described in a GSD file written in GSDML (General Station Description Markup Language). The GSD file describes the device-specific modules and the method of assigning modules and sub-modules to predefined slots and sub-slots. For more information, refer to [Downloading the GSD file \(page 43\)](#).

PROFINET network settings

In PROFINET, the network devices are identified with station names. The controller uses DCP (Discovery and Configuration protocol) to find devices with configured names from the network. The device with the given name responds with an Identity response that also contains its current IP address.

If the current IP address differs from the address in the hardware configuration of the controller, the controller gives the device a new IP address according to the configuration. This IP is set as temporary, which means that after reboot of the device, the IP address will be 0.0.0.0 as specified in the PROFINET standard.

The recommended IP setting for PROFINET is Static IP and address is 0.0.0.0. With this setting, there is need to configure the IP in only one place (hardware configuration) and this avoids any IP conflicts among the devices.

PROFINET IO in FPNO-21

When PROFINET IO is selected as the communication protocol, the FPNO-21 module can use the ABB Drives, Transparent 16 and Transparent 32 communication profiles, PROFIdrive or PROFIdrive v4.2 profiles. You can select the profile with FPNO-21 configuration parameter 02 Protocol/Profile. You can also select the device access point (DAP) and functional module with the tool.

- Slot 0 has sub-slots, and the DAP module attached to it represents the device itself. These sub-slots are available:
 - sub-slot 0x0001 is DAP
 - sub-slot 0x8000 is interface sub-module
 - sub-slot 0x8001 is port 1
 - sub-slot 0x8002 is port 2.
 - Slot 1 and its sub-slots support other functional modules and sub-modules described in the GSD file. These sub-slots are available:
 1. For PPO types
 - sub-slot 0x0001 is the telegram
 2. For Standard telegrams
 - sub-slot 0x0001 is the Module Access point
 - sub-slot 0x0002 is the telegram
 - Slot 2 is used for PROFIsafe
 - sub-slot 0x0001 is PROFIsafe telegram
-

The services provided by the FPNO-21 module

- Cyclic messaging
- Acyclic parameter access mechanism
- Identification & Maintenance functions (I&M)
- Media Redundancy Protocol (MRP)
- System redundancy (S2)
- Shared Device
- Network Diagnostic (SNMP)
- Topology information (LLDP) with LLDP-MIB
- PROFIdrive parameters (limited in the ABB Drives and Transparent profiles)
- Diagnostic and alarm mechanism (only with the PROFIdrive profiles)
- Fault buffer mechanism (limited in the ABB Drives and Transparent profiles)
- Support PROFIdrive profile for standardized way of controlling drive. Standard telegram 1 & 2 are supported.

Cyclic message types

■ PPO types

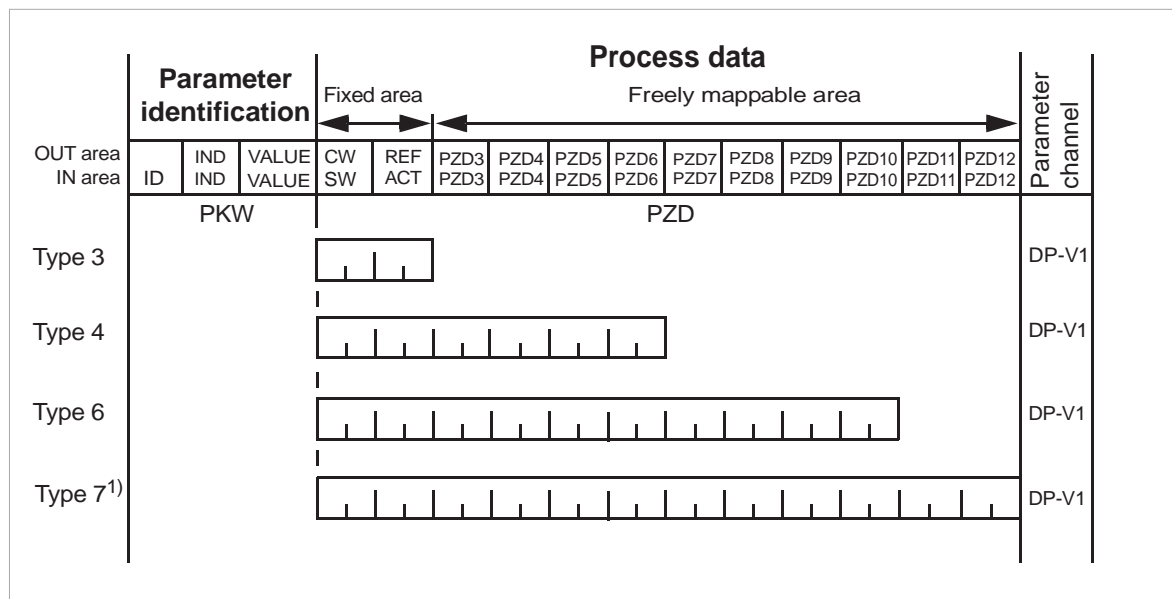

OUT area – Data sent from master to slave (control data)

IN area – Data sent from slave to master (actual data)

Parameter identification:

ID – Parameter identification

IND – Index for arrays

VALUE – Parameter value (Max. 4 bytes)

PKW – Parameter ID/value

Process data:

CW – Control word

SW – Status word

REF – Reference

ACT – Actual value

PZD – Process data (application-specific)

DW – Data word

■ **Standard telegram (ST) types (DP-V1)**

ST1

	PZD1	PZD2
OUT area	STW1 Control word 1	NSOLL_A Speed set point A
IN area	ZSW1 Status word 1	NIST_A Speed actual value A

ST2

	PZD1	PZD2...3	PZD4
OUT area	STW1 Control word 1	NSOLL_B Speed set point B	STW2 Control word 2
IN area	ZSW1 Status word 1	NIST_B Speed actual value B	ZSW2 Status word 2

ST20

ST20 applies to VIK-Namur profile and to ACS880 with VIK-NAMUR control program.

	PZD1	PZD2	PZD3	PZD4	PZD5	PZD6
OUT area	STW1 Control word 1	NSOLL_A/FSOLL Either speed setpoint or frequency setpoint (depends on the drive control mode)	-	-	-	-
IN area	ZSW1 Status word 1	NIST_A_GLATT / FIST_GLATT Speed actual or frequency actual (depends on the drive control mode)	IAIST_GLATT Output current	ITIST_GLATT or MIST_GLATT Active current (par set 1) or Torque actual (par set 2)	PIST_GLATT Active power	MELD_NAMUR Drive fault word

Note: For the contents of the Control word, the Status word, references and actual values, refer to chapter [PROFINET IO – Communication profiles](#).

■ Behavior of output data

If	Then
IOPS (PLC provider status)=Bad	Output data retains last values
Connection loss	Output data retains last values
After power-up	All output data is 0

Parameter handling using acyclic parameter access mechanism (DP-V1)

PROFINET IO offers record read and write services for the acyclic parameter access mechanism. When the drive parameters or FPNO-21 parameters are accessed, the corresponding slot, sub-slot and index are set, and a PROFIdrive DP-V1 message is placed on the data block of the record read or write frame.

■ Header and frame structures

PROFINET IO uses the DCE RPC (Distributed Computing Environment Remote Procedure Call) protocol for acyclic read and write services. I/O controllers and supervisors take care of formulating most of the request frames. However, it is possible that handling the PROFIdrive request and response headers must be performed in the application logic. The acyclic frame structure, headers and error codes are described further below.

Frames	Dest addr.	Src addr.	Ether type	IP UDP	RPC	NDR	Read or Write	Data
Bytes	6	6	2	28	80	20	64	...

Dest addr. and **Src addr.** are the destination and the source of the communication relationship. The addresses are in hexadecimal format, for example, 00-30-11-02-57-AD.

Ether type is 0x800 for non-real-time communication.

IP and **UDP** fields contain the IP address of the source and the destination as well as the communication ports and length of the message.

RPC contains, for example, the read or write service ID, interface description and selected objects.

NDR request block describes the length of the following data block. The response block also contains bytes **ErrorCode**, **ErrorDecode**, **ErrorCode1** and **ErrorCode2** for presenting the status of the request. The response error codes are listed in the table below.

Byte	Value and meaning
ErrorCode	0xDF (Error Write)
	0xDE (Error Read)
ErrorDecode	0x80 (PNIORW) ErrorCode1 decoded as in ErrorCode1 (page 104) . ErrorCode2 is 0.
	0x81 (PNIO) ErrorCode1 and ErrorCode2 decoded as in ErrorCode1 (page 104) .
ErrorCode1	Error class and error code. Refer to ErrorCode1 (page 104) .

Byte	Value and meaning
ErrorCode2	Not described here

ErrorCode1

The table below lists the ErrorCode1 with PNIO RW decoding.

Error class	Meaning	Error code
0...9	(Reserved)	
10 (0x0A)	Application	0 = Read error 1 = Write error 2 = Module failure 3...7 = Reserved 8 = Version conflict 9 = Feature not supported 10...15 = User-specific
11 (0x0B)	Access	0 = Invalid index 1 = Write length error 2 = Invalid slot 3 = Type conflict 4 = Invalid area 5 = State conflict 6 = Access denied 7 = Invalid range 8 = Invalid parameter 9 = Invalid type 10...15 = User-specific
12 (0x0C)	Resource	0 = Read constraint conflict 1 = Write constraint conflict 2 = Resource busy 3 = Resource unavailable 4...7 = Reserved 8...15 = User-specific
13...15	User-specific	

■ DP-V1 read/write request sequence

A read/write service on a drive parameter is illustrated below.

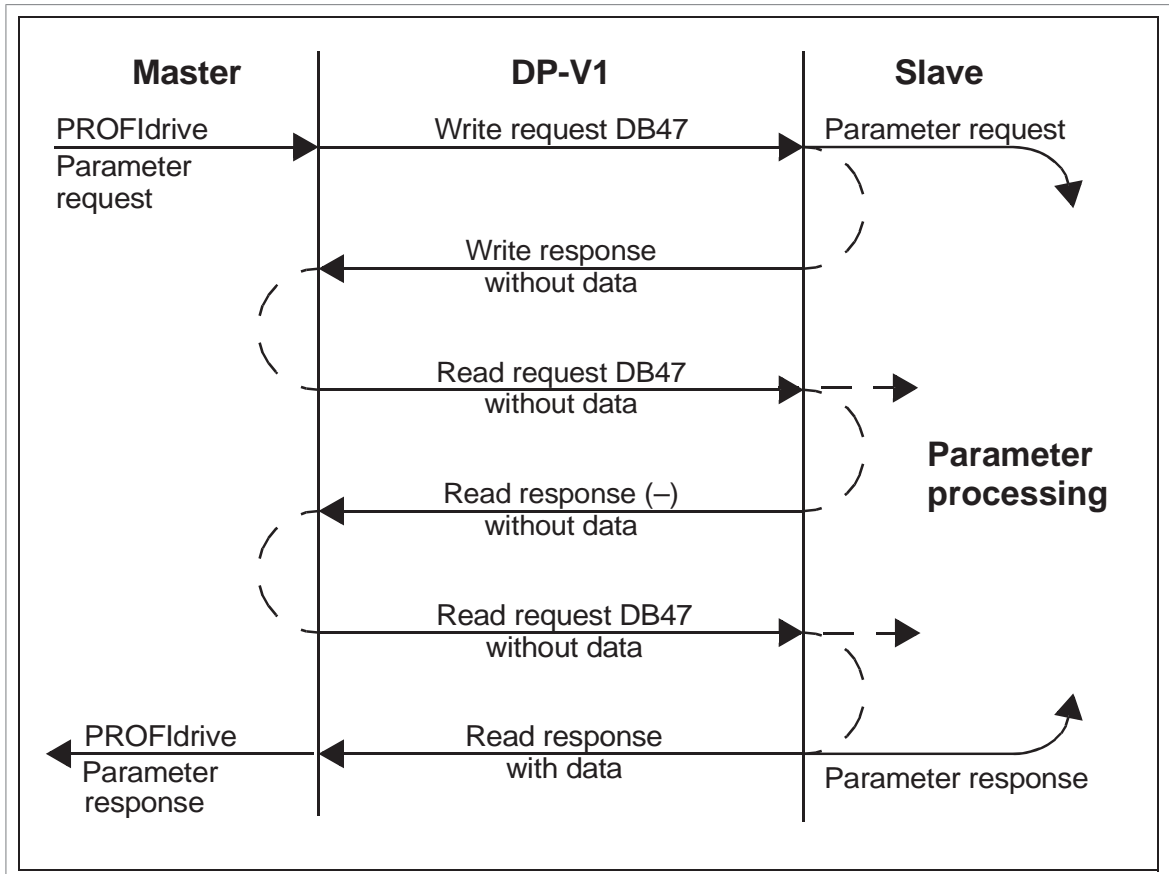

The messaging employs DP-V1 data units. The PROFIdrive parameter request is included within the DP-V1 request as data. Likewise, the DP-V1 response contains the PROFIdrive parameter response as data.

A write request is first sent containing the parameter request. If the write request is valid, the adapter module acknowledges it with a DP-V1 write response with no data. The master will then send a read request. If the adapter module is still busy performing the internal parameter request, it will return a negative response with the DP-V1 error code B5h (State conflict). In this case, the master will repeat the read request until the adapter module has the PROFIdrive response data ready.

If the write request is invalid, a negative response is returned with a DP-V1 error code (refer to [ErrorCode1 \(page 104\)](#)).

Read and write blocks

A read block is used in read requests and responses, while a write block is used in write requests and responses. A request consists of unique identifiers for the connection, addressing information and the length of the record data. A response also contains two additional fields for transferring information.

The table below shows the structure of the read and write blocks in detail.

Field(s)	Description	Range	Type
Service	Request or Response service	Request (0x00) Response (0x80)	UI8
Operation	Read or Write operation	Write (0x08) Read (0x09)	UI8

Field(s)	Description	Range	Type
Block length	Length of the block	0...0xFFFF	UI16
ARUID	Identifier <ul style="list-style-type: none"> • time low • time mid • time high and version • clock • node 		UI32 UI16 UI16 Octet[2] Octet[6]
API	Application process identifier	Device access point (0x0000) PROFIdrive (0x3A00)	UI32
Slot	Slot of the module access point (MAP/PAP)	0x01	UI16
Subslot	Subslot of the module access point (MAP/PAP)	0x01	UI16
Padding	2 bytes		
Index	Index of the record data object	0x2F 0xB02E 0xB02F	UI16
Data length	Length of the data block	0...0xFFFFFFFF	UI32
Additional value 1 (response only)	Field for transferring additional data		UI16
Additional value 2 (response only)	Field for transferring additional data		UI16
Padding	24 bytes for request, 20 bytes for response.		
Data block	Used only with write request and read response.		

Data block

The data block contains a PROFIdrive-specific request or response header.

The table below shows the contents of the PROFIdrive request.

Field(s)	Description	Range	Byte/ Word
Request Reference	Unique identification set by the master. Changed for each new request.	1...255	Byte
Request ID	Request type for the issued block	Request Parameter (01h) Change Parameter (02h)	Byte
Drive Object ID	To be set to 0 or 1.	0...255	Byte
No. of Parameters	Number of the parameters that are present in the request	1...37	Byte
Attribute	Type of the object being accessed. Note: "Description" and "Text" are not supported.	Value (10h) Description (20h) Text (30h)	Byte

Field(s)	Description	Range	Byte/ Word
No. of Elements	Number of the array elements accessed or length of the string accessed. Set to 0 if non-array parameters are used.	0, 1...234	Byte
Parameter Index	Address of the parameter that is being accessed. "0" is allowed by FPNO-21.	1...65535	Word
Subindex	Addresses <ul style="list-style-type: none"> • the first array element of the parameter or • the beginning of a string access or • the text array or • the description element that is being accessed 	0...65535	Word
Format ¹⁾	Refer to the table on page 108.	Refer to the table on page 108.	Byte
Number of Values ¹⁾	Number of the values that follow	0...234	Byte
Values ¹⁾	The values of the request. In case of an odd number of bytes, a zero byte is appended to ensure the word structure of the telegram.	–	Refer to the the Format field.

¹⁾ Only if Request ID is 02h (Change Parameter). The Format, Number of Values and Values fields are repeated for other parameters.

The table below shows the contents of the PROFIdrive response.

Field(s)	Description	Range
Request Reference (mirrored)	Mirrored from the request.	1...255
Response ID	Response from the slave. In case any requested services fail, a "not acknowledged" (NAK) response will be indicated.	Request Param OK (01h) Request Param NAK (81h) Change Param OK (02h) Change Param NAK (82h)
Drive Object ID	To be set to 1.	0...255
No. of Parameters	Number of the parameters that are present in the response	1...37
Format ¹⁾	Refer to the table on page 108.	Refer to the table on page 108.
Number of Values ¹⁾	Number of the values that follow	0...234
Values ¹⁾	The values of the request. In case of an odd number of bytes, a zero byte is appended to ensure the word structure of the telegram.	–

¹⁾ Only if Response ID is 01h (Request Parameter OK). The Format, Number of Values and Values fields are repeated for other parameters.

The table below shows the data types for the Format field in the PROFIdrive response.

Code	Type
0x00	(Reserved)
0x01...0x36	Standard data types 1. Boolean (not supported) 2. Integer8 (not supported) 3. Integer16 4. Integer32 5. Unsigned8 (not supported) 6. Unsigned16 7. Unsigned32 8. Floating point (not supported) 9. Visible string (not supported) ...
0x37...0x3F	(Reserved)
0x40	Zero
0x41	Byte
0x42	Word
0x43	Double word
0x44	Error
0x45...0xFF	(Reserved)

The table below shows the PROFIdrive parameter request error codes.

Error #	Meaning	Used at
00h	Impermissible parameter number	Access to an unavailable parameter
01h	Parameter value cannot be changed	Change access to a parameter value that cannot be changed
02h	Low or high limit exceeded	Change access with a value outside the limits
03h	Invalid subindex	Access to an unavailable subindex
04h	No array	Access with a subindex to a non-indexed parameter
05h	Incorrect data type	Change access with a value that does not match the data type of the parameter
06h	Setting not permitted (can only be reset)	Change access with a value unequal to 0 when this is not permitted
07h	Description element cannot be changed	Change access to a description element that cannot be changed
09h	No description data available	Access to an unavailable description (parameter value is available)
0Bh	No operation priority	Change access rights without rights to change parameters
0Fh	No text array available	Access to a text array that is not available (Parameter value is available.)

Error #	Meaning	Used at
11h	Request cannot be executed because of operating mode	Access is temporarily not possible for reasons that are not specified in detail.
14h	Value impermissible	Change access with a value that is within limits but is not permissible for other long-term reasons (parameter with defined single values)
15h	Response too long	The length of the current response exceeds the maximum transmittable length.
16h	Parameter address impermissible	Illegal value or value that is not supported for the attribute, number of elements, parameter number or sub-index, or a combination
17h	Illegal format	Write request: Illegal format or format of parameter data that is not supported
18h	Number of values inconsistent	Write request: Number of values of the parameter data does not match the number of elements at the parameter address.
21h	Service not supported	Illegal or unknown request ID (response ID will be 80h)
65h ... FF	Manufacturer-specific error area	–
65h	Vendor-specific error	Vendor-specific error
66h	Request not supported	Request not supported
67h	Communication error	Request cannot be completed because of a communication error.
6Eh	Non-volatile error	Failure during write to non-volatile memory
6Fh	Time-out error	Request aborted because of a timeout.
78h	PZD map failure	Parameter cannot be mapped to PZD (size mismatch or non-existent).
79h	PZD memory failure	Parameter cannot be mapped to PZD (out of memory).
7Ah	Multiple PZD map	Parameter cannot be mapped to PZD (multiple PZD write).
82h	Control word bit map	Cannot map Control word bit (parameter 933...937, eg, double mapping of bits).
8Ch	Set torque mode error	Cannot change mode to TORQUE (frequency is used).
90h	Illegal Request ID	The request ID of the response is illegal.
96h	Internal buffer	Buffer overflow
A0h	Internal communication	Communication error between the module and the drive

■ **Function blocks for sending DP-V1 messages (Siemens S7)**

In IEC 61131-3 compatible systems, function blocks are available for accessing data non-cyclically. In Siemens S7, SFB 52 "RDREC" can be used for reading and SFB53 "WRREC" for writing data records as follows:

- On INDEX: Connect the value 0xB02F, 0xB02E or 0x2F.
- On Write record: Set the length of the DP-V1 write request to MLEN.
- On Read record: Set the maximum length of the DP-V1 read response.
- Connect the DP-V1 message to RECORD.

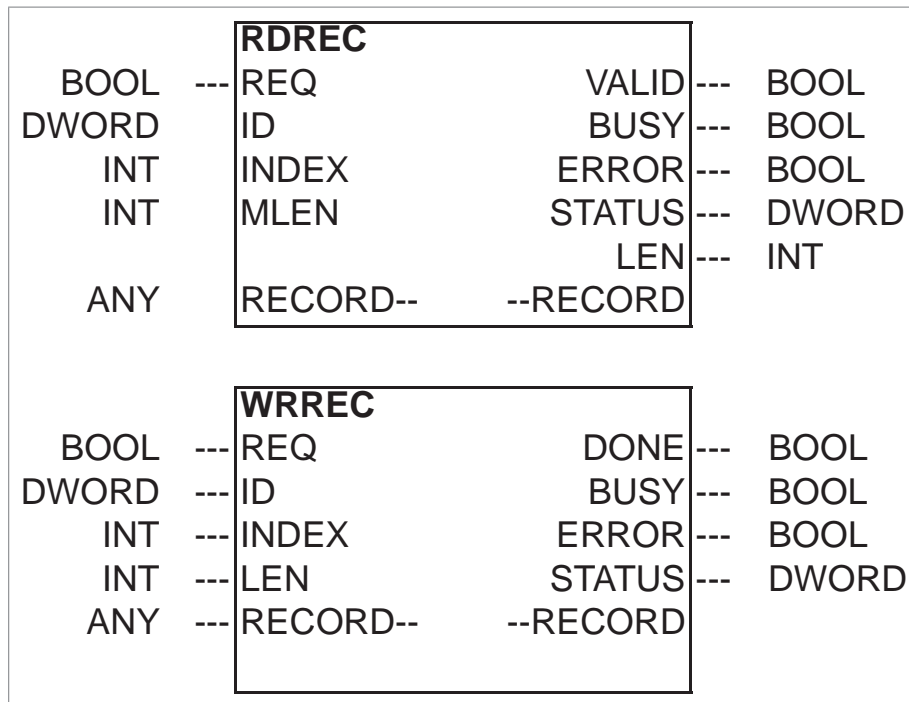

Note: The function block names for Siemens 12xx and 15xx series PLCs are RD_REC and WR_REC, and this naming convention is also applicable for other blocks.

For more information on the above function blocks, see document Communication Function Blocks for PROFIBUS DP and PROFINET IO v2.0 available at www.profibus.com.

■ **Parameter data transfer examples**

These examples show how the DP-V1 READ and WRITE mechanisms transfer parameter data.

Only the data block part of the request is presented in the examples. Refer to [Read and write blocks \(page 105\)](#).

Example 1a: Reading a drive parameter (array element)

Note: Drive parameter access is not available in PROFIdrive v4.2 profile. Refer to parameter [02 Protocol.Profile](#).

Drive parameters are addressed so that the drive parameter group corresponds to the Parameter index (PNU), and the drive parameter number within the group corresponds to the Subindex (IND). In the following example, a value is read from drive parameter 12.04 (0C.04h).

- DP-V1 Write request (Read parameter value):

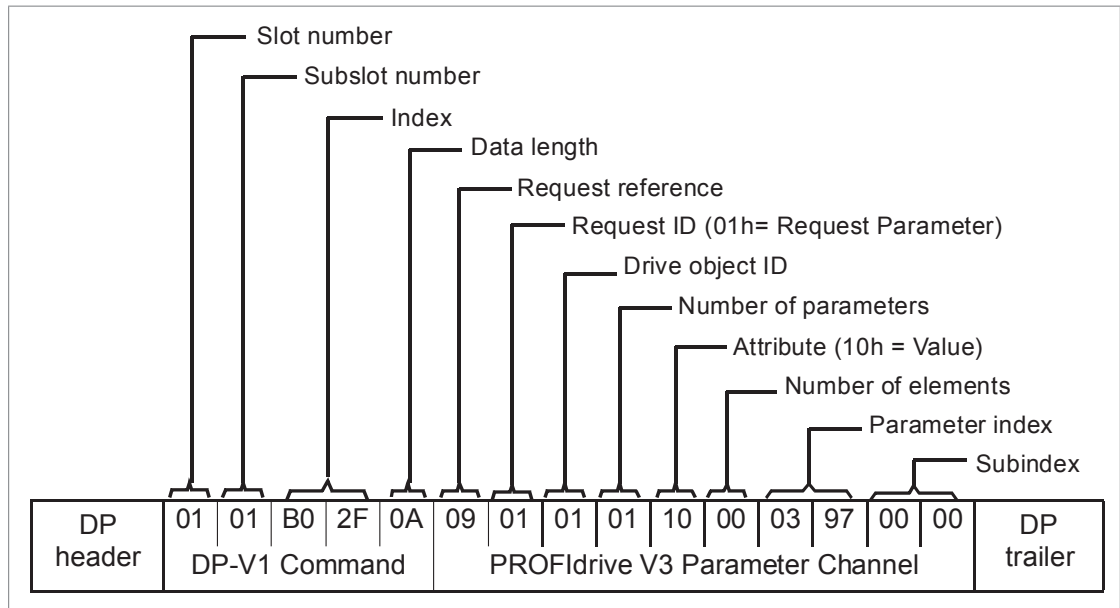

- Positive Read response to DP-V1 Read request:

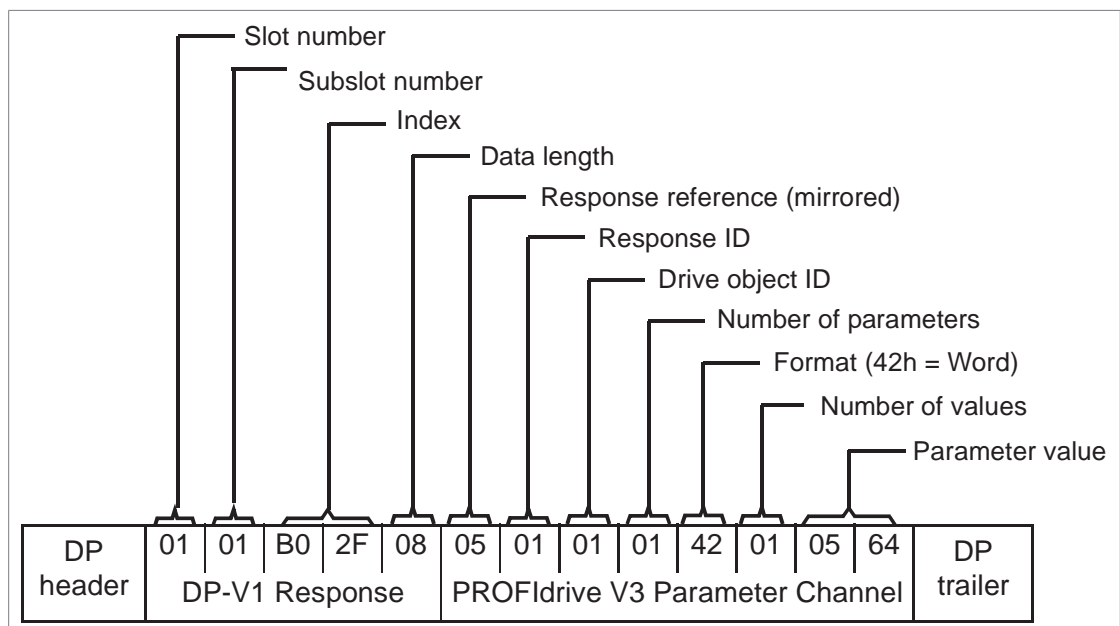

- Negative response to PROFIdrive Read request:

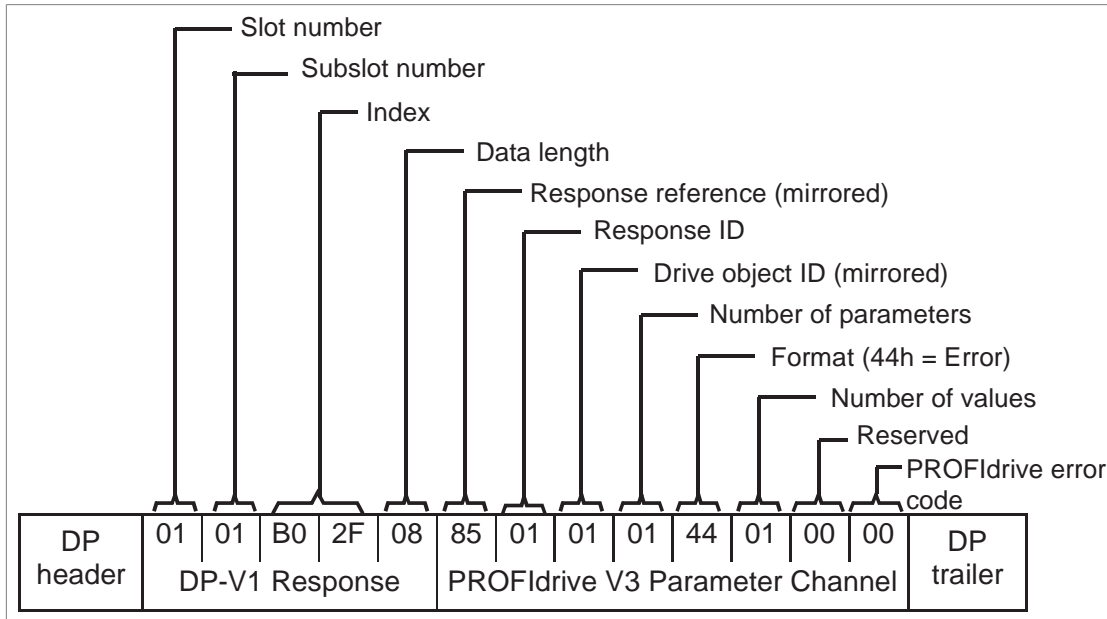

Example 1b: Reading 3 drive parameters (multi-parameter)

Note: Drive parameter access is not available in PROFIdrive v4.2 profile. Refer to parameter [02 Protocol.Profile](#).

In this example, three parameters (12.04, 20.08 and 30.19) are read using one telegram.

- DP-V1 Write request (Read parameter value)

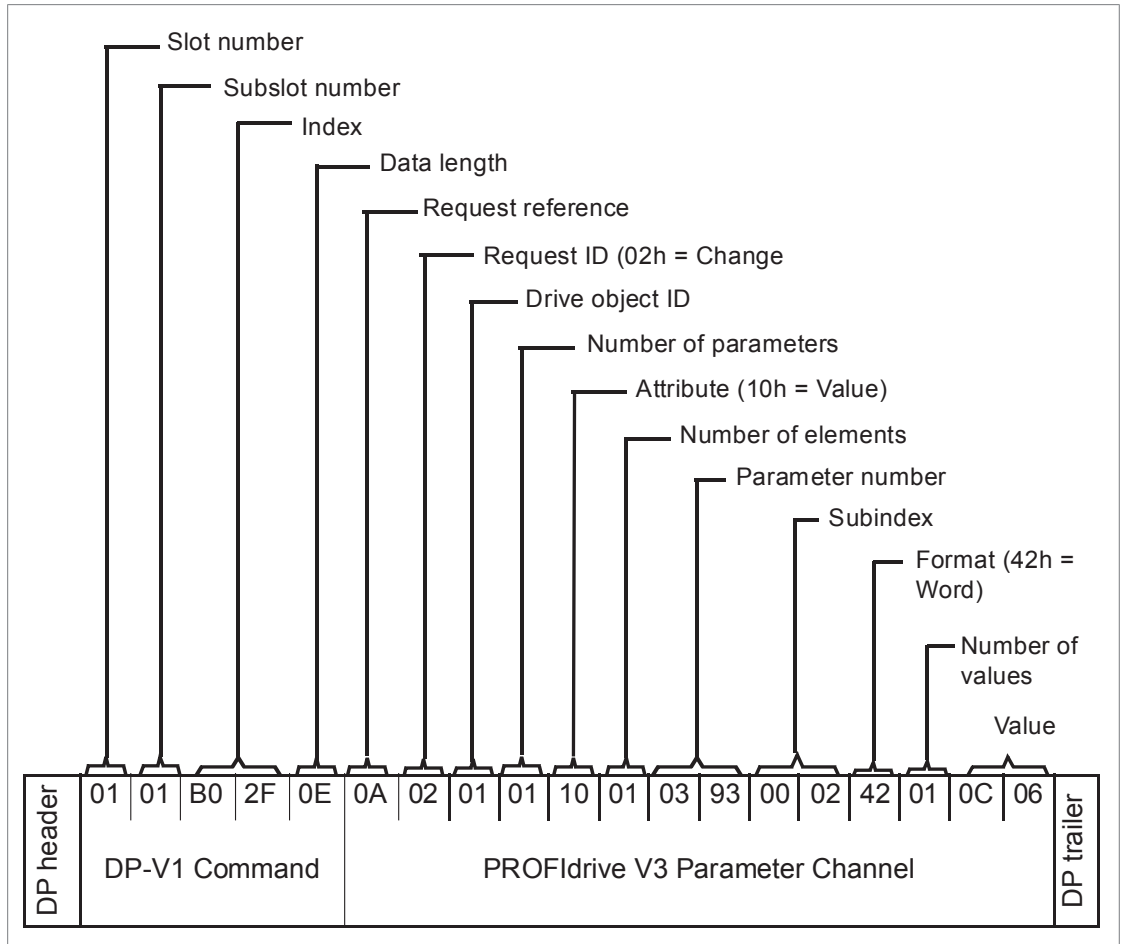

- Positive Read response to DP-V1 Read request:

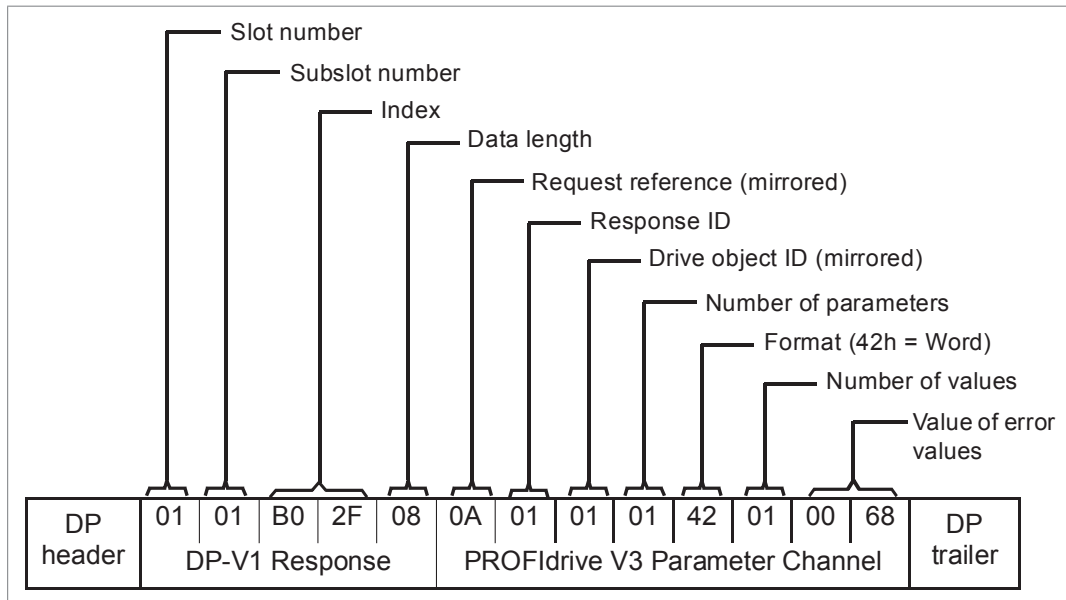

The values 190h (400), 1F4h (500) and 1Eh (30) are returned.

Example 2a: Writing a drive parameter (one array element)

Note: Drive parameter access is not available in PROFIdrive v4.2 profile. Refer to parameter [02 Protocol.Profile](#).

Drive parameters are addressed so that the drive parameter group corresponds to the Parameter index (PNU), and the drive parameter number within that group corresponds to the Subindex (IND). In the following example, a value is written to drive parameter 12.02 (0C.02h).

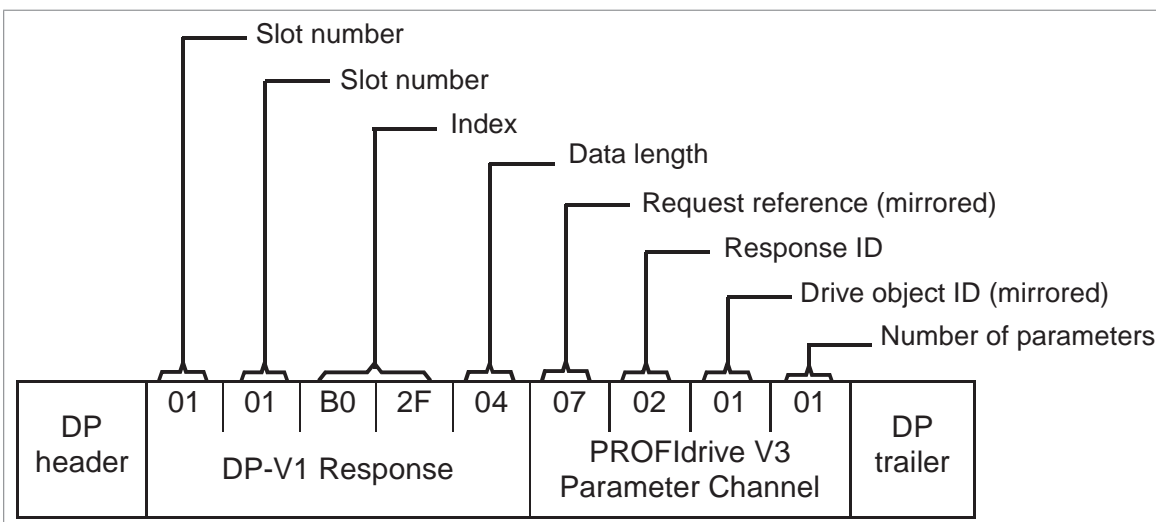
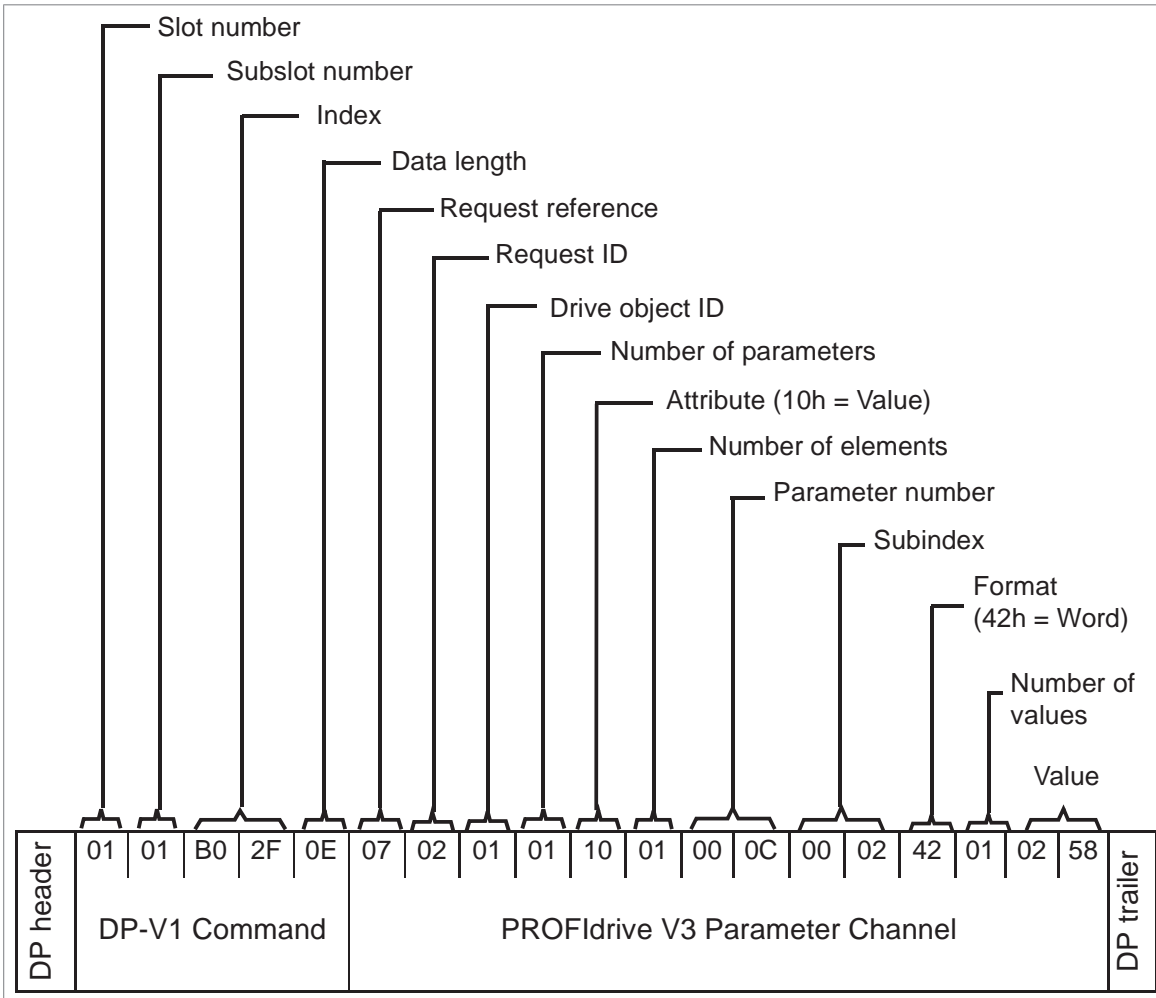

Example 2b: Writing 2 drive parameters (multi-parameter)

Note: Drive parameter access is not available in PROFIdrive v4.2 profile. Refer to parameter [02 Protocol.Profile](#).

In this example, the values 300 (12Ch) and 500 (1F4h) are written to drive parameters 12.02 (0C.02h) and 20.08 (14.08h) respectively using one telegram.

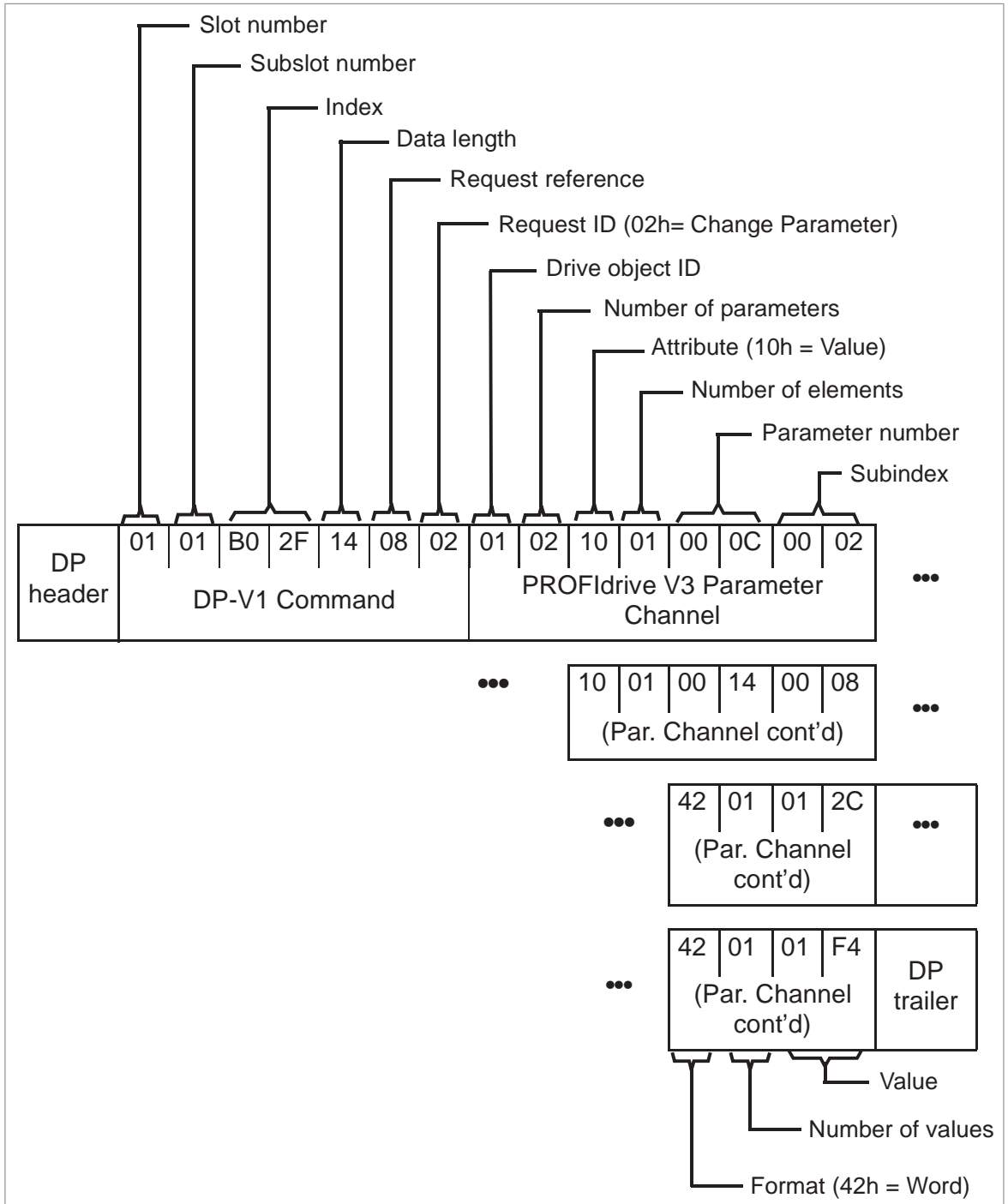

116 PROFINET IO – Communication protocol

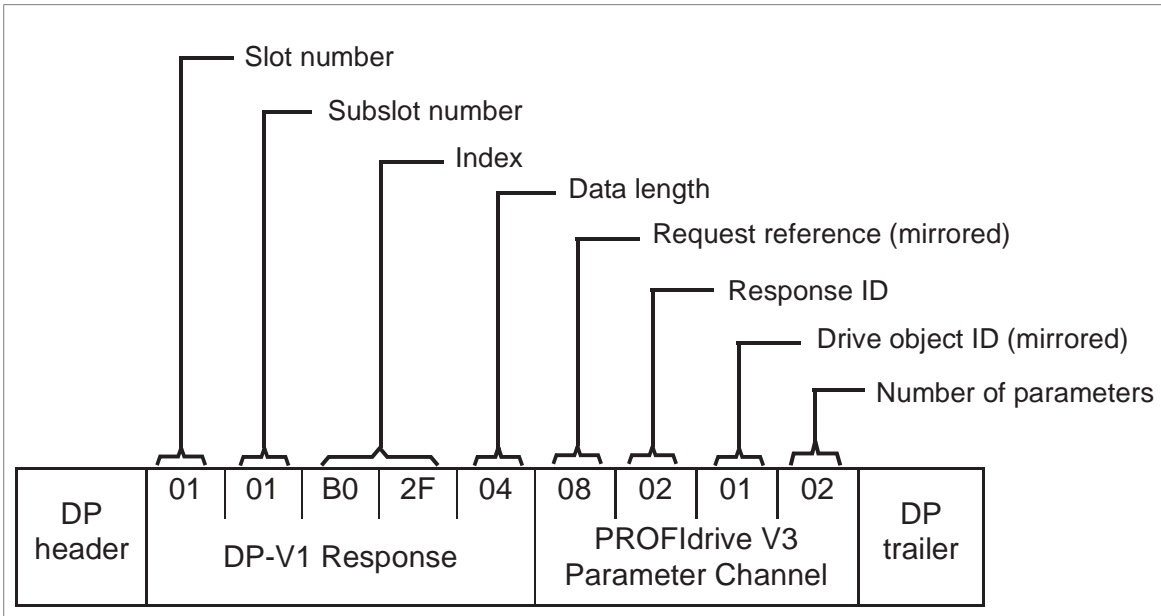

Example 3: Reading a PROFIdrive parameter

In this example, PROFIdrive parameter 919 (397h) is used to read the device system number of the slave, which is the product code of the drive.

- DP-V1 Write request (Reading a PROFIdrive parameter):

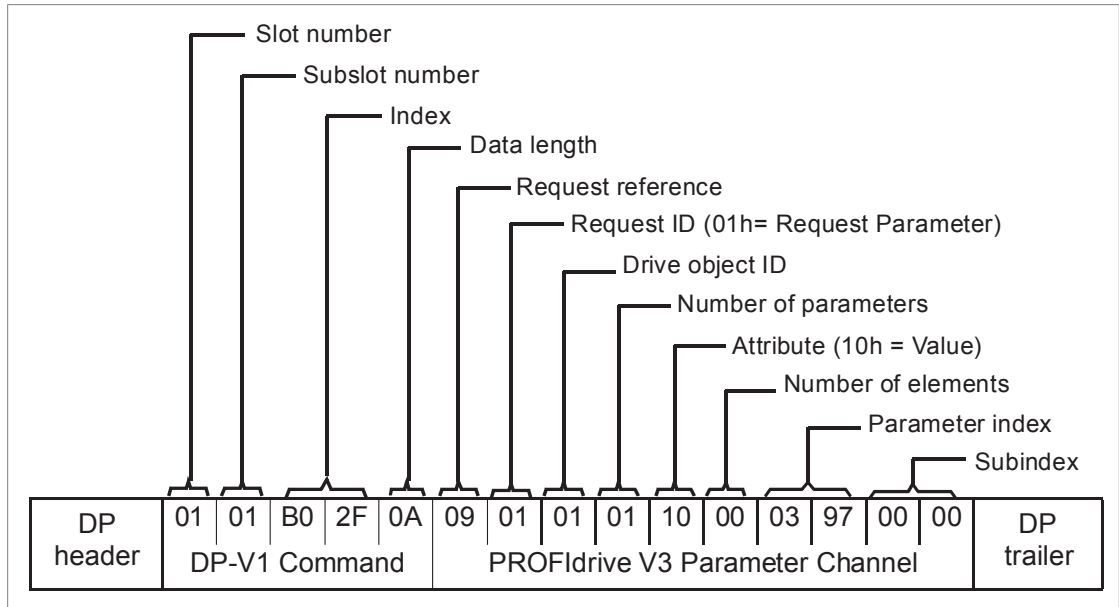

- DP-V1 Read response:

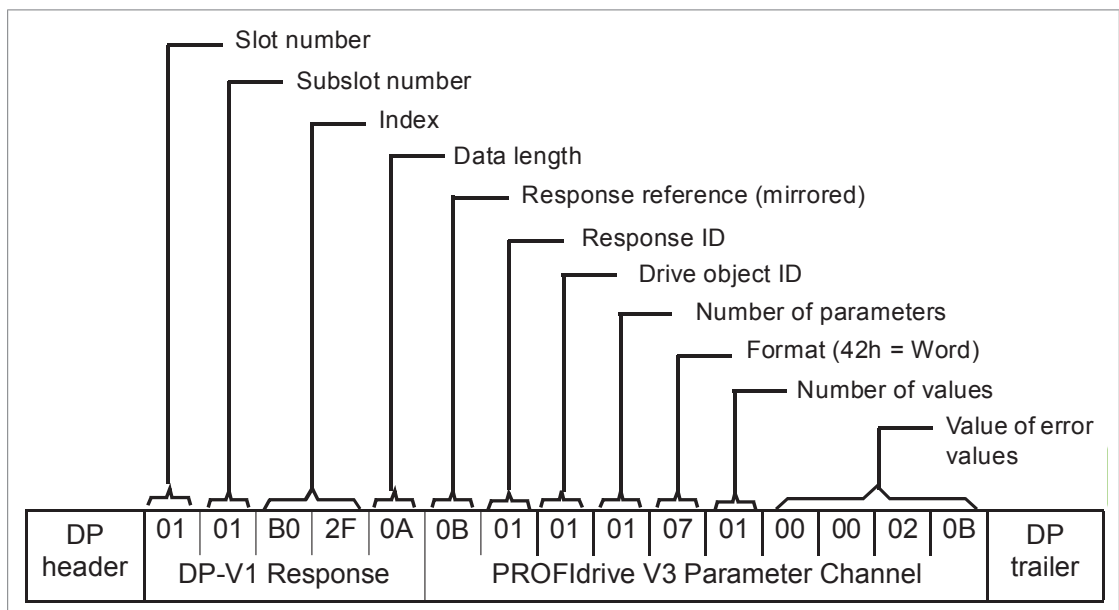

The slave returns the product code of the drive (20Bh in this example).

Example 4: Configuring the process data written to the drive

PROFIdrive parameter 915 (393h) can be used to define which data is written cyclically to a drive parameter as application-specific process data.

In the example below, the value of drive parameter 12.06 (0C.06h) is selected to be taken from PZD3. The parameter will continue to be updated with the contents of PZD3 in each Request frame until a different selection is made.

Subindex (IND) defines which process data word the required data is taken from. *Value* selects the drive parameter to which that word is mapped.

- DP-V1 Write request

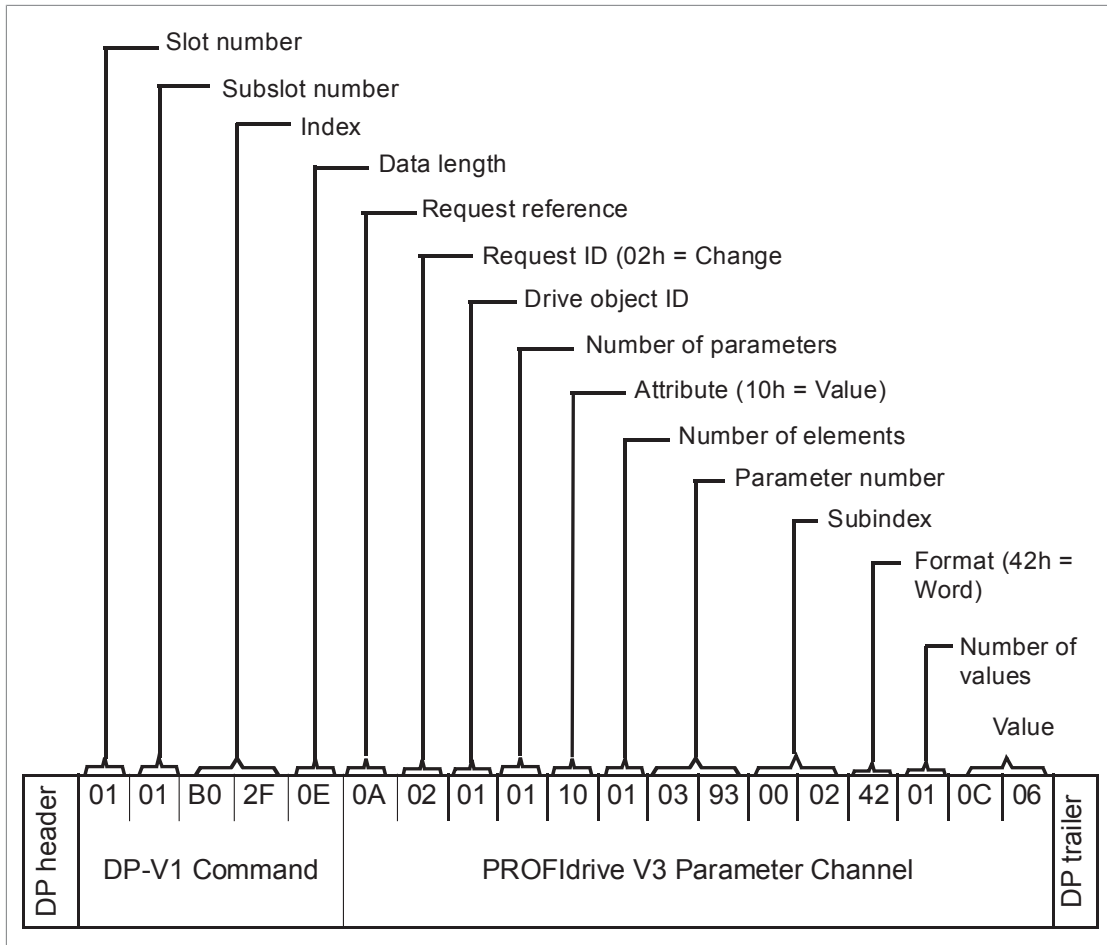

- DP-V1 Read response:

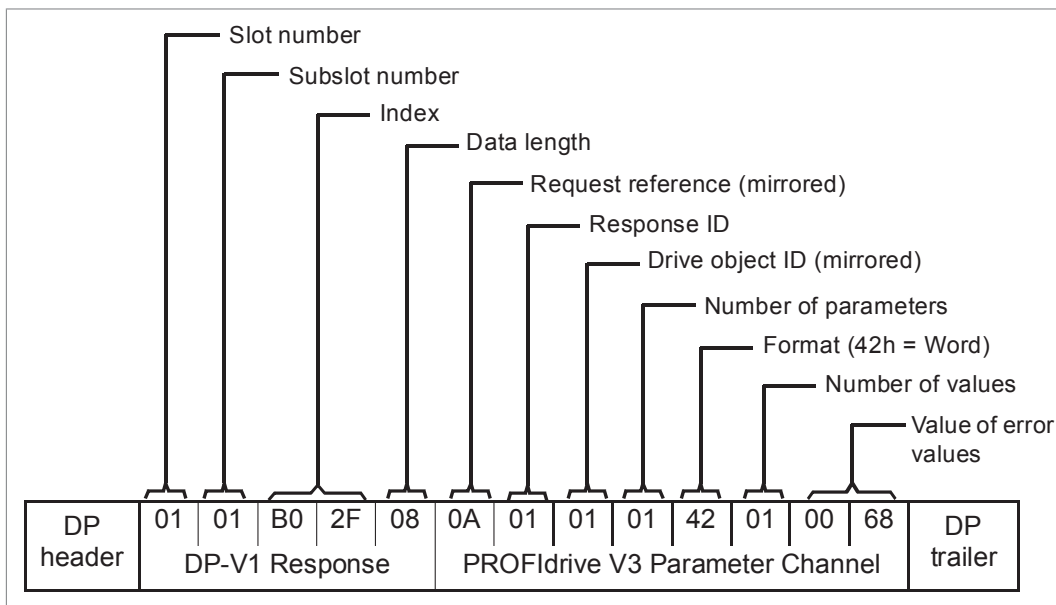

Subsequently, the contents of PZD3 in each Request frame are written to drive parameter 12.06 until a different selection is made.

Example 5: Determining the source of the process data read from the drive

PROFIdrive parameter 916 (394h) can be used to define which data is read cyclically from the drive as application-specific process data. In the example below, the parameter is used to determine which drive parameter the contents of PZD3 are taken from. Subindex (IND) defines which process data word the required data is transmitted in.

- DP-V1 Write request

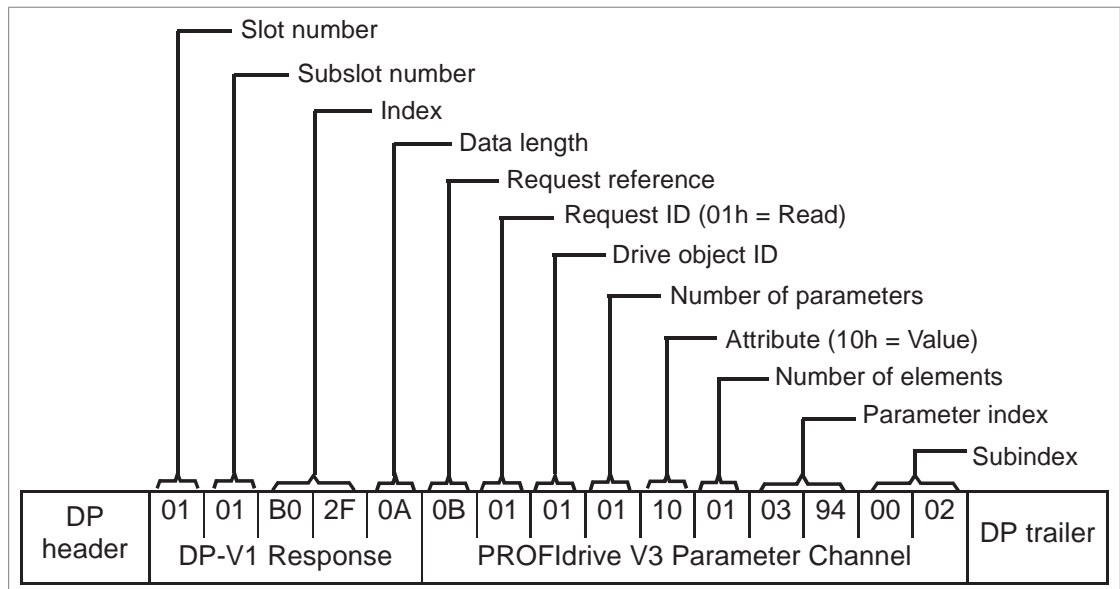

- DP-V1 Read response:

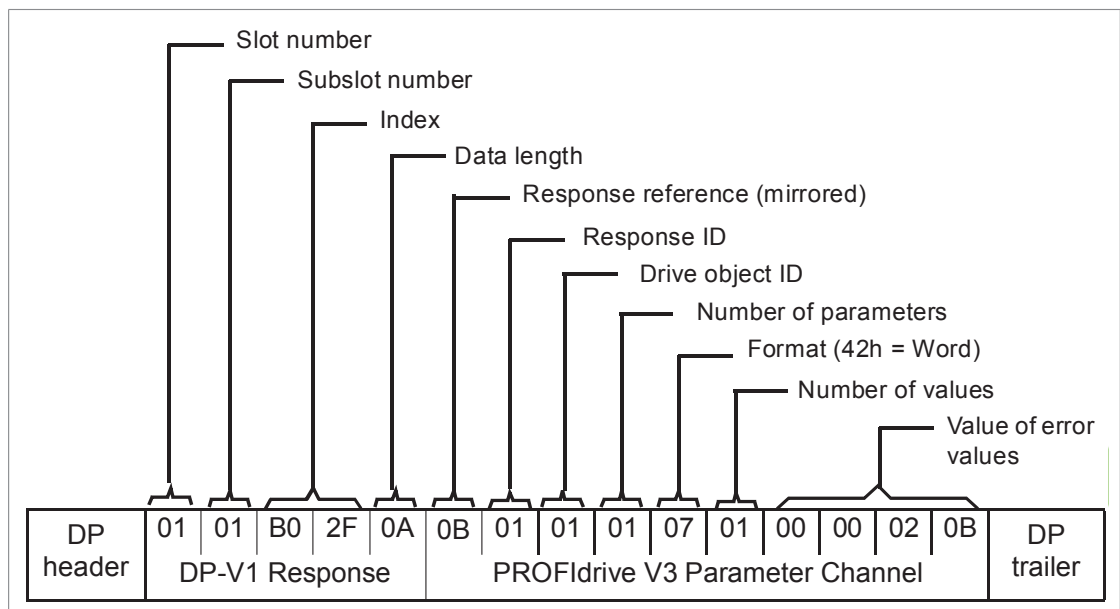

Value indicates the source of PZD3 as drive parameter 12.05 (0C.05h).

Example 6: Reading one element from the parameter description

Note: This example works only with PROFIdrive v4.2 profile.

In the example below, PROFIdrive parameter 965 (3C5h) subindex 2 (length of the string) of parameter description is read.

- DP-V1 Write request:

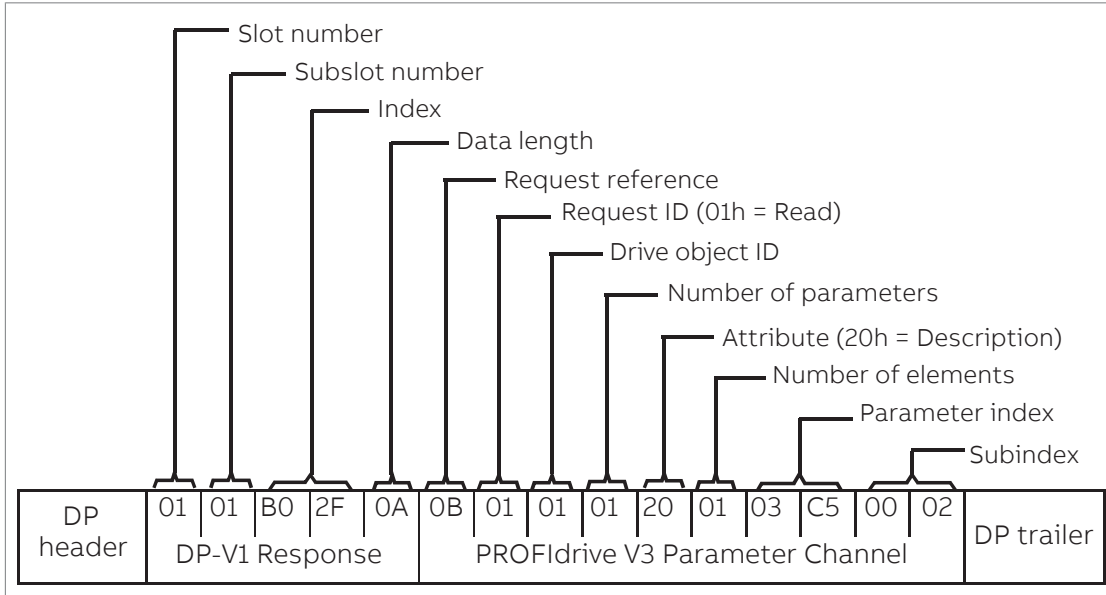

- DP-V1 Read response:

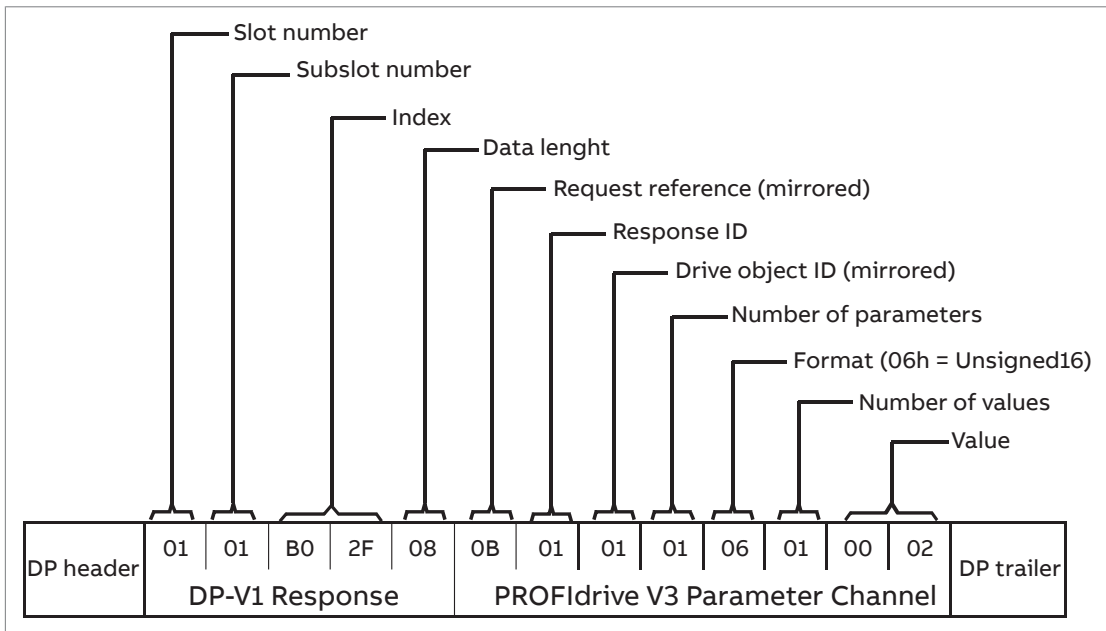

Diagnostic and alarm mechanism

The FPNO-21 module has mechanisms to send alarms and saving diagnostics data to a fault buffer. An alarm is triggered if the host or drive has faults in communication or operation. The alarm and fault buffer mechanisms are enabled by default and can be disabled with a configuration parameter 51.21, refer to [FPNO-21 configuration parameters – group A \(group 1\) \(page 28\)](#).

■ Alarm mechanism

When a fault situation occurs, the adapter module sends an alarm notification, which the master station has to acknowledge. Alarm notifications can be acknowledged, viewed and handled, for example, with Siemens S7 blocks OB82, OB83, OB86 and OB122.

- Block OB82 is used to make sure that the drive does not go to the stop mode during a diagnostic alarm.
- Block OB83 is called if a module is inserted or removed from the system or if the module is modified.
- Block OB86 indicates if there is a failure or event in the distributed periphery.
- Block OB122 is called if the CPU calls a device that is not accessible.

Fault code mapping

An alarm notification contains a fault code, which is called ChannelErrorType. For PROFIdrive API, the drive internal DRIVECOM fault numbers are mapped to PROFIdrive ChannelErrorTypes according to the table below. The fault numbers that are not listed are mapped to ChannelErrorType Other.

ChannelErrorType	Description	DRIVECOM fault numbers
0x9000	Microcontroller hardware or software	4211, 5000, 5401, 5402, 5403, 5484, 5691, 5693, 6100, 6180, 6300, 6306, 6306, 6320, 6481, 6487, 630D, 630F, 64A1, 64A2, 64A3, 64E1, 6581, 65A1, 6682, 6683, 6684, 6881, FF55
0x9001	Mains supply	3291
0x9002	Low voltage supply	3130, 3220
0x9003	DC link overvoltage	3210
0x9004	Power electronics	2211, 2281, 2310, 2312, 2340, 2381, 3180, 3181, 3182, 3183, 3184, 3185, 3186, 3187, 3381, 3385, 5400, 5482, 5682, 5692, FF56
0x9005	Overtemperature electronic device	4110, 4210, 4212, 4290, 4310, 4313, 4981, 7182, 42F1, 4380
0x9006	Earth/ground fault	2330
0x9007	Motor overload	7121
0x9008	Fieldbus system	
0x9009	Safety channel	8182, 8183, 5090, 5091, FA81, FA82, FF7A, FFA0, FFA1, FFA2

ChannelErrorType	Description	DRIVECOM fault numbers
0x900A	Feedback	7301, 7310, 7380, 7381, 7389, 7391, 8480, 8584, 738A, 738B, 738C, 73A0, 73A1
0x900B	Internal communication	5480, 5681, 5690, 7000, 7080, 7081, 7510, 7520, 7540, 7584
0x900C	Infeed	
0x900D	Brake resistor	7111, 7112, 7113, 7181, 7183, 7184, 7185, 7186, 7187, 7191, 71A2, 71A3, 71A5
0x900E	Line filter	
0x900F	External	9000, 9001, 9081, 9082, 9083, 9084, 9085, FF81, FF82, FF8E, FF90
0x9010	Technology	6382
0x9011	Engineering	
0x9012	Other	5080, 5093, 5210, 5300, 6200, 7583, 8110, 8500, 8582, 8583, FF61, FF69, FF6A, FF83, FF84, FF95

■ Fault buffer mechanism

The PROFIdrive profiles have a mechanism that can store eight fault situations to PROFIdrive parameters. Fault and diagnostic data, such as fault numbers and fault codes, can be accessed simultaneously with only one subindex. The mechanism consists of five PROFIdrive parameters:

- PNU944: Fault message counter.
 - Incremented each time the fault buffer changes.
- PNU945: PROFIdrive fault codes presented in the table above.
- PNU946: Fault code list that converts fault numbers to fault codes.
 - Read using the fault number as a subindex to get the corresponding fault code.
- PNU947: Fault numbers according to the DRIVECOM profile.
- PNU950: Size of the fault buffer.

The table below illustrates the structure of a fault buffer. The fault buffer consists of two parameters: fault number (PNU 947) and fault code (PNU 945). The rows of the fault buffer are represented by the parameter subindices. Fault messages are entered into the buffer in the sequence they are detected. Each line in the fault buffer represents a fault message, which is a part of a fault situation. A fault situation lasts from a detection of a fault to its acknowledgement.

Fault situation	PNU947	PNU945	Subindex
	Fault number	Fault code	
Actual fault situation n	0x4210	0x9005	0

Fault situation	PNU947	PNU945	Subindex
	Fault number	Fault code	
Fault situation n-1	0x7510	0x900B	1
Fault situation n-2	0	0	2
Fault situation n-3	0	0	3
Fault situation n-4	0	0	4
Fault situation n-5	0	0	5
Fault situation n-6	0	0	6
Fault situation n-7	0	0	7



PROFINET IO – Diagnostics

Contents of this chapter

This chapter explains how to trace faults with the status LEDs on the adapter module when the module is used for PROFINET IO communication.

Fault and warning messages

For the fault and warning messages concerning the adapter module, refer to the the drive firmware manual.

LEDs

The adapter module has three bicolor diagnostic LEDs. The LEDs are described below.

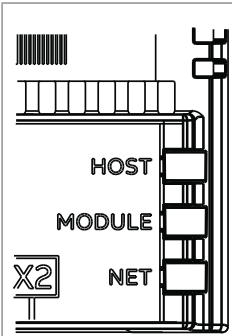

Name	Color	Function
HOST	Flashes green	Establishing communication to the drive
	Green	The connection to the drive operates
	Flashes red	The connection to the drive is temporarily lost
	Flashes orange, alternating with the MODULE flashing orange	Internal file system error. Cycle the drive power off and on. If the error persists, contact your local ABB representative.
MODULE	Off	The device does not have power.
	Flashes orange	Used for identification. The PROFINET master starts to flash the MODULE LED and also flashes the NET LED.
	Flashes green	The device waits for the for PROFINET connection. This can be caused by a missing PROFINET station name or if the PLC does not operate.
	Green	The device operates normally.
	Flashes red (two times per second)	The network link is down. Examine the Ethernet cable connections.
	Flashes red (one time per second)	The mapped data is not fitting to the selected cyclic message type. Examine the group B and C parametrization.
	Red	The Ethernet interface is disabled. Duplicate Address Detection may have detected a duplicate address. Examine the IP configuration and either start a Fieldbus Adapter parameter refresh or cycle the drive power off and on.
	Flashes red-green	The device is in Self Test.
Flashes orange, alternating with the HOST flashing orange	Internal file system error. Cycle the drive power off and on. If the error persists, contact your local ABB representative.	
NETWORK/NET	Off	Device is not on-line. <ul style="list-style-type: none"> • The device has not completed the duplicate address detection yet. • The device may not have power. Look at the MODULE status LED.
	Flashes green	Device is receiving/transmitting on the Ethernet.

10

NONE – Start-up

Contents of this chapter

This chapter contains:

- information on how to configure the drive for operation with the adapter module
- drive-specific instructions on how to start-up the drive with the adapter module
- information on how to configure the client for communication with the adapter module.

Warnings



WARNING!

Obey the safety instructions given in this manual and the drive documentation.

Drive configuration

This information applies to all drive types that are compatible with the adapter module, unless it is otherwise stated.

■ Connection configuration for the NONE protocol

After the adapter module is mechanically and electrically installed according to the instructions in chapters [Mechanical installation](#) and [Electrical installation](#), set the drive for communication with the module.

The detailed procedure of activating the module using the NONE protocol with the drive depends on the drive type. Normally, you must adjust a parameter to activate the communication. Refer to the the drive-specific start-up sections [Starting up fieldbus communication \(page 134\)](#).

When communication between the drive and the adapter module is established, several configuration parameters are copied to the drive. These parameters are shown in the tables below and must be checked first and adjusted if it is necessary. You can adjust the parameters via a drive control panel, a web user interface, or a PC tool.

Note:

- Not all drives show the descriptive names for the configuration parameters.
- The new parameter settings take effect only when you power up the module the next time or when you activate the fieldbus adapter refresh parameter.
- Use the NONE protocol selection when no fieldbus protocol is required. For example, when only the Ethernet tool network is used or to synchronize time.

FPNO-21 configuration parameters – group A (group 1)

Note: The actual parameter group number depends on the drive type. Group A (group 1) corresponds to:

- parameter group 51 in ACS380, ACS480, ACH580, ACQ580 and ACS580.
- parameter group 51 in ACS880 if the adapter is installed as fieldbus adapter A or group 54 if the adapter is installed as fieldbus adapter B.

No.	Name/Value	Description	Default
01	FBA TYPE	Read-only. Shows the fieldbus adapter type as detected by the drive. The value cannot be adjusted by the user. If the value is 0 = None, the communication between the drive and the module has not been established.	132 = PROFINET IO
02	Protocol/Profile	Selects the application protocol and communication profile for the network connection. Select NONE to disable PROFINET protocol. Other services (ABB IP Configuration tool, Ethernet tool network, OPC UA, SNTP, and so on) are still available, refer to Service configuration page (page 161) .	11 = PNIO ABB Pro
	200 = NONE	NONE protocol	
03	Commrate	Sets the bit rate for the Ethernet interface.	0 = Auto
	0 = Auto	Autonegotiate	
	1 = 100 Mbps FD	100 Mbps, full-duplex	
	2 = 100 Mbps HD	100 Mbps, half-duplex	
	3 = 10 Mbps FD	10 Mbps, full-duplex	
	4 = 10 Mbps HD	10 Mbps, half-duplex	
04	IP configuration	Sets the method for configuring the IP address, subnet mask and gateway address for the module.	0 = Static IP
	0 = Static IP	Configuration is obtained from parameters 05...13.	
	1 = Dyn IP DHCP	Configuration is obtained via DHCP.	

No.	Name/Value	Description	Default																																																																				
05 ... 08	IP address 1	An IP address is assigned to each IP node on a network. An IP address is a 32-bit number that is typically represented in “dotted decimal” notation consisting of four decimal integers, on the range 0...255, separated by periods. Each integer represents the value of one octet (8-bits) in the IP address. Parameters define the four octets of the IP address.	0																																																																				
	0...255	IP address																																																																					
																																																																				
	IP address 4	See parameter 05 IP address 1	0																																																																				
	0...255	IP address																																																																					
09	Subnet CIDR	Subnet masks are used for splitting networks into smaller networks called subnets. A subnet mask is a 32-bit binary number that splits the IP address into a network address and host address. Subnet masks are typically represented in either dotted decimal notation or the more compact CIDR notation, as shown in the table below.	0																																																																				
		<table border="1"> <thead> <tr> <th>CIDR</th> <th>Dotted decimal</th> <th>CIDR</th> <th>Dotted decimal</th> </tr> </thead> <tbody> <tr> <td>31</td> <td>255.255.255.254</td> <td>15</td> <td>255.254.0.0</td> </tr> <tr> <td>30</td> <td>255.255.255.252</td> <td>14</td> <td>255.252.0.0</td> </tr> <tr> <td>29</td> <td>255.255.255.248</td> <td>13</td> <td>255.248.0.0</td> </tr> <tr> <td>28</td> <td>255.255.255.240</td> <td>12</td> <td>255.240.0.0</td> </tr> <tr> <td>27</td> <td>255.255.255.224</td> <td>11</td> <td>255.224.0.0</td> </tr> <tr> <td>26</td> <td>255.255.255.192</td> <td>10</td> <td>255.192.0.0</td> </tr> <tr> <td>25</td> <td>255.255.255.128</td> <td>9</td> <td>255.128.0.0</td> </tr> <tr> <td>24</td> <td>255.255.255.0</td> <td>8</td> <td>255.0.0.0</td> </tr> <tr> <td>23</td> <td>255.255.254.0</td> <td>7</td> <td>254.0.0.0</td> </tr> <tr> <td>22</td> <td>255.255.252.0</td> <td>6</td> <td>252.0.0.0</td> </tr> <tr> <td>21</td> <td>255.255.248.0</td> <td>5</td> <td>248.0.0.0</td> </tr> <tr> <td>20</td> <td>255.255.240.0</td> <td>4</td> <td>240.0.0.0</td> </tr> <tr> <td>19</td> <td>255.255.224.0</td> <td>3</td> <td>224.0.0.0</td> </tr> <tr> <td>18</td> <td>255.255.192.0</td> <td>2</td> <td>192.0.0.0</td> </tr> <tr> <td>17</td> <td>255.255.128.0</td> <td>1</td> <td>128.0.0.0</td> </tr> <tr> <td>16</td> <td>255.255.0.0</td> <td></td> <td></td> </tr> </tbody> </table>	CIDR	Dotted decimal	CIDR	Dotted decimal	31	255.255.255.254	15	255.254.0.0	30	255.255.255.252	14	255.252.0.0	29	255.255.255.248	13	255.248.0.0	28	255.255.255.240	12	255.240.0.0	27	255.255.255.224	11	255.224.0.0	26	255.255.255.192	10	255.192.0.0	25	255.255.255.128	9	255.128.0.0	24	255.255.255.0	8	255.0.0.0	23	255.255.254.0	7	254.0.0.0	22	255.255.252.0	6	252.0.0.0	21	255.255.248.0	5	248.0.0.0	20	255.255.240.0	4	240.0.0.0	19	255.255.224.0	3	224.0.0.0	18	255.255.192.0	2	192.0.0.0	17	255.255.128.0	1	128.0.0.0	16	255.255.0.0			
CIDR	Dotted decimal	CIDR	Dotted decimal																																																																				
31	255.255.255.254	15	255.254.0.0																																																																				
30	255.255.255.252	14	255.252.0.0																																																																				
29	255.255.255.248	13	255.248.0.0																																																																				
28	255.255.255.240	12	255.240.0.0																																																																				
27	255.255.255.224	11	255.224.0.0																																																																				
26	255.255.255.192	10	255.192.0.0																																																																				
25	255.255.255.128	9	255.128.0.0																																																																				
24	255.255.255.0	8	255.0.0.0																																																																				
23	255.255.254.0	7	254.0.0.0																																																																				
22	255.255.252.0	6	252.0.0.0																																																																				
21	255.255.248.0	5	248.0.0.0																																																																				
20	255.255.240.0	4	240.0.0.0																																																																				
19	255.255.224.0	3	224.0.0.0																																																																				
18	255.255.192.0	2	192.0.0.0																																																																				
17	255.255.128.0	1	128.0.0.0																																																																				
16	255.255.0.0																																																																						
	1...31	Subnet mask in CIDR notation																																																																					

130 NONE – Start-up

No.	Name/Value	Description	Default
10 ... 13	GW address 1	IP gateways connect individual physical IP subnets into a unified IP network. When an IP node needs to communicate with an IP node on another subnet, the IP node sends the data to the IP gateway for forwarding. Parameters define the four octets of the gateway address.	0
	0...255	GW address	

	GW address 4	See parameter 10 GW address 1.	0
	0.255	GW address	
14	Commrte port 2	Sets the bit rate for the Ethernet port 2.	0 = Auto
	0 = Auto	Autonegotiate	
	1 = 100 Mbps FD	100 Mbps, full-duplex	
	2 = 100 Mbps HD	100 Mbps, half-duplex	
	3 = 10 Mbps FD	10 Mbps, full-duplex	
	4 = 10 Mbps HD	10 Mbps, half-duplex	
	5 = Disable Port	Disable Ethernet port. ABB recommends to disable the second port if it is not in use.	

No.	Name/Value	Description	Default
15	Service configuration	<p>Disable services that are not required.</p> <p>Each service is represented by a single bit. Bit 0, Lock configuration, can be used to prevent accidental changing of this parameter.</p> <p>By default, all services are enabled and configuration is unlocked.</p> <p>ABB recommends to disable all services that are not used after commissioning.</p>	
	Bit	Name	Information
	0	Lock configuration	Changing this bit to one will lock service configuration and no bit can be changed. Only resetting the fieldbus configuration will unlock the parameter. To reset the fieldbus configuration, choose "Reset all fieldbus settings" or "Clear all" in parameter 96.06 Parameter restore.
	1	Disable IP config tool	When this bit is set, access from ABB IP Configuration tool is prevented.
	2	Disable ETH tool network	When this bit is set, access from Ethernet tool network (eg, ABB Drive Composer tool) is prevented.
	3	Disable ping response	When this bit is set, response to ICMP (ping) message is prevented.
	4	Unsecured ETH tool network	When this bit is set, access from Ethernet tool network is unsecured. Note: Drive Composer pro before V2.7 supports unsecured communication only.
	5	Disable configuring web pages	When this bit is set, access to web pages is disabled.
	6	Web-based firmware update	When this bit is set, the web-based firmware update is disabled. The update is enabled as a default.
	7	Disable OPC UA	When this bit is set, the OPC UA server is disabled. OPC UA is not enabled by default. For more information, refer to Appendix E - OPC UA server (page 173) .
8	Unencrypted OPC UA	When this bit is set, connection to the OPC UA server is unencrypted.	
	000000b...111111b	Service configuration	
16 ... 25	Reserved	These parameters are not used by the adapter module when using the NONE protocol.	N/A
26	Reserved	Reserved for web page functionality. For more information, see Appendix C - FPNO-21 configuration web pages (page 155) .	N/A

No.	Name/Value	Description	Default
27	FBA A/B par refresh	Validates any changed adapter module configuration parameter settings. After refreshing, the value reverts automatically to 0 = Done . Note: This parameter cannot be changed while the drive is running.	0 = Done
	0 = Done	Refreshing done	
	1 = Refresh	Refreshing	
28	FBA A/B par table ver	Read-only. Displays the parameter table revision of the fieldbus adapter module mapping file stored in the memory of the drive. In format xyz , where x = major revision number y = minor revision number z = correction number OR in format axyz , where a = major revision number xy = minor revision numbers z = correction number or letter.	N/A
		Parameter table revision	
29	FBA A/B drive type code	Read-only. Displays the drive type code of the fieldbus adapter module mapping file stored in the memory of the drive.	N/A
		Drive type code of the fieldbus adapter module mapping file	
30	FBA A/B mapping file ver	Read-only. Displays the fieldbus adapter module mapping file revision stored in the memory of the drive in decimal format.	N/A
		Mapping file revision	
31	D2FBA A/B comm status	Read-only. Displays the status of the fieldbus adapter module communication. Note: The value names may vary by drive.	0 = Idle or 4 = Offline or 2 = Time out
	0 = Idle	Adapter is not configured.	
	1 = Exec.init	Adapter is initializing.	
	2= Time out	A timeout has occurred in the communication between the adapter and the drive.	
	3= Conf.err	There is an internal error in the communication between the adapter and the drive. Contact your local ABB representative.	
	4 = Off-line	Adapter is off-line.	
	5 = On-line	Adapter is on-line.	
	6 = Reset	Adapter is performing a hardware reset.	

No.	Name/Value	Description	Default
32	FBA A/B comm SW ver	<p>Read-only. Displays patch and build numbers of the adapter module's firmware version in xyy format, where:</p> <p>xx = patch number yy = build number.</p> <p>Example: If the firmware version (<major>.<minor>.<patch>.<build>) is 3.10.200.13, the value C80D is displayed. If the version is 3.10.0.0, the value 0 is displayed.</p> <p>Refer to parameter 33.</p>	N/A
33	FBA A/B appl SW ver	<p>Read-only. Displays major and minor revision numbers of the adapter module's firmware version in xyy format, where:</p> <p>xx = major revision number yy = minor revision number</p> <p>Example: If the firmware version (<major>.<minor>.<patch>.<build>) is 3.10.200.13 or 3.10.0.0, the value 310 is displayed.</p> <p>Refer to parameter 32.</p>	N/A

Starting up fieldbus communication

1. Power up the drive.
 2. To enable communication between the adapter module and the drive, select the correct slot number in parameter 50.01 FBA A enable.
The selection must correspond to the slot where the adapter module is installed. For example, if the adapter module is installed in slot 1, you must select slot 1.
 3. Set the module configuration parameters in group 51.
 - select the communication protocol as NONE (parameter 51.02 = NONE),
 - configure the network settings with parameters 51.03...51.13, and
 - deactivate all services that are not used in the installation with parameter 51.15 Service configuration.
 4. Save the valid parameter values to permanent memory with parameter 96.07 Parameter save manually.
 5. Validate the settings made in parameter groups 51 with parameter 51.27 FBA A par refresh.
-

A large, bold, black number '11' is centered within a light gray rounded square background.

NONE – Diagnostics

Contents of this chapter

This chapter explains how to trace faults with the status LEDs on the adapter module using the NONE protocol.

Fault and warning messages

For the fault and warning messages concerning the adapter module, refer to the drive firmware manual.

LEDs

The adapter module has three bicolor diagnostic LEDs. The LEDs are described below.

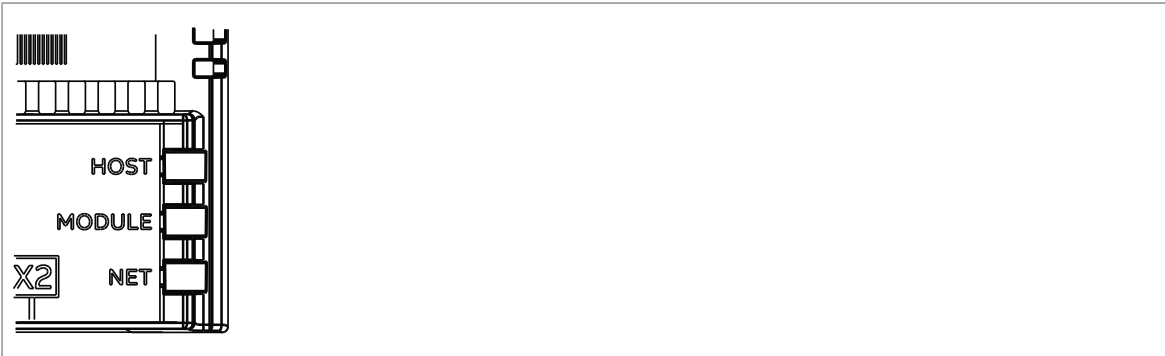

Name	Color	Function
HOST	Flashes green	Establishing communication to the drive
	Green	The connection to the drive operates
	Flashes red	The connection to the drive is temporarily lost
	Flashes orange, alternating with the MODULE flashing orange	Internal file system error. Cycle the drive power off and on. If the error persists, contact your local ABB representative.
MODULE	Off	There is no PC tool connected to the device.
	Flashes orange	The device is attempting to obtain IP configuration from the DHCP server.
	Orange	The device is executing duplicate address detection.
	Green	The PC tool is connected to the device.
	Flashes red	The Ethernet link is down.
	Red	Ethernet interface is disabled. Duplicate address detection may have detected a duplicate address. Examine the IP configuration and either initiate a Fieldbus Adapter parameter refresh or cycle the drive power off and on.
	Flashes orange, alternating with the HOST flashing orange	Internal file system error. Cycle the drive power off and on. If the error persists, contact your local ABB representative.
NETWORK / NET	Off	The Ethernet link is down.
	Flashes green	The Ethernet link is up at 100 Mbps. Flashes to show activity on the interface.
	Flashes orange	The Ethernet link is up at 10 Mbps. Flashes to show activity on the interface.

12

Technical data

Contents of this chapter

This chapter contains the technical specifications of the FPNO-21 module.

Dimension drawing

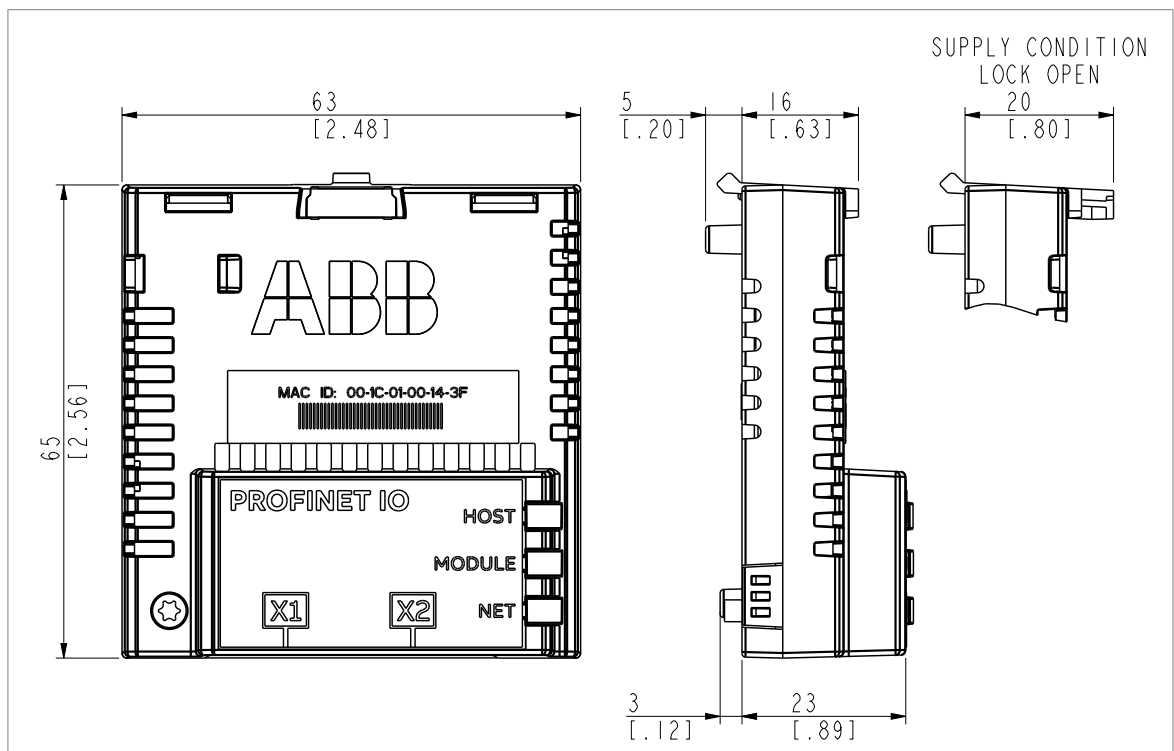

General data

Installation	Into an option slot on the drive control unit
Degree of protection	IP20
Ambient conditions	The applicable ambient conditions specified for the drive in its manuals are in effect.
Package	Cardboard. Plastic wrapping: Antistatic air bubble sheet (PE).
Indicators	Three bicolor LEDs (HOST, MODULE, NETWORK/NET)
Connectors	A 20-pin connector to the drive RJ-45 connector to Ethernet (X1) RJ-45 connector for chaining another adapter module (X2)
Power supply	+3.3 V \pm 5% max. 400 mA (supplied by the drive)
General	Complies with EMC standard EN 61800-3:2004 Printed circuit board conformal coated

Ethernet link

Compatible devices	Ethernet Standard IEEE 802.3 and IEEE 802.3u devices.
Medium	10BASE-TX or 100Base-TX with Auto-negotiation and Auto-MDIX (Auto-crossover) <ul style="list-style-type: none"> • Wiring: CAT5e/6 S/FTP, CAT5e/6 S/STP, CAT5e/6 SF/FTP • Connector: RJ-45 • Termination: Internal • Maximum segment length: 100 m (328 ft)
Topology	Bus, star or ring. A maximum of 50 nodes is permitted for FPNO-21 module in a ring topology. In a chain the maximum recommended number of nodes is 50. More can be used but PROFINET cycle time should be adjusted because of the delays in the network. Each FPNO-21 has an integrated switch which adds 19 μ s forwarding delay for the minimum Ethernet frame. Length of PROFINET cyclic frame FPNO-21 uses is minimum Ethernet frame so 50 nodes will add 1 ms delay for the PROFINET frame.
Transfer rate	10 Mbps or 100 Mbps
Serial communication type	Half-duplex or full-duplex communication
Protocol	PROFINET IO
Number of connections	Three

TCP and UDP service ports

There are multiple in-bound and out-bound network services running on the module. Some ports are protocol-specific and are not used when other protocols are selected.

Port	Service	Purpose
34962 (TCP/UDP)	PROFINET	PROFINET RT Unicast. Note: Used only when PROFINET IO protocol is selected.
34963 (TCP/UDP)	PROFINET	PROFINET RT Multicast. Note: Used only when PROFINET IO protocol is selected.
34964 (TCP/UDP)	PROFINET	PROFINET Context Manager. Note: Used only when PROFINET IO protocol is selected.
80 (TCP)	HTTP	Used for Ethernet tool communication. To disable, go to Service configuration page (page 161) via web interface.
68 (UDP)	DHCP	DHCP client Note: Used only when IP configuration method is selected as "Dyn IP DHCP".
24576 (UDP)	ABB Netconfig	<ul style="list-style-type: none"> • Auto discovery protocol • Used by ControlBuilder plus (IP Configuration tool) and Drive Composer pro and DriveWindow 2.40 PC tools • Discovers ABB-specific Ethernet devices in a local network segment, by listening to and responding to UDP broadcasts. To disable, go to Service configuration page (page 161) via web interface.
161 (UDP)	SNMP	Simple Network Management Protocol (SNMP). Note: Used only when PROFINET IO protocol is selected. To disable, go to Service configuration page (page 161) via web interface.
123 (UDP)	SNTP	Simple Network Time Protocol. This service is disabled by default. To enable the service, go to Service configuration page (page 161) via web interface.
4840 (TCP)	OPC UA	OPC UA server.
443 (TCP)	HTTPS	HTTPS protocol, used for access to FPNO-21's web page and for Ethernet tool Network (like Drive Composer pro).



13

Appendix A – PROFIdrive parameters and I&M records of PROFINET IO

Contents of this chapter

This chapter contains:

- PROFIdrive parameters of the PROFINET IO communication protocol
- telegram and response structures for the I&M (Identification & Maintenance) records of the PROFINET IO communication protocol.

PROFIdrive parameters

Par. no.	R/W ¹⁾	Data type	Description
915	R/W	Array [12] Unsigned16	Assignment PZD1 to PZD12 in PPO-write Note: this parameter is not available with PROFIdrive v4.2 profile.
916	R/W	Array [12] Unsigned16	Assignment PZD1 to PZD12 in PPO-read Note: this parameter is not available with PROFIdrive v4.2 profile.
919	R	Unsigned32	Device system number Note: this parameter is not available with PROFIdrive v4.2 profile.
922	R	Unsigned16	Telegram selection

142 Appendix A – PROFIdrive parameters and I&M records of PROFINET IO

Par. no.	R/W ¹⁾	Data type	Description																																
923	R	Array [n] Unsigned16	List of all parameters for signals. Mandatory if process data normalization is used and/or parameters 915 and 916 are implemented.																																
			<table border="1"> <thead> <tr> <th>Signal no. and name</th> <th>Type</th> </tr> </thead> <tbody> <tr> <td>1 – Control word 1 (STW1)</td> <td>Unsigned16</td> </tr> <tr> <td>2 – Status word 1 (ZSW1)</td> <td>Unsigned16</td> </tr> <tr> <td>3 – Control word 2 (STW2)</td> <td>Unsigned16</td> </tr> <tr> <td>4 – Status word 2 (ZSW2)</td> <td>Unsigned16</td> </tr> <tr> <td>5 – Speed set point A (NSOLL_A)</td> <td>Signed16</td> </tr> <tr> <td>6 – Speed actual value A (NIST_A)</td> <td>Signed16</td> </tr> <tr> <td>7 – Speed set point B (NSOLL_B)</td> <td>Signed32</td> </tr> <tr> <td>8 – Speed actual value B (NIST_B)</td> <td>Signed32</td> </tr> <tr> <td>27 – Position set point A (XSOLL_A)</td> <td>Signed32</td> </tr> <tr> <td>28 – Position actual value A (XIST_A)</td> <td>Signed32</td> </tr> <tr> <td>32 – Traversing block selection (SATZANW) (not supported)</td> <td>Unsigned16</td> </tr> <tr> <td>33 – Actual traversing block (AKT-SATZ) (not supported)</td> <td>Unsigned16</td> </tr> <tr> <td>34 – Target position (TARPOS_A) (not supported)</td> <td>Signed32</td> </tr> <tr> <td>35 – Velocity (VELOCITY_A)</td> <td>Unsigned32</td> </tr> <tr> <td>101...9999 – Drive-specific</td> <td>–</td> </tr> </tbody> </table>	Signal no. and name	Type	1 – Control word 1 (STW1)	Unsigned16	2 – Status word 1 (ZSW1)	Unsigned16	3 – Control word 2 (STW2)	Unsigned16	4 – Status word 2 (ZSW2)	Unsigned16	5 – Speed set point A (NSOLL_A)	Signed16	6 – Speed actual value A (NIST_A)	Signed16	7 – Speed set point B (NSOLL_B)	Signed32	8 – Speed actual value B (NIST_B)	Signed32	27 – Position set point A (XSOLL_A)	Signed32	28 – Position actual value A (XIST_A)	Signed32	32 – Traversing block selection (SATZANW) (not supported)	Unsigned16	33 – Actual traversing block (AKT-SATZ) (not supported)	Unsigned16	34 – Target position (TARPOS_A) (not supported)	Signed32	35 – Velocity (VELOCITY_A)	Unsigned32	101...9999 – Drive-specific	–
			Signal no. and name	Type																															
			1 – Control word 1 (STW1)	Unsigned16																															
			2 – Status word 1 (ZSW1)	Unsigned16																															
			3 – Control word 2 (STW2)	Unsigned16																															
			4 – Status word 2 (ZSW2)	Unsigned16																															
			5 – Speed set point A (NSOLL_A)	Signed16																															
			6 – Speed actual value A (NIST_A)	Signed16																															
			7 – Speed set point B (NSOLL_B)	Signed32																															
			8 – Speed actual value B (NIST_B)	Signed32																															
			27 – Position set point A (XSOLL_A)	Signed32																															
			28 – Position actual value A (XIST_A)	Signed32																															
			32 – Traversing block selection (SATZANW) (not supported)	Unsigned16																															
			33 – Actual traversing block (AKT-SATZ) (not supported)	Unsigned16																															
34 – Target position (TARPOS_A) (not supported)	Signed32																																		
35 – Velocity (VELOCITY_A)	Unsigned32																																		
101...9999 – Drive-specific	–																																		
			Note: this parameter is not available with PROFIdrive v4.2 profile.																																
927	R/W	Unsigned16	Operator control rights (parameter identification, PKW)																																
			<table border="1"> <thead> <tr> <th>Value</th> <th>Mode</th> </tr> </thead> <tbody> <tr> <td>0</td> <td>Parameters cannot be written, only read (927 can be written).</td> </tr> <tr> <td>1</td> <td>Parameters can be written and read (default).</td> </tr> </tbody> </table>	Value	Mode	0	Parameters cannot be written, only read (927 can be written).	1	Parameters can be written and read (default).																										
			Value	Mode																															
0	Parameters cannot be written, only read (927 can be written).																																		
1	Parameters can be written and read (default).																																		
928	R/W	Unsigned16	Control rights (process data, PZD).																																
			<table border="1"> <thead> <tr> <th>Value</th> <th>Mode</th> </tr> </thead> <tbody> <tr> <td>0</td> <td>PZD part is disabled, that is, receipt of new PZD data is ignored.</td> </tr> <tr> <td>1</td> <td>PZD part is enabled (default).</td> </tr> </tbody> </table>	Value	Mode	0	PZD part is disabled, that is, receipt of new PZD data is ignored.	1	PZD part is enabled (default).																										
			Value	Mode																															
0	PZD part is disabled, that is, receipt of new PZD data is ignored.																																		
1	PZD part is enabled (default).																																		

Par. no.	R/W ¹⁾	Data type	Description	
929	R	Unsigned16	Selected PPO type	
			Value	PPO type
			1	PPO1
			2	PPO2
			3	PPO3
			4	PPO4
			5	PPO5
			6	PPO6
			7	PPO7
			Note: This parameter is not available if Standard telegram ST1 or ST2 is selected.	
Note: This parameter is not available with PROFIdrive v4.2 profile.				
930	R/W	Unsigned16	Selection switch for communication profile.	
			Behavior when PROFIdrive v.4.2 is active:	
			Value	Mode
			1	PROFIdrive v4.2
			8001h	ABB Drives
			8002h	Transparent 16
			8003h	Transparent 32
			8004h	PROFIdrive positioning mode
			8005h	PROFIdrive
			Behavior when any other profile is active:	
			Value	Mode
			1	PROFIdrive
			8001h	ABB Drives
			8002h	Transparent 16
			8003h	Transparent 32
			8004h	PROFIdrive positioning mode
8005h	PROFIdrive v4.2			
933	R/W	Unsigned16	Selection switch for Control word, bit 11.	
			Value	Module Control with bit
			0	None
			1 to 5	Vendor-specific 1 to 5 ²⁾
			Note: This parameter is not available with PROFIdrive v4.2 profile.	
934	R/W	Unsigned16	Selection switch for Control word, bit 12. (See parameter 933 for coding.)	
			Note: This parameter is not available with PROFIdrive v4.2 profile.	

144 Appendix A – PROFIdrive parameters and I&M records of PROFINET IO

Par. no.	R/W ¹⁾	Data type	Description																		
935	R/W	Unsigned16	Selection switch for Control word, bit 13. (See parameter 933 for coding.) Note: This parameter is not available with PROFIdrive v4.2 profile.																		
936	R/W	Unsigned16	Selection switch for Control word, bit 14. (See parameter 933 for coding.) Note: This parameter is not available with PROFIdrive v4.2 profile.																		
937	R/W	Unsigned16	Selection switch for Control word, bit 15. (See parameter 933 for coding.) Note: This parameter is not available with PROFIdrive v4.2 profile.																		
939	R/W	Unsigned16	Selection switch for Status word, bit 11. <table border="1" data-bbox="667 734 1299 869"> <thead> <tr> <th>Value</th> <th>Module Status word bit</th> </tr> </thead> <tbody> <tr> <td>0</td> <td>None</td> </tr> <tr> <td>1 to 4</td> <td>Vendor-specific 1 to 4²⁾</td> </tr> </tbody> </table> Note: This parameter is not available with PROFIdrive v4.2 profile.	Value	Module Status word bit	0	None	1 to 4	Vendor-specific 1 to 4 ²⁾												
Value	Module Status word bit																				
0	None																				
1 to 4	Vendor-specific 1 to 4 ²⁾																				
940	R/W	Unsigned16	Selection switch for Status word, bit 12. (See parameter 939 for coding.) Note: This parameter is not available with PROFIdrive v4.2 profile.																		
941	R/W	Unsigned16	Selection switch for Status word, bit 13. (See parameter 939 for coding.) Note: This parameter is not available with PROFIdrive v4.2 profile.																		
942	R/W	Unsigned16	Selection switch for Status word, bit 14. (See parameter 939 for coding.) Note: This parameter is not available with PROFIdrive v4.2 profile.																		
943	R/W	Unsigned16	Selection switch for Status word, bit 15. (See parameter 939 for coding.) Note: This parameter is not available with PROFIdrive v4.2 profile.																		
944	R	Unsigned16	Fault message counter																		
945	R	Array[64] Unsigned16	Fault code (Channel Error Type) <table border="1" data-bbox="667 1630 1299 2056"> <thead> <tr> <th>Sub-index</th> <th>Contents</th> </tr> </thead> <tbody> <tr> <td>0</td> <td>Last fault</td> </tr> <tr> <td>8</td> <td>Second last ackn. fault</td> </tr> <tr> <td>16</td> <td>Third last ackn. fault</td> </tr> <tr> <td>24</td> <td>Fourth last ackn. fault</td> </tr> <tr> <td>32</td> <td>Fifth last ackn. fault</td> </tr> <tr> <td>40</td> <td>Sixth last ackn. fault</td> </tr> <tr> <td>48</td> <td>Seventh last ackn. fault</td> </tr> <tr> <td>56</td> <td>Eighth last ackn. fault</td> </tr> </tbody> </table>	Sub-index	Contents	0	Last fault	8	Second last ackn. fault	16	Third last ackn. fault	24	Fourth last ackn. fault	32	Fifth last ackn. fault	40	Sixth last ackn. fault	48	Seventh last ackn. fault	56	Eighth last ackn. fault
Sub-index	Contents																				
0	Last fault																				
8	Second last ackn. fault																				
16	Third last ackn. fault																				
24	Fourth last ackn. fault																				
32	Fifth last ackn. fault																				
40	Sixth last ackn. fault																				
48	Seventh last ackn. fault																				
56	Eighth last ackn. fault																				

Appendix A – PROFIdrive parameters and I&M records of PROFINET IO 145

Par. no.	R/W ¹⁾	Data type	Description														
946	R	Array [n] Unsigned16	Fault code list. Contains the mapping between DRIVECOM fault codes and Channel Error Types. If you use a DRIVECOM fault code as an index when reading PNU946, the corresponding Channel Error Type is returned.														
947	R	Array [64] Unsigned16	Fault number (coded according to the DRIVECOM profile). <table border="1" style="width: 100%; border-collapse: collapse;"> <thead> <tr> <th style="width: 50%;">Subindex</th> <th style="width: 50%;">Contents</th> </tr> </thead> <tbody> <tr> <td colspan="2">See parameter 945.</td> </tr> </tbody> </table>	Subindex	Contents	See parameter 945 .											
Subindex	Contents																
See parameter 945 .																	
950	R	Array [2] Unsigned16	Size of the fault buffer <table border="1" style="width: 100%; border-collapse: collapse;"> <thead> <tr> <th style="width: 20%;">Sub-index</th> <th style="width: 80%;">Contents</th> </tr> </thead> <tbody> <tr> <td>0</td> <td>Amount of fault situations</td> </tr> <tr> <td>1</td> <td>Amount of fault messages</td> </tr> </tbody> </table>	Sub-index	Contents	0	Amount of fault situations	1	Amount of fault messages								
Sub-index	Contents																
0	Amount of fault situations																
1	Amount of fault messages																
953	R	Unsigned16	Last alarm ³⁾														
954	R	Unsigned16	Second last alarm ³⁾														
955	R	Unsigned16	Third last alarm ³⁾														
956	R	Unsigned16	Fourth last alarm ³⁾														
957	R	Unsigned16	Fifth last alarm ³⁾														
964	R	Array [6] Unsigned16	<table border="1" style="width: 100%; border-collapse: collapse;"> <thead> <tr> <th style="width: 15%;">Sub-index</th> <th style="width: 85%;">Contents</th> </tr> </thead> <tbody> <tr> <td>0</td> <td>Manufacturer</td> </tr> <tr> <td>1</td> <td>Device type</td> </tr> <tr> <td>2</td> <td>Version</td> </tr> <tr> <td>3</td> <td>Firmware date (year)</td> </tr> <tr> <td>4</td> <td>Firmware date (day/month)</td> </tr> <tr> <td>5</td> <td>Number of Axes</td> </tr> </tbody> </table>	Sub-index	Contents	0	Manufacturer	1	Device type	2	Version	3	Firmware date (year)	4	Firmware date (day/month)	5	Number of Axes
Sub-index	Contents																
0	Manufacturer																
1	Device type																
2	Version																
3	Firmware date (year)																
4	Firmware date (day/month)																
5	Number of Axes																
965	R	Octet String2	Profile number of this device. Eg: 0302h = Profile 3, Version 2														
967	R	V2	Control word (CW)														
968	R	V2	Status word (SW)														
970	R/W	Unsigned16	Load parameter record <table border="1" style="width: 100%; border-collapse: collapse;"> <thead> <tr> <th style="width: 20%;">Value</th> <th style="width: 80%;">Description</th> </tr> </thead> <tbody> <tr> <td>0</td> <td>No action</td> </tr> <tr> <td>1</td> <td>Restore factory settings</td> </tr> </tbody> </table> <p>The parameter must do a zero-to-one transition and the motor must be stopped.</p>	Value	Description	0	No action	1	Restore factory settings								
Value	Description																
0	No action																
1	Restore factory settings																

146 Appendix A – PROFIdrive parameters and I&M records of PROFINET IO

Par. no.	R/W ¹⁾	Data type	Description	
971	R/W	Unsigned16	Save parameter record	
			Value	Description
			0	No action
			1	Save the drive parameters to non-volatile memory
			The parameter must do a zero-to-one transition and the motor must be stopped. Note: This parameter is not available with PROFIdrive v4.2 profile.	
972	R/W	Unsigned16	Software reset	
			Value	Description
			0	No action
			1	Re-boot PROFINET module
			The parameter must do a zero-to-one transition and the motor must be stopped.	
975	R	Array[n] Unsigned16	DO identification. For subindexes 0...4, see parameter 964 .	
			Sub-index	Meaning
			5	Value 2 = Axis
			6	PROFIdrive DO sub class 1
			7	Drive Object ID
980 981	R	Array[n] Unsigned16	Number list of defined parameters. If the subindex is 0, the end of the list has been reached. If the subindex is the number of the next list parameter, the list is continued there. Note: The value returned from this parameter is different in PROFIdrive v4.2 and PROFIdrive profiles. This is because the profiles have differences in their available parameters.	
1000	R/W	Unsigned16	Map 16-bit selection ³⁾ . Used to request the data type for mapped parameters if mapping is done with parameter 915 or 916.	
			Value	Description
			1	User 16-bit mapping, if available.
1001	R/W	Integer16	SNTP time offset to UTC time.	
			Value	Description
			-1440, 1440	Time in minutes to offset the UTC time received from SNTP
50000	R/W	Unsigned16	Disable alarms.	
			Value	Description
			0	PNIO alarms enabled
			1	PNIO alarms disabled

Par. no.	R/W ¹⁾	Data type	Description
60000	R/W	Float32	Velocity reference scaling value
61000	R	OctetString[240]	Name of station
61001	R	OctetString[4]	IP of station
61002	R	OctetString[6]	MAC address of station
61003	R	OctetString[4]	Default gateway of station
61004	R	OctetString[4]	Subnet mask of station

1) Read and/or Write

2) The meaning of vendor-specific bits is defined by the drive control program.

3) Support depends on the drive type.

PROFIdrive parameter descriptions

PROFIdrive v4.2 profile supports parameter descriptions for the PROFIdrive parameters. Parameter descriptions can be read using DP-V1 Write request with Attribute (20h = Description).

Subindex	Data type	Description
0	OctetString[46]	Complete description
1	V2	Identifier (ID)
2	Unsigned16	Number of array elements or length of string
3	Floating Point	Standardization factor
4	OctetString[2]	Variable attribute
5	OctetString[4]	Reserved
6	VisibleString16	Name
7	OctetString[4]	Low limit
8	OctetString[4]	High limit
9	OctetString[2]	Reserved
10	V2	ID extension
11	Unsigned16	DO IO DATA reference parameter
12	V2	DO IO DATA normalization

The table below shows the parameter description element "Identifier (ID)":

Bit	Description
0 to 7	Numeric identifier of the parameter value's data type
8	Standardization factor and variable attribute not relevant. This bit is set if parameters have data types to which physical values may not be calculated, for example the data type string.
9	Parameter not writable

Bit	Description
10	Additional text array available
11	Reserved
12	Parameter was changed with respect to the factory setting. This bit is set if the parameter value is unequal to the factory setting.
13	Parameter value may be reset only. If this bit is set, the associated parameter value is increased exclusively by internal processing, while externally, it may only be set to "0".
14	Array
15	Reserved

I&M records

I&M (Identification & Maintenance) records can be read, for example, with the DTM tool. The FPNO-21 module supports the mandatory I&M0 record as well as the optional I&M1, I&M2, I&M3, and I&M4 records.

■ Call-REQ-PDU telegram for read/write access to I&M records

Function	Record Data Index
I&M0	0xAFF0
I&M1	0xAFF1
I&M2	0xAFF2
I&M3	0xAFF3
I&M4	0xAFF4

■ Response structure for I&M0 (Read-only)

	Contents	Size	Coding
Header		10 Octets	–
I&M block	MANUFACTURER_ID	2 Octets	0x1A = ABB Automation
	ORDER_ID	20 Octets	6438177508335 = EAN code for FPNO-21 kit
	SERIAL_NUMBER	16 Octets	Serial number of FPNO-21 module
	HARDWARE_REVISION	2 Octets	Hardware version of FPNO-21 module
	SOFTWARE_REVISION	4 Octets	Format: V255.255.255 Eg, V1.0.0 = software version 100
	REVISION_COUNTER	2 Octets	(Marks a change of hardware or its parameters)
	PROFILE_ID	2 Octets	3A00 (...3AFF) PROFIdrive
	PROFILE_SPECIFIC_TYPE	2 Octets	0 = no specific type
	IM_VERSION	2 Octets	0x0101 = version 1.1
	IM_SUPPORTED	2 Octets	30 = I&M0, I&M1, I&M2, I&M3 and I&M4 supported

■ Response structure for I&M1 (Read/Write)

	Contents	Size	Coding
Header		10 Octets	–
I&M block	TAG_FUNCTION	32 Octets	Device function or task
	TAG_LOCATION	22 Octets	Device location

■ Response structure for I&M2 (Read/Write)

	Contents	Size	Coding
Header		10 Octets	–
I&M block	INSTALLATION_DATE	16 Octets	Installation date. Eg, 2011-01-01 16:23
	RESERVED	38 Octets	Reserved

Note: I&M1, I&M2 and I&M3 are blank (0x20) by default.

■ Response structure for I&M3 (Read/Write)

	Contents	Size	Coding
Header		10 Octets	–

	Contents	Size	Coding
I&M block	DESCRIPTOR	54 Octets	Description of the device set by the user

■ Response structure for I&M4 (Read/Write)

I&M4 is read-only and shows the PROFIsafe configuration CRC.

	Contents	Size	Coding
Header		10 Octets	–
I&M block	SIGNATURE	54 Octets	Security code for identifying sessions and changes

Note: I&M4 is filled with zeros (0x0) by default.

Drive information

The FPNO-21 module enables the retrieval of drive-specific information through the reading of PROFINET records.

Record data index	Description
0x03f0	Drive type
0x03f1	Drive application
0x03f2	Drive firmware version
0x03f3	Drive serial number

14

Appendix B – ABB IP configuration tool

Contents of this chapter

This chapter shows how to use the ABB IP configuration tool to:

- find configured and unconfigured FPNO-21 adapter modules in the network
- rewrite the IP configuration of the adapter modules.

Installation

The ABB IP configuration tool is part of the ABB Automation Builder software. No separate installation is needed.

Finding adapter modules in the network

1. Open the ABB IP configuration tool.
2. Click the **Scan** button.

The FPNO-21 adapter modules in the network are shown in the results list.

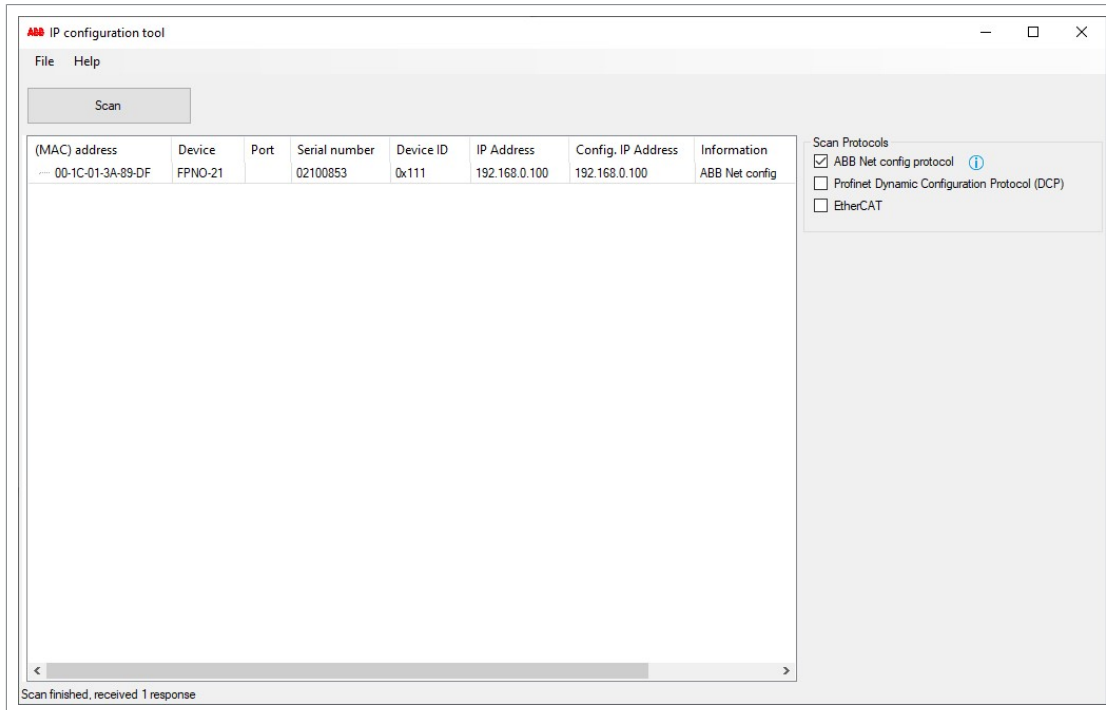

Rewriting the IP configuration of adapter modules

1. Scan the network for adapter modules.
For instructions, refer to section [Finding adapter modules in the network \(page 151\)](#).
2. In the results list, select the adapter module.

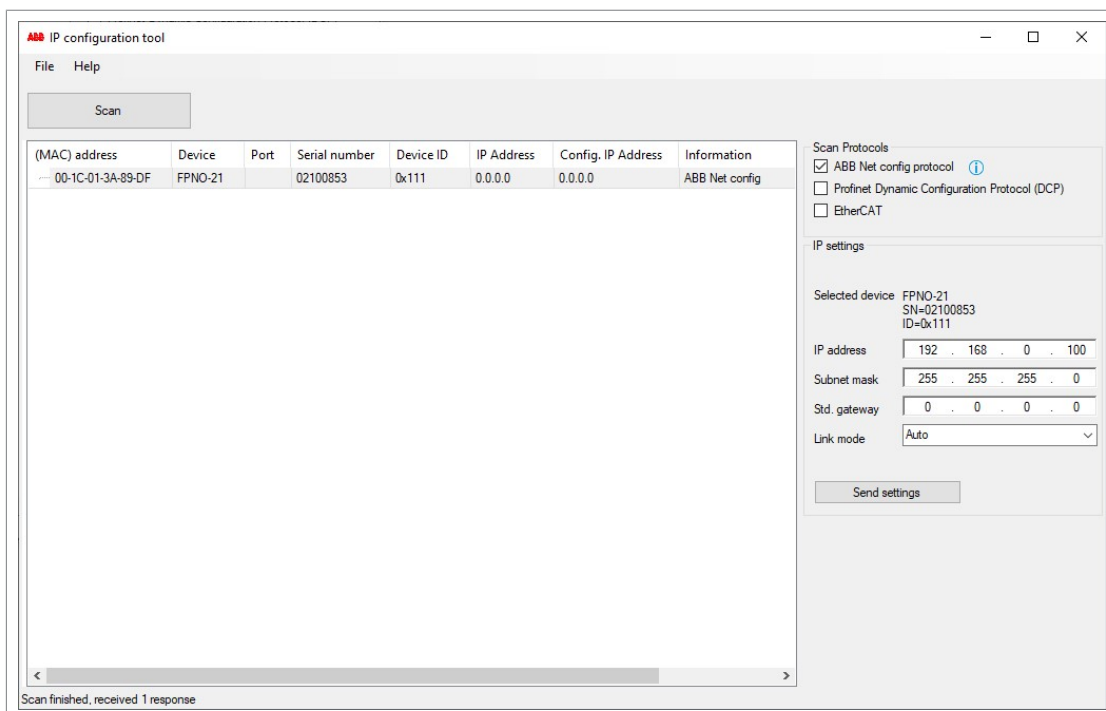

3. Below **IP settings**, define the IP configuration settings according to your network configuration.
4. To apply the new settings, click the **Send settings** button.

The new current IP address and configured IP address appear on the results list.

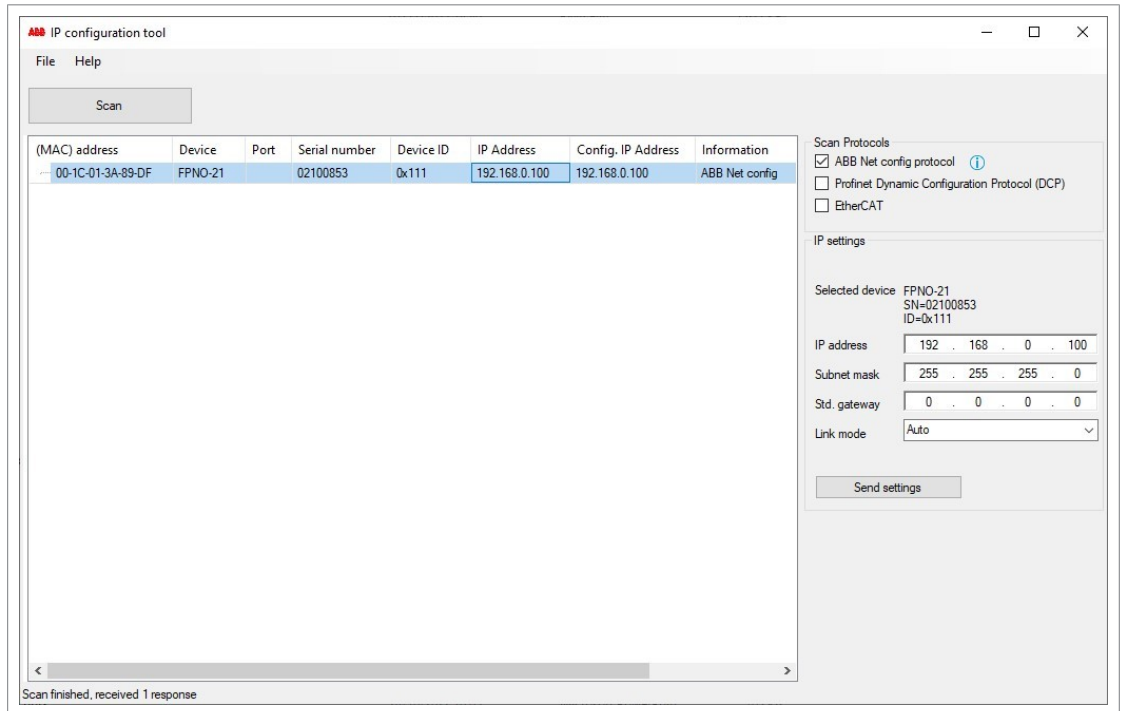

15

Appendix C - FPNO-21 configuration web pages

Contents of this chapter

This chapter presents the FPNO-21 configuration web pages.

Note: ABB recommends to disable the web pages after the commissioning to reduce cyber security risks. Refer to [Service configuration page \(page 161\)](#).

Browser requirements

You can use any web browser.

Compatibility

The web pages support all drives compatible with the FPNO-21 adapter module.
For the compatibility table, refer to [Drives \(page 13\)](#).

Logging in

1. Open a web browser and type the IP address of the adapter module in the address field. The IP address is visible in the FPNO-21 configuration parameters, group A, parameter 5...8.

Example: <https://192.168.0.100/>

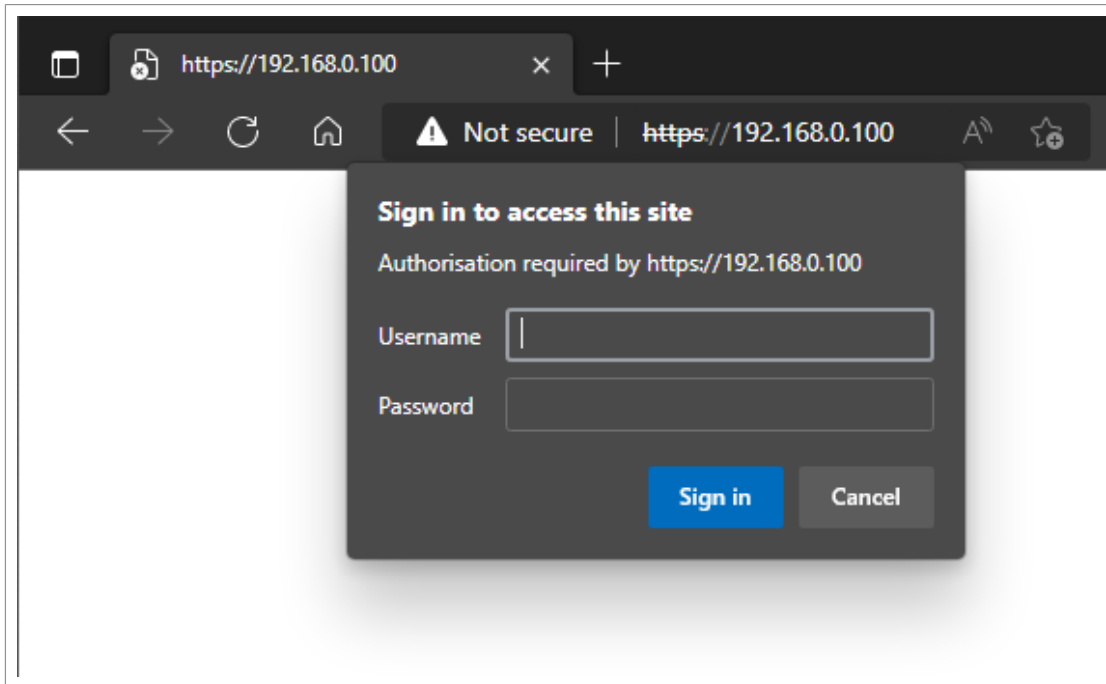

2. Log in with a user name and a password.
Default user name: admin
Password: The last six digits of the MAC address of the adapter module, in upper case, without hyphens.
The MAC ID is visible on the cover of the adapter module and in the ABB IP configuration tool, refer to [Appendix B – ABB IP configuration tool \(page 151\)](#).
Example: If the MAC address of the adapter module is 00-1C-01-00-2F-73, the password is 002F73.
The browser opens the user interface.
3. After successful login, you are prompted to change the password for security reasons. ABB recommends that you change the default password. For the password restrictions, refer to [Password page \(page 165\)](#).

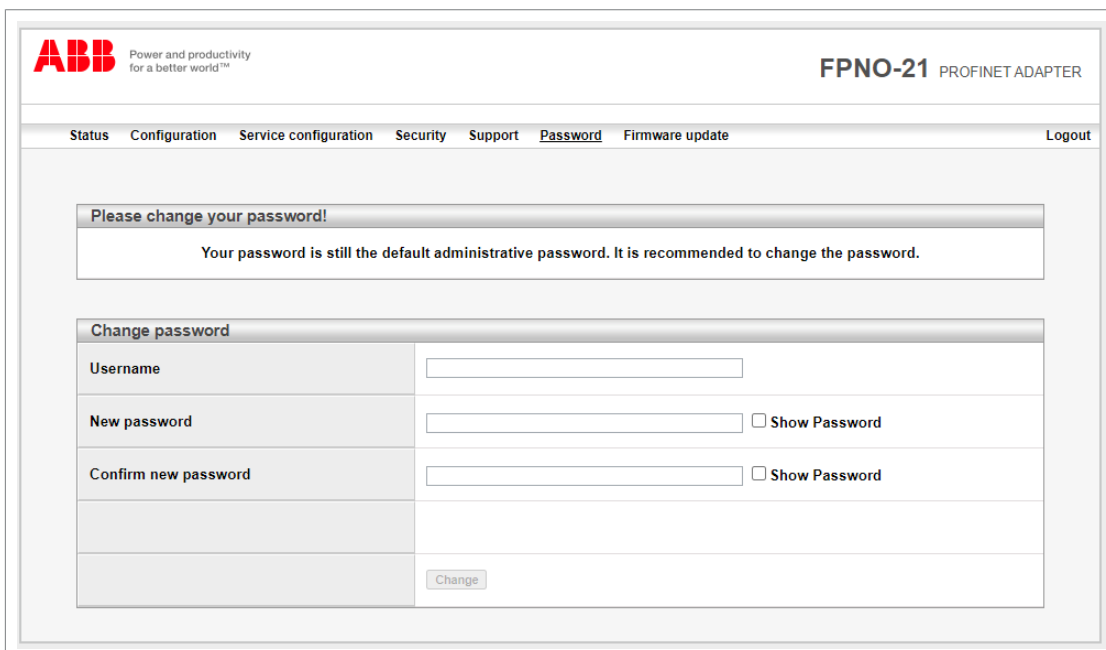

Menu overview

To navigate on the web pages, use the menu items available:

- Status
- Configuration
- Service configuration
- Security
- Support
- Password
- Firmware update

■ Status page

The Status page shows version information, as well as the serial number and MAC address (MAC ID) of the adapter module.

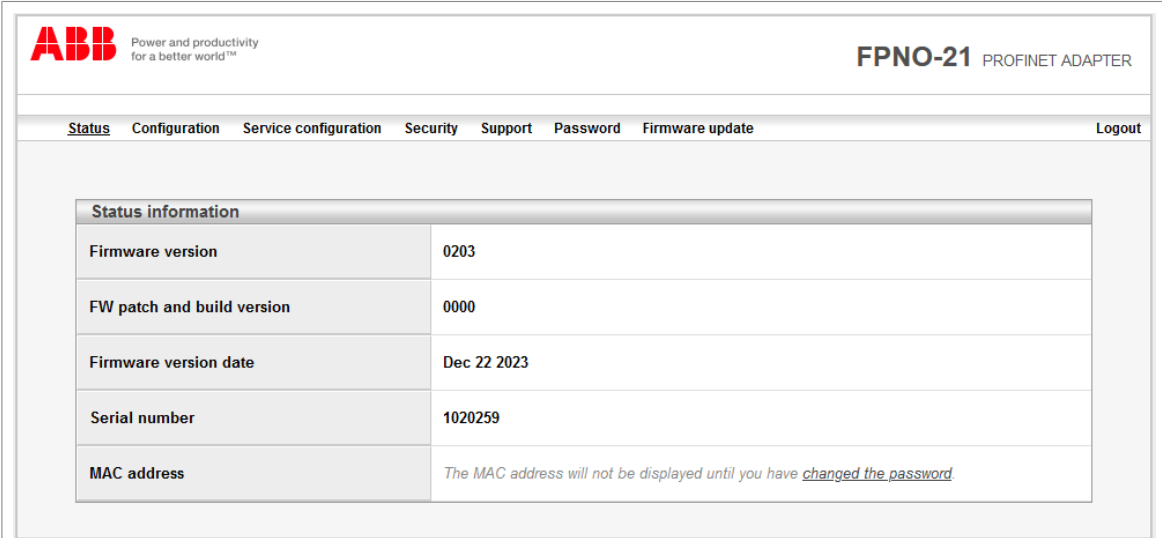

The screenshot shows the web interface for the FPNO-21 PROFINET ADAPTER. At the top left is the ABB logo with the tagline "Power and productivity for a better world™". At the top right, the device name "FPNO-21 PROFINET ADAPTER" is displayed. Below the header is a navigation menu with the following items: [Status](#), [Configuration](#), [Service configuration](#), [Security](#), [Support](#), [Password](#), [Firmware update](#), and [Logout](#). The main content area features a "Status information" table with the following data:

Status information	
Firmware version	0203
FW patch and build version	0000
Firmware version date	Dec 22 2023
Serial number	1020259
MAC address	<i>The MAC address will not be displayed until you have changed the password.</i>

■ Configuration page

On the Configuration page, you can modify parameter settings in the configuration parameter groups A (1), B (2) and C (3).



Power and productivity
for a better world™

FPNO-21 PROFINET ADAPTER

Status
Configuration
Service configuration
Security
Support
Password
Firmware update
Logout

Configuration parameters - Group A

Module information

51.01 Fieldbus adapter type	PROFINET
-----------------------------	----------

Ethernet configuration

51.02 Protocol/Profile	PROFINET IO, ABB Drives Profile (11) ▾
51.03 Communication rate	Auto-negotiate (0) ▾
51.04 IP configuration	Static IP (0) ▾
51.05-08 IP address	<input type="text" value="192.168.0.100"/>
51.09 Subnet mask	255.255.255.0 (24) ▾
51.10-13 Gateway address	<input type="text" value="0.0.0.0"/>
51.14 Communication rate for Port 2	Auto-negotiate (0) ▾
51.19 Transparent16 scale	<input type="text" value="99"/>

PROFINET IO configuration

51.16 Module emulation	Disabled (0) ▾
51.20 PROFINET IO Telegram type	<input type="text" value="8"/>
51.21 PROFINET IO Alarm sending	Enabled (0) ▾
51.22 PROFINET IO Map selection	16bit (1) ▾
51.25 PROFINET IO Name Index	<input type="text" value="1"/>
PROFINET IO Station Name	<input type="text" value="abbdribe-1"/>

Configuration parameters - Group B	
DATA OUT mapping (client to drive)	
53.01 Data out 1	<input type="text" value="47.12[32]"/>
53.02 Data out 2	<input type="text" value="0"/>
53.03 Data out 3	<input type="text" value="0"/>
53.04 Data out 4	<input type="text" value="0"/>
53.05 Data out 5	<input type="text" value="0"/>
53.06 Data out 6	<input type="text" value="0"/>
53.07 Data out 7	<input type="text" value="0"/>
53.08 Data out 8	<input type="text" value="0"/>
53.09 Data out 9	<input type="text" value="0"/>
53.10 Data out 10	<input type="text" value="0"/>
53.11 Data out 11	<input type="text" value="0"/>
53.12 Data out 12	<input type="text" value="0"/>

Configuration parameters - Group C	
DATA IN mapping (drive to client)	
52.01 Data in 1	<input type="text" value="47.11[32]"/>
52.02 Data in 2	<input type="text" value="0"/>
52.03 Data in 3	<input type="text" value="0"/>
52.04 Data in 4	<input type="text" value="0"/>
52.05 Data in 5	<input type="text" value="0"/>
52.06 Data in 6	<input type="text" value="0"/>
52.07 Data in 7	<input type="text" value="0"/>
52.08 Data in 8	<input type="text" value="0"/>
52.09 Data in 9	<input type="text" value="0"/>
52.10 Data in 10	<input type="text" value="0"/>
52.11 Data in 11	<input type="text" value="0"/>
52.12 Data in 12	<input type="text" value="0"/>

After you change any setting in any of the groups, click **Save** and reboot at the bottom of Group A to validate the settings.

Changing the PROFINET IO station name via web page

The PROFINET IO configuration web page is shown below with default values. The PROFINET IO Station Name field is blank by default.

PROFINET IO configuration	
51.20 PROFINET IO Telegram type	<input type="text" value="1"/>
51.21 PROFINET IO Alarm sending	<input type="text" value="Enabled (0)"/>
51.22 PROFINET IO Map selection	<input type="text" value="32bit (0)"/>
51.25 PROFINET IO Name Index	<input type="text" value="0"/>
51.PROFINET IO Station Name	<input type="text"/>

To set a new name, type the name in the PROFINET IO Station Name field. Click Save without rebooting, and then click Save and reboot to reboot FPNO-21. Refer to the screen on the Configuration page. The new name is effective only after FPNO-21 reboot.

Note: The value in PROFINET IO Name Index field must be 0 to use the set station name. Otherwise the name generated by the PROFINET IO Name index overrides it.

Example: PROFINET IO Station Name is set as fpno-21.

After you click Save without rebooting, and then click Save and reboot, the refreshed web page is as shown.

PROFINET IO configuration	
51.20 PROFINET IO Telegram type	<input type="text" value="1"/>
51.21 PROFINET IO Alarm sending	<input type="text" value="Enabled (0)"/>
51.22 PROFINET IO Map selection	<input type="text" value="32bit (0)"/>
51.25 PROFINET IO Name Index	<input type="text" value="0"/>
51.PROFINET IO Station Name	<input type="text" value="fpno-21"/> <i>changed</i>

The web page validates the Station name format and displays any correction to the new name, as in this example screen.

PROFINET IO configuration	
51.20 PROFINET IO Telegram type	<input type="text" value="1"/>
51.21 PROFINET IO Alarm sending	Enabled (0) <input type="button" value="v"/>
51.22 PROFINET IO Map selection	32bit (0) <input type="button" value="v"/>
51.25 PROFINET IO Name Index	<input type="text" value="0"/>
51.PROFINET IO Station Name	192.168.1.10 <i>Profinet name can't be in same format as an IP address.</i>
<input type="button" value="Save and reboot"/> <input type="button" value="Save without rebooting"/>	

If PROFINET IO Name Index was set from web page or from parameters, the PROFINET IO Station Name field shows its generated name after reboot, as in this example screen.

PROFINET IO configuration	
51.20 PROFINET IO Telegram type	<input type="text" value="1"/>
51.21 PROFINET IO Alarm sending	Enabled (0) <input type="button" value="v"/>
51.22 PROFINET IO Map selection	32bit (0) <input type="button" value="v"/>
51.25 PROFINET IO Name Index	<input type="text" value="123"/>
51.PROFINET IO Station Name	abbdrive-123
<input type="button" value="Save and reboot"/> <input type="button" value="Save without rebooting"/>	

■ Service configuration page

On the Service configuration page, you can enable or disable certain Ethernet services. All services except Simple Network Time Protocol (SNTP) and OPC UA server are enabled by default. You can disable or enable the following services on this page:

- access to FPNO-21 configuration web page
- allow to change IP settings remotely via ABB IP configuration tool
- remote access drive with Drive composer tool via Ethernet tool network
- Ping response
- web-based firmware update
- OPC UA server
- configure SNTP
- Simple Network Management Protocol (SNMP).

You can use SNMP to collect and organize information of the managed devices on IP networks.

The new settings take effect after reboot of the module. You can click Save and reboot, to validate the new settings immediately or click Save without rebooting if you want to do other settings also and then reboot.

The screenshot displays the configuration web interface for the FPNO-21 PROFINET ADAPTER. The interface includes a navigation menu with options: Status, Configuration, Service configuration (selected), Security, Support, Password, Firmware update, and Logout. The main content area is divided into three sections:

- Ethernet service configuration (saved settings will be in use after reboot)**: A table with 10 rows, each containing a configuration item and a dropdown menu.

FPNO configuration web pages	Enabled
Lock configuration	Disabled
ABB IP Configuration tool	Enabled
ABB Drive composer tool	Enabled
Unsecured ABB Drive composer tool	Disabled
Ping response	Enabled
Web-based firmware update	Enabled
OPC UA Server	Enabled
OPC UA Server unsecured	Disabled
- Simple Network Time Protocol (SNTP) configuration (saved settings will be in use after reboot)**: A table with 5 rows, each containing a configuration item and a text input field.

SNTP protocol	Disabled
SNTP update interval (seconds)	60
SNTP time offset to UTC (minutes)	0
SNTP Server address 1	
SNTP Server address 2	
- Simple Network Management Protocol (SNMP) configuration (saved settings will be in use after reboot)**: A table with 1 row, containing a configuration item and a dropdown menu.

SNMP protocol	Enabled
---------------	---------

At the bottom right of the configuration area, there are two buttons: "Save and reboot" and "Save without rebooting".

Note: These settings are available only through web pages. When you select to disable the web page, a warning appears to confirm before you can save the selection.

To enable the web page again, refer to [Enable web page access if it is disabled \(page 167\)](#).

ABB recommends that you disable all services that are not used after commissioning.

Configuring SNTP

You can use the Simple Network Time Protocol (SNTP) to synchronize drive time with a network time server. When SNTP is enabled, FPNO-21 requests the time from the configured server at a given interval. To receive this time synchronization, set parameter 96.20 Time sync primary source to **Fieldbus A**. The table shows the settings for SNTP:

Settings	Description	Value
SNTP update interval	Interval to request time from server.	Default: 30 seconds Minimum: 30 seconds
SNTP time offset to UTC	Time offset to the time received from SNTP. This value can also be set over PROFIdrive parameter 1001. Note: SNTP time offset change does not need a reboot.	-1440...1440 minutes
SNTP server address 1	Primary server address for requesting time. Format: IP address followed by optional port number, eg: 192.168.0.1:123 Note: If port number is missing, the default NTP port number "123" is used.	-
SNTP server address 2	Secondary server address used if the request to server 1 fails.	-

■ Security page

On the Security page, you can upload a private key and certificates for FPNO-21 to use instead of the self-signed certificate that FPNO-21 uses as a default. You can upload and manage Drive Composer certificate files on Security page under "Drive Composer certificate settings". Up to four certificates are supported at a time.

FPNO-21 uses secure HTTPS (TLS 1.2) communication for the web page server. By default, FPNO-21 does not require client authentication for the PC tool communication. You can use client authentication to improve the system security.

If unsecured communication is required, you can enable it from Service configuration page or by setting bit 4 of parameter 51.15 Service configuration. When unsecured communication is enabled, the PC tool communication is not encrypted or authenticated.

For more details, refer to [Drive Composer start-up and maintenance PC tool user's manual \(3AUA0000094606 \[English\]\)](#).

Note: Secure PC tool communication is possible with Drive Composer Pro version 2.7 or later.

The screenshot shows the 'Security' configuration page for the FPNO-21 PROFINET ADAPTER. The page has a navigation menu with 'Status', 'Configuration', 'Service configuration', 'Security', 'Support', 'Password', and 'Logout'. The 'Security' section is active.

Server certificate settings

Server certificate file for uploading	<input type="button" value="Choose File"/> No file chosen
Server private key file for uploading	<input type="button" value="Choose File"/> No file chosen
	<input type="button" value="Submit certificate and key"/> <input type="button" value="Remove certificate and key"/>
User uploaded certificate	None

Drive Composer certificate settings

[+] Certificate 1
[+] Certificate 2
[+] Certificate 3
[+] Certificate 4

■ Support page

On the Support page, you can access documentation related to the adapter module and the GSDML file.

The latest files corresponding to the drive firmware are available through the hyperlinks listed under "WWW documentation and downloads". You can find more information about each parameter under "Click here for more information about fieldbus parameters".

The screenshot shows the 'Support' page for the FPNO-21 PROFINET ADAPTER. The page has a navigation menu with 'Status', 'Configuration', 'Service configuration', 'Security', 'Support', 'Password', 'Firmware update', and 'Logout'. The 'Support' section is active.

[Click here for more information about Profinet adapter parameters.](#)

GSDML file

Local PROFINET GSDML file	GSDML File
---------------------------	----------------------------

WWW documentation and downloads

Fieldbus connectivity web page:	Fieldbus communications
FPNO-21 web page:	FPNO-21 Profinet adapter

■ Password page



WARNING! ABB recommends that you change the password and username as soon as possible.

On the Password page, you can change your password and username.

FPNO-21 supports only one user access level.

The password must contain:

- 6 to 20 characters
- at least 1 uppercase letter
- at least 1 lowercase letter
- at least 1 number
- at least one of the permitted special characters: !@#\$%^&*[]<>{}_-

The username must contain:

- 5 to 20 characters
- no special characters or spaces (only uppercase letters, lowercase letters and numbers are allowed).

Power and productivity
for a better world™

FPNO-21 PROFINET ADAPTER

Status
Configuration
Service configuration
Security
Support
Password
Firmware update
Logout

Change password

Username	<input style="width: 90%;" type="text"/>
New password	<input style="width: 90%;" type="password"/> <input type="checkbox"/> Show Password
Confirm new password	<input style="width: 90%;" type="password"/> <input type="checkbox"/> Show Password
<input type="button" value="Change"/>	

Change username

Current username	<input style="width: 90%;" type="text"/>
Current password	<input style="width: 90%;" type="password"/> <input type="checkbox"/> Show Password
New username	<input style="width: 90%;" type="text"/>
Confirm new username	<input style="width: 90%;" type="text"/>
<input type="button" value="Change"/>	

■ Firmware update page

On the Firmware update page, you can view the current firmware version of the adapter module and update the firmware. The firmware update requires adapter restart, so you cannot start the firmware update if the drive is currently controlled by the fieldbus adapter. All Ethernet communication to the drive (including PROFINET, Drive composer and OPC UA) will be lost during the firmware update.



WARNING! ABB recommends that you update the FPNO-21 module only when the drive is in local mode and not operational.

To update the adapter firmware, first upload the firmware loading package*:

- Click Browse.
- Select the correct firmware loading package (.lpe).
- Click Submit.

After uploading the firmware loading package, click Update to start the firmware update. The adapter restarts to complete the firmware installation.

*For the firmware loading package, contact ABB.

Power and productivity
for a better world™

FPNO-21 PROFINET ADAPTER

Status
Configuration
Service configuration
Security
Support
Password
Firmware update
Logout

Fieldbus adapter loading package

Select loading package for uploading	<input type="button" value="Browse..."/> No file selected. <input type="button" value="Submit"/>
User uploaded loading package	<p style="margin: 0;">No firmware loading package found. Upload the firmware loading package to the adapter.</p> <input type="button" value="Update"/> <input type="button" value="Remove"/>

Current firmware version information

Firmware version	0203
FW patch and build version	0000
Firmware version date	Dec 22 2023

Reset FPNO-21 web page password to default

You can reset the FPNO-21 web page password to factory default.

Note: The password can be reset only with local access to the drive.

1. Disconnect all cable connections to FPNO-21.
The NET led should switch off.
2. Write 0 (zero) to the parameter 26 under Group A (for example, 51.26).
3. Refresh the settings by selecting Refresh in parameter 27 (for example, 51.27).
4. Write 17989 to parameter 26 under Group A.
5. Refresh the settings by selecting Refresh in parameter 27.
6. Write 20033 to parameter 26 under Group A.
7. Refresh the settings by selecting Refresh in parameter 27.
8. Write 0 to parameter 26 under Group A.

FPNO-21 password is now reset to the default password. For information of default password, refer to [Logging in \(page 155\)](#).

Enable web page access if it is disabled

You can enable the access to web pages with drive parameters.

1. Disconnect all cable connections to FPNO-21.
The NET led should switch off.
2. Write 0 (zero) to the parameter 26 under Group A (for example, 51.26).
3. Refresh the settings by selecting Refresh in parameter 27 (for example, 51.27).
4. Write 87 to parameter 26 under Group A.
5. Refresh the settings by selecting Refresh in parameter 27.
6. Write 17730 to parameter 26 under Group A.
7. Refresh the settings by selecting Refresh in parameter 27.
8. Write 0 to parameter 26 under Group A.

Access to web pages is now enabled.

16

Appendix D - FPNO-21 configuration back-up

Contents of this chapter

This chapter presents the settings for FPNO-21 configuration backup.

Compatibility

FPNO-21 settings are stored in the drive parameters and also in the configuration files. FPNO-21 adapter module supports backup of all settings to the drive. These settings are now also included in any backups made of the drive using the Drive composer PC tool or the control panel.

Settings for backup

Consider these points:

- Backup is not slot-specific. For example, backup of FPNO-21 in FBA A, slot 1 can be restored to FPNO-21 FBA A, slot 2.
- Backup depends on the fieldbus channel. For example, backup of FPNO-21 in FBA A is not restored to FPNO-21 in FBA B.
- FPNO-21 configuration parameters are included in the backup when drive parameters are saved.

■ Configuration backup for all protocols in FPNO-21

Backup includes the following configuration for PROFINET IO in FPNO-21:

Configuration	Description
Ethernet service configuration	Enables different Ethernet services. Refer to Service configuration page (page 161) . When set, backup automatically includes this configuration.
Web page password	Login password for accessing FPNO-21 configuration web pages. Refer to Password page . Backup will automatically include the set password. Note: Backup includes the default password.
SNTP configuration	Enables SNTP, request interval, UTC offset, and server addresses. Refer to Service configuration page (page 161) . When set, backup will automatically include this configuration.
Station name	Sets the station name using DCP. Refer to PROFINET network settings (page 100) . When set, backup will automatically include this configuration.
I&M 1-3	Writable strings for identification and maintenance. Refer to I&M records (page 148) . When set, backup will automatically include this configuration.
PROFIdrive parameters 933-937 and 939-943	PROFIdrive CW and SW user bit mapping. Refer to PROFIdrive parameters (page 141) . Note: Backup will include this configuration only when it is stored with PROFIdrive parameter 971.
System location	Writable SNMP MIB-2 string. When set, backup will automatically include this configuration.
System name	
System contact	

The settings are saved to the drive after 10 seconds. If a Refresh command is given to FPNO-21 using parameter 51.27, the pending backup is transferred to drive immediately and FPNO-21 is rebooted after the transfer is completed.

Note: The new setting is not saved to drive if the drive was powered off or the adapter was disconnected from the drive within 10 seconds of changing a setting.

■ Using the restored backup

The use cases in the below table show how FPNO-21 settings are used after you restored a backup or after you powered up or enabled the module. The matching status box colours indicate matching configurations.

No.	Configuration status	
	Before restore	After restore
1	Restoring a backup to drive with Drive composer or panel.	
	<p>Drive with any configuration FB adapter with any configuration → Drive with configuration from backup → FB with configuration from backup</p>	
	Drive and fieldbus adapter can have any configuration.	Configuration from backup is used in drive and in FPNO-21
2	Replacing a new fieldbus adapter of the same type.	
	<p>Drive with backup FB adapter with no configuration → Drive with backup → FB with configuration from drive backup</p>	
	Drive has a backup of FPNO-21 configuration and a new FPNO-21 with no configuration is installed.	Drive backup is used in FPNO-21.
3	Replacing a fieldbus adapter with another adapter of the same type. But the new adapter was used with some other drive previously.	
	<p>Drive with backup FB adapter with previous configuration → Drive with backup → FB with configuration from drive backup</p>	
	Drive has a backup of FPNO-21 configuration and a new FPNO-21 with existing configuration is attached.	Drive backup is used in FPNO-21.
4	A new drive and fieldbus adapter are used.	
	<p>Drive with no backup or backup of another FB adapter FB adapter with default configuration → Drive with new backup from FB ← FB with default configuration</p>	
	Drive has no backup or a backup of some other type of fieldbus adapter other than FPNO-21 exists. FPNO-21 with no configuration is attached.	FPNO-21 generates a new backup with its default settings and copies it to drive.

No.	Configuration status	
	Before restore	After restore
5	Replacing drive with a new drive and reusing the old Fieldbus adapter.	
	Drive has no backup or a backup of some other type of fieldbus adapter other than FPNO-21 exists. FPNO-21 with an existing configuration is attached.	FPNO-21 copies its backup to drive.
6	Clearing fieldbus configuration from drive and module to defaults.	
	You can clear the fieldbus configuration from drive and module to defaults with parameter 96.06 Parameter restore using the selection Reset all fieldbus settings.	Clears the fieldbus parameters and backup files for FBA A and FBA B on the drive side. If a FPNO-21 module is connected, its configurations are reset to defaults.

A large, bold, black number '17' is centered within a light gray square with rounded corners.

Appendix E - OPC UA server

Contents of this chapter

This chapter provides instructions on how to enable, configure, and use the OPC UA server and client.

OPC UA

OPC UA is a communication protocol for interoperability and data exchange between different devices, systems and applications. OPC UA stands for Open Platform Communications Unified Architecture, and it is based on open standards and technologies.

OPC UA provides a secure, reliable and scalable way to access data from drives and other sources. OPC UA supports different transport protocols, data formats and encryption methods. OPC UA supports strong authentication methods that differentiate the client and user with fine granular role-based access rights.

With OPC UA, users can access real-time and historical data and events from drives, such as speed, torque, current, voltage, temperature, alarms, faults and diagnostic codes. OPC UA allows users to create custom views and dashboards of the drive data, as well as to integrate the drive data with other systems and applications, such as SCADA, HMI, MES, ERP and cloud services. OPC UA enables data collection parallel to various protocols and networks, such as PROFINET.

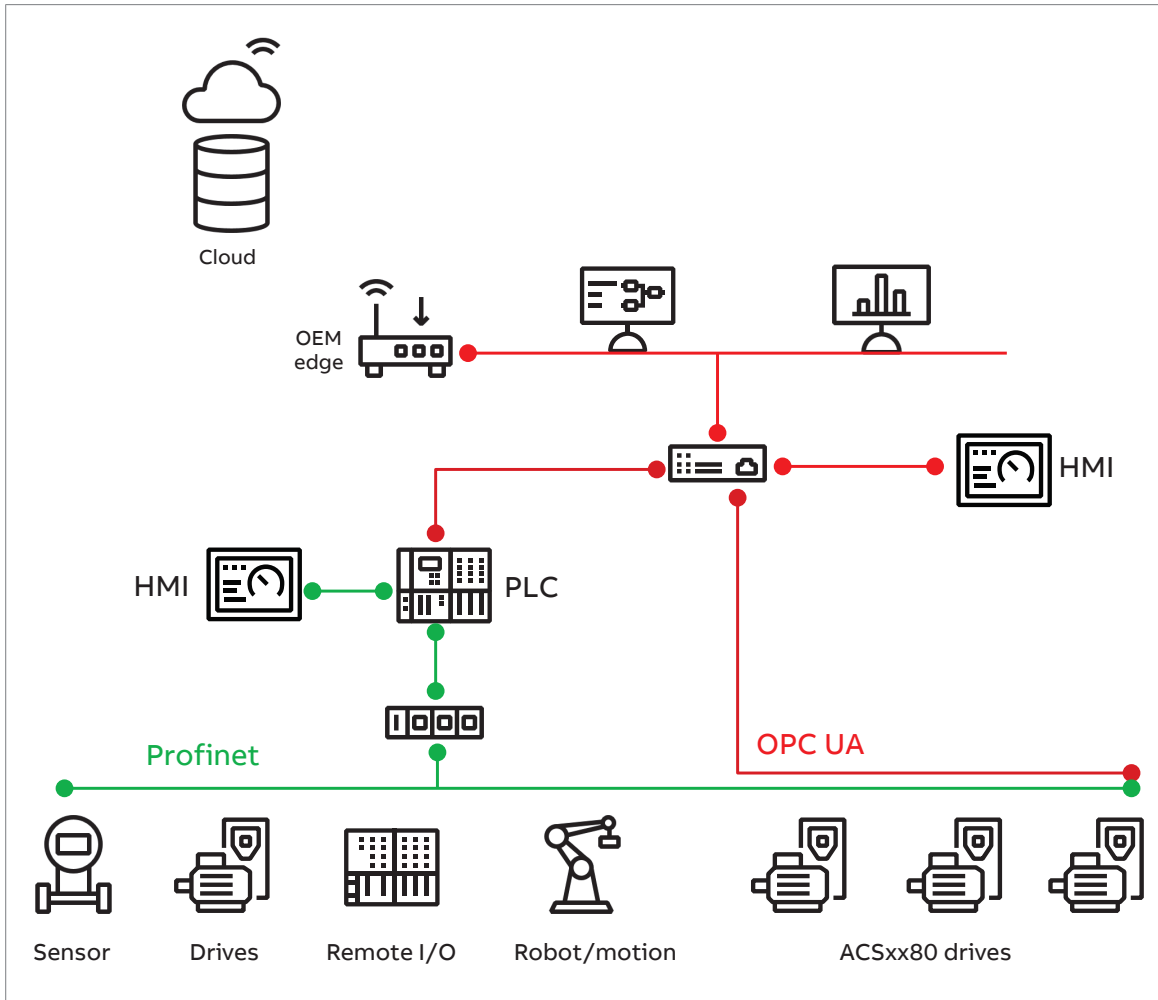

Compatibility

OPC UA server enables ABB drives to operate with any OPC UA compliant client. OPC UA requires FPNO-21 version 2.03 or later.

Supported drives:

- ACS880
- ACS580
- ACH580
- ACQ580
- ACS480
- ACH480
- ACS380

Supported services and features

The OPC UA server supports these OPC UA services and features:

- Read and write service: Read and write OPC UA node data.
- Browse service: Examine the OPC UA server address space and read the OPC UA nodes and their attributes.

- Supported endpoints: For secure and encrypted communication between the OPC UA server and the client. Support for None, Sign and Sign & Encrypt security modes. Support for None, Basic128RSA15 and Basic 256 security policies. For more information, refer to [Encrypted Communication](#).
- Subscription and monitored item service: Subscribe to OPC UA node data and notifications when the data changes.
- Event service: Subscribe to Drives events, warnings, faults and receiving notifications when events occur. Historical event access is available.
- Information model: OPC UA Device Integration (DI) information model for asset and actual value monitoring. OPC UA FX (Field eXchange) information model to represent assets information for drives, motors and interface adapters.
- Anonymous user authentication modes
- Accessible to multiple OPC UA clients at the same time.

Enabling OPC UA server on an ABB drive

The OPC UA server on the ABB drive is not enabled by default. You can enable the OPC UA server with parameter [15 Service configuration](#), bit 7.

Note: After you enable the OPC UA server for the first time or if the IP address changes, the OPC UA server creates a self-signed certificate. This can take up to 60 seconds.

Note: For the OPC UA timestamps to function properly, the drive time must be synchronized with the universal coordinated time (UTC). Set the drive time to UTC before establishing the OPC UA connection. You can use the drive control panel or drive composer tool to adjust the drive time. ABB recommends SNTP (Simple Network Time Protocol) server to synchronize the time of all drives to same source. Refer to [Configuring SNTP \(page 162\)](#).

■ Encrypted Communication

The OPC UA server supports encrypted communication with different security policies. The OPC UA server provides the following endpoints for encrypted communication:

- **None:** No encryption or signing. It is deactivated by default. Use this only for testing or in trusted networks. To enable it, refer to parameter [15 Service configuration](#), bit 8.



WARNING! ABB recommends that you do not use None in unprotected networks to reduce cyber security risks.

- **Sign with Basic256Sha256:** This endpoint uses SHA-256 as the hash algorithm and RSA as the signature algorithm with 256-bit keys. It signs the messages but does not encrypt them. It is deactivated by default. Use this only when encryption is not required or supported by the client. To enable it, refer to parameter [15 Service configuration](#), bit 8.
 - **SignAndEncrypt with Basic256Sha256:** This endpoint uses SHA-256 as the hash algorithm, RSA as the signature algorithm with 256-bit keys, and AES as the encryption algorithm with 256-bit keys. It signs and encrypts the messages. This is the recommended endpoint for most applications.
-

- **Sign with Aes128_Sha256_RsaOaep:** This endpoint uses SHA-256 as the hash algorithm, RSA with OAEP padding as the signature algorithm with 2048-bit keys, and AES as the encryption algorithm with 128-bit keys. It signs the messages but does not encrypt them. It is deactivated by default. Use this only when the client does not support Basic256Sha256. To enable it, refer to parameter [15 Service configuration](#), bit 8.
- **SignAndEncrypt with Aes128_Sha256_RsaOaep:** This endpoint uses SHA-256 as the hash algorithm, RSA with OAEP padding as the signature algorithm with 2048-bit keys, and AES as the encryption algorithm with 128-bit keys. It signs and encrypts the messages. This endpoint offers a higher level of security than Basic256Sha256. Use this endpoint when the client supports it.

To use an encrypted endpoint, the OPC UA client software must provide a valid certificate and trust the certificate of the OPC UA server. The certificates are used to authenticate the identity of the OPC UA server and the client and to exchange the encryption keys. The certificates can be self-signed or issued by a trusted authority. The OPC UA server and the client must also have the same security policy and security mode selected for the encrypted communication to work. The OPC UA client software can display the available endpoints of the OPC UA server and allow the user to choose the preferred one.

Note: Only a self-signed certificate is supported by FPNO-21 V2.03 OPC UA server.

OPC UA subscription

The OPC UA server supports up to 50 subscriptions. An OPC UA subscription lets an OPC UA client software get data changes and events from the OPC UA server. The OPC UA client sets the monitored items, the sampling interval, the publishing interval, and other parameters for the subscription. The publishing interval is the time between notification messages from the OPC UA server. The monitored items are the variables or events that the OPC UA client software wants to get updates on. Each monitored item has a sampling interval, which is the frequency with which the OPC UA server checks its value or status. The OPC UA server sends notification messages with the data changes or events to the OPC UA client software at the publishing interval. The OPC UA client software can create, modify, or delete subscriptions as needed.

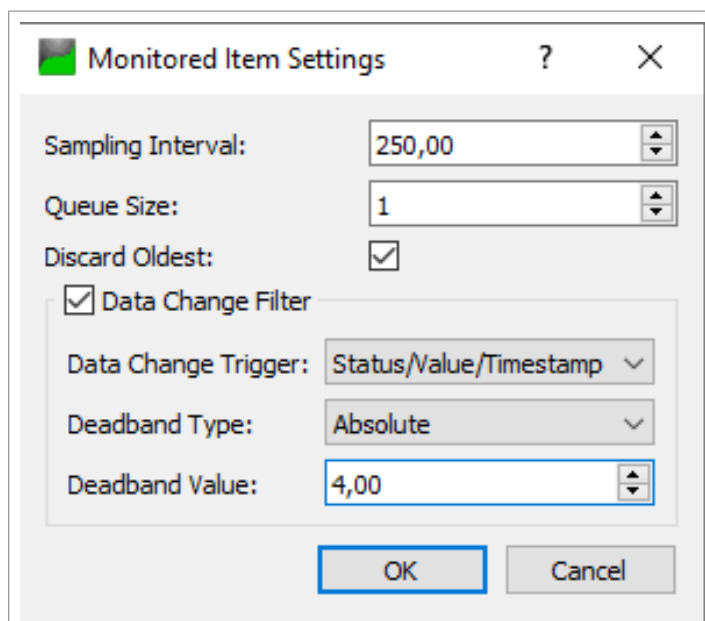

Accessing drive events and event log with OPC UA

The OPC UA server can send OPC UA Events to inform an OPC UA client about drive events, such as warnings and faults.

Drive events use specific event types derived from 1:DriveEventType.

Property BrowseName	Data type	Description												
EventId	NodeId	A unique identifier for the event. This identifier can be used to distinguish between different events.												
EventType	NodeId	Identifies the type of the event. It specifies the event type that is instantiated. The following event types are supported: <table border="1" data-bbox="820 689 1457 1128"> <thead> <tr> <th>EventType</th> <th>Description</th> </tr> </thead> <tbody> <tr> <td>1:DriveFaultEventType</td> <td>Generate on fault</td> </tr> <tr> <td>1:DriveWarningActiveEvent- Type</td> <td>Generate when warning activates</td> </tr> <tr> <td>1:DriveWarningCleare- dEventType</td> <td>Generate when warning is cleared</td> </tr> <tr> <td>1:DrivePureEventType</td> <td>Generate on general notific- ation</td> </tr> <tr> <td>1:DriveFaultResetEvent- Type</td> <td>Generate on fault reset</td> </tr> </tbody> </table>	EventType	Description	1:DriveFaultEventType	Generate on fault	1:DriveWarningActiveEvent- Type	Generate when warning activates	1:DriveWarningCleare- dEventType	Generate when warning is cleared	1:DrivePureEventType	Generate on general notific- ation	1:DriveFaultResetEvent- Type	Generate on fault reset
EventType	Description													
1:DriveFaultEventType	Generate on fault													
1:DriveWarningActiveEvent- Type	Generate when warning activates													
1:DriveWarningCleare- dEventType	Generate when warning is cleared													
1:DrivePureEventType	Generate on general notific- ation													
1:DriveFaultResetEvent- Type	Generate on fault reset													
SourceNode	NodeId	Node that caused the event. SourceNode is always "i=2253".												
Message	LocalizedText	A human-readable description of the event. It shows the drive event name including fault code and aux code in HEX format.												
Severity	UInt16	Represents the severity of the event. It provides an indication of the urgency or importance of the event. 50: Fault reset 100: Event 500: Warning 750: Fault												
SourceName	String	DisplayName of the object node (SourceNode) that caused the event. = "Server"												
Time	UtcTime	Indicates the time the event occurred. This is the time the event is generated.												
ReceiveTime	UtcTime	Indicates the time the server received the event over drive back end (option card interface)												
1:BasicCode	UInt16	The drive event code												
1:AuxCode	UInt32	Auxiliary code of the drive event code												

Note: ns=1: <http://www.abb.com/Motion>.

Example of the event notification:

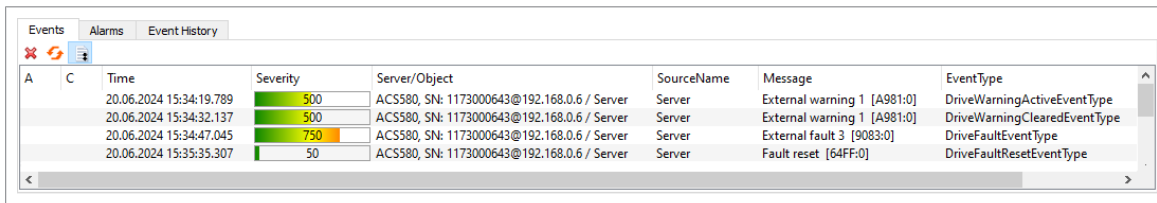

A	C	Time	Severity	Server/Object	SourceName	Message	EventType
		20.06.2024 15:34:19.789	500	ACS580, SN: 1173000643@192.168.0.6 / Server	Server	External warning 1 [A981:0]	DriveWarningActiveEventType
		20.06.2024 15:34:32.137	500	ACS580, SN: 1173000643@192.168.0.6 / Server	Server	External warning 1 [A981:0]	DriveWarningClearedEventType
		20.06.2024 15:34:47.045	750	ACS580, SN: 1173000643@192.168.0.6 / Server	Server	External fault 3 [9083:0]	DriveFaultEventType
		20.06.2024 15:35:35.307	50	ACS580, SN: 1173000643@192.168.0.6 / Server	Server	Fault reset [64FF:0]	DriveFaultResetEventType

Connection example

The OPC UA client software in this example is UaExpert v1.7. from Unified Automation GmbH. For more information, refer to

<https://www.unified-automation.com/products/development-tools/uaexpert.html>.

To connect the OPC UA client to an OPC UA server on an ABB drive:

1. Enable the OPC UA server with parameter [15 Service configuration](#), bit 7.
2. Start the OPC UA client software and open the project that was created or configured previously.
3. Discover the OPC UA server.
Enter the endpoint URL of the OPC UA server in the format "opc.tcp://<ip_address>:4840". The <ip_address> refers to the IP address of the Ethernet connection on the ABB drive. The default port number of the OPC UA server is 4840. Example: opc.tcp://192.168.21.210:4840.
Alternatively you can select the OPC UA server from the list of available servers and click Connect.
4. Select the security mode and the security policy for the OPC UA connection. The security mode can be none, sign, or sign and encrypt.
5. Select the Anonymous Authentication method.

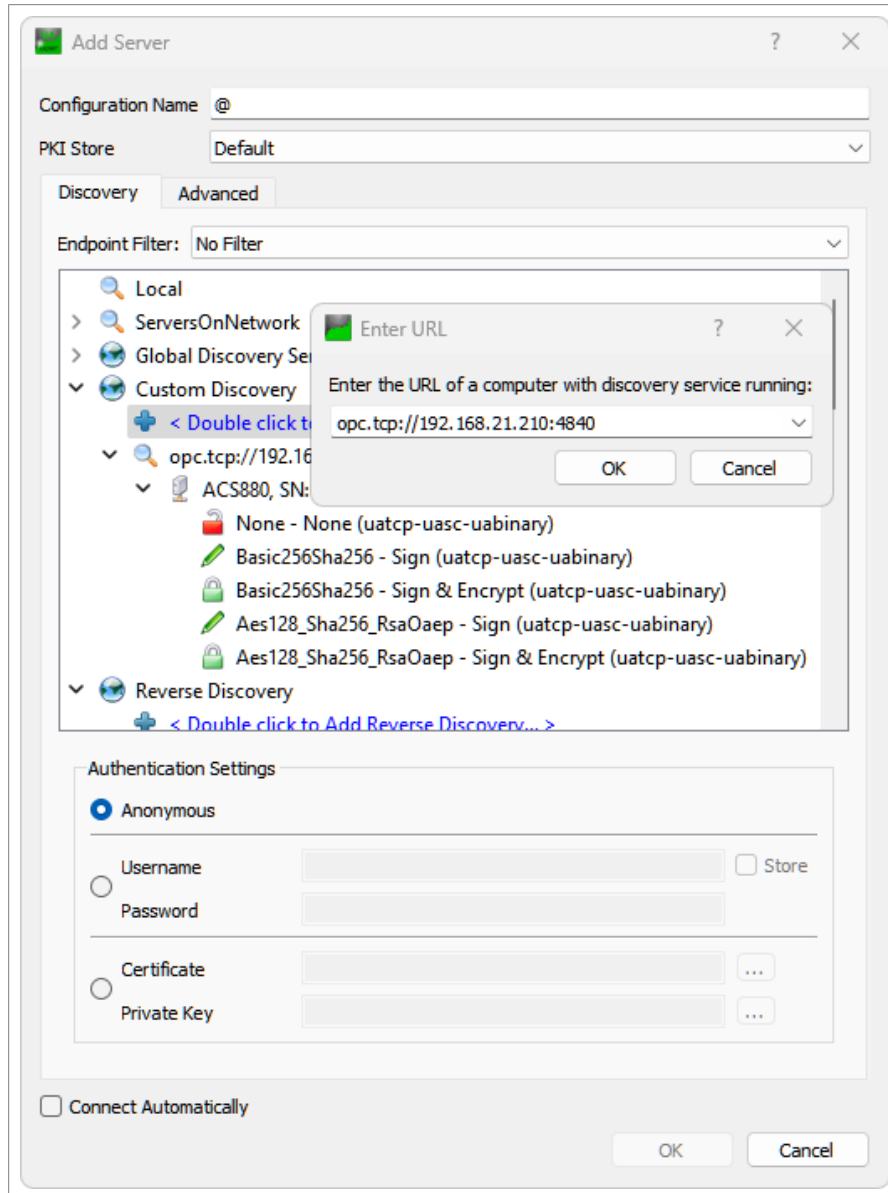

6. Accept the certificate of the OPC UA server.
7. Wait for the OPC UA connection to be established and verified. The OPC UA client software should show a message that the connection is successful and show the status and the details of the connection.

Example of the information model:

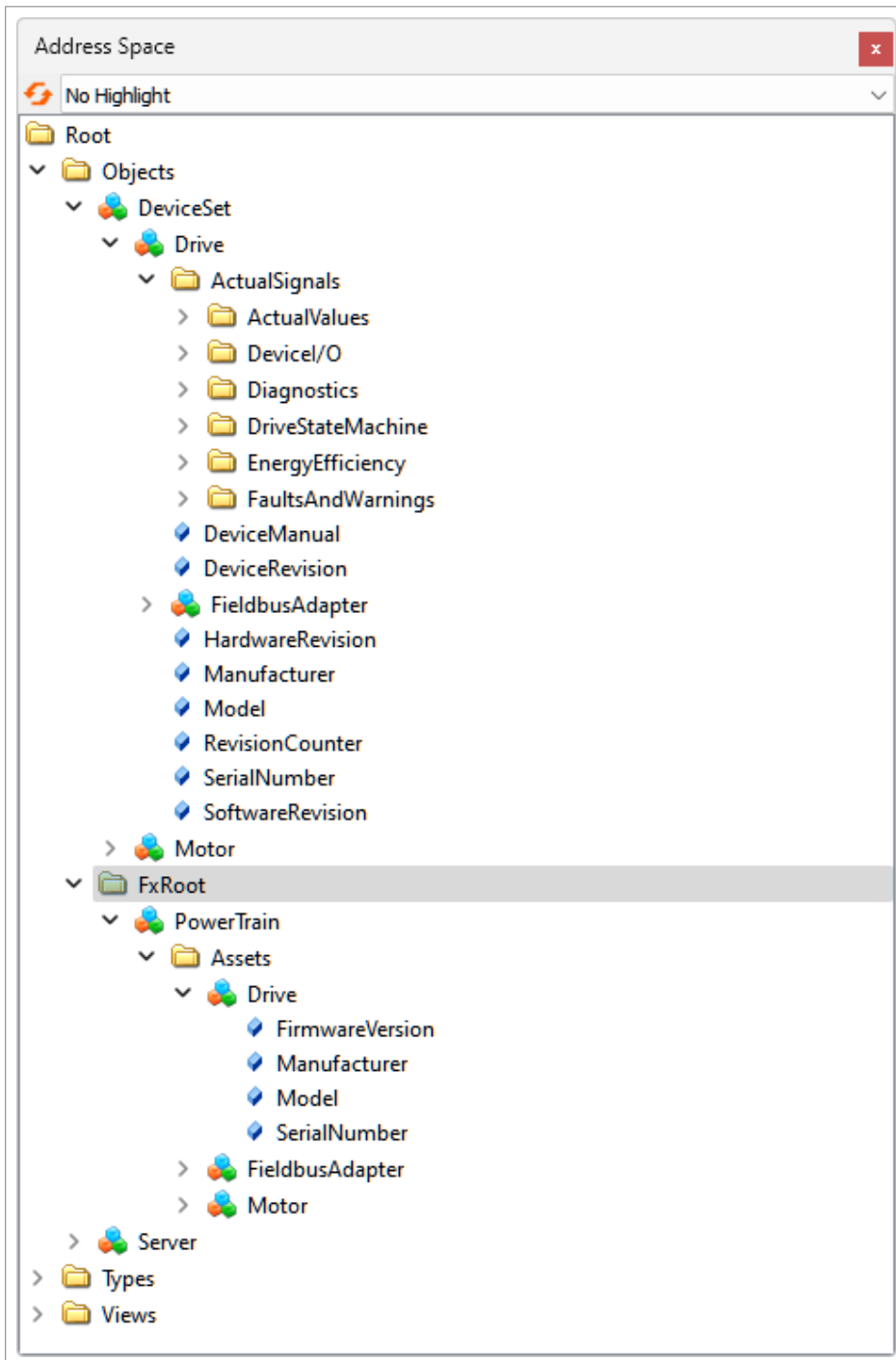

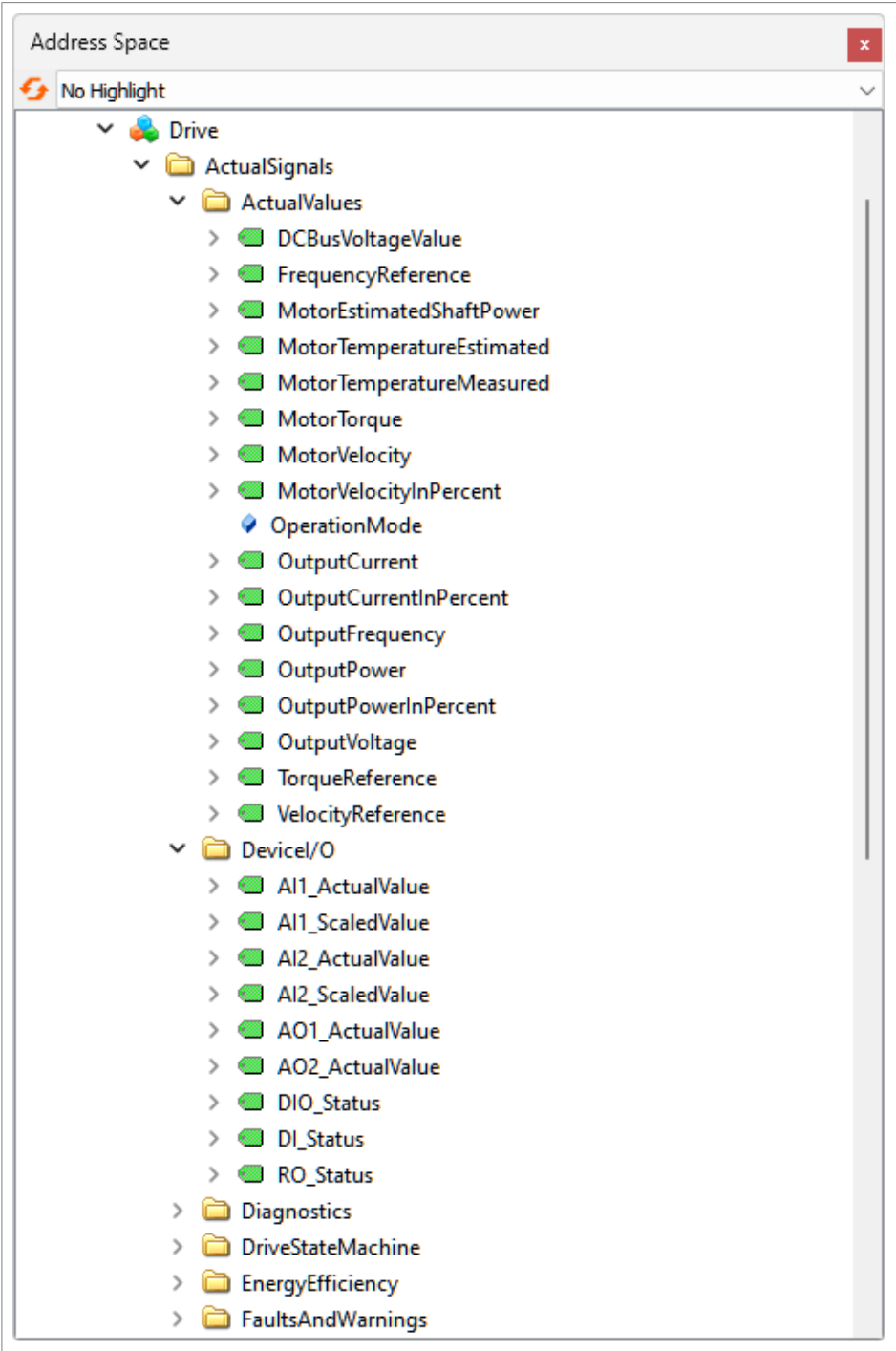

Technical data

The default OPC UA Application name is <Drive type>, SN: <drive serial number>. Example: ACS880, SN 1234567890.

The implementation of the OPC UA server is based on these specifications:

- OPC UA v1.05.02 (released 2022)
- OPC 10000-100, Device Model v1.04 (released 2022)
- OPC UA Field eXchange with:
 - OPC 10000-80, Overview and Concepts v1.00 (released 2022)
 - OPC 10000-81, Connecting Devices and Information Model v1.00.02 (released 2022)
- VDMA 40400-1: OPC UA for Powertrain
 - Part 1: Asset Management

Maximum number of connections	5
Maximum number of subscription	50
Maximum number of monitored items (over all clients)	50
Maximum monitored items per subscription	50
Minimum sample rate	100 ms



Further information

Product and service inquiries

Address any inquiries about the product to your local ABB representative, quoting the type designation and serial number of the unit in question. A listing of ABB sales, support and service contacts can be found by navigating to www.abb.com/contact-centers.

Product training

For information on ABB product training, navigate to new.abb.com/service/training.

Providing feedback on ABB manuals

Your comments on our manuals are welcome. Navigate to forms.abb.com/form-26567.

Document library on the Internet

You can find manuals and other product documents in PDF format on the Internet at www.abb.com/drives/documents.



www.abb.com/drives



3AXD50000158614C